

DESIGN DATA SHEET
DEPARTMENT OF THE NAVY, BUREAU OF SHIPS

DDS 9290-4
PASSIVE ANTI-ROLL TANKS*

1 September 1962

TABLE OF CONTENTS

	<u>Page</u>
References	2
Definitions and symbols	2
ARTICLE	
9290-4-a Introduction	3
9290-4-b Preliminary Design Procedure	4
1. Selection of design conditions	4
2. Tank geometry	4
3. Tank location	4
4. Tank liquid	4
9290-4-c Preparation for final design	5
9290-4-d Final design procedure	5
1. Calculation of ship properties (KG, GM, roll axis, roll period, moment to heel)	5
2. Calculation of tank properties (tank frequency, de-coupling or secondary resonance, tank moments)	6
3. Calculation of tank fluid weights	7
4. Calculation of tank moments	7
5. Nozzle design - general	7
6. Analysis of ship plus tank system (sea input, model testing, computer analysis)	8
7. Loss in GM due to tank free surface	8
9290-4-e Illustrative example 1	8
9290-4-f Illustrative example 2	11
9290-4-g Summary of equations	14

♦*The U.S. Government is licensed under U. S. Patent 3,054,373 to use patented structure for all Governmental purposes. ♦

Note: Symbol ♦ shows change to replaced page

Rev. 1 Nov. 1963

REFERENCES

- (a) "Theory of Naval Architecture" by A. M. Robb (1952), pages 306-322
- (b) "On the Dynamics of Anti-Rolling Tanks" by K. Klotter and J. H. Chadwick (English text published 1955 by C. Schroedter & Co., Hamburg)
- (c) "The Anti-Roll Stabilization of Ships by Means of Activated Tanks" by A. J. Morris and J. H. Chadwick (1951) - (Technical Report No. 15, Part B of work prepared under Contract N6-ONR-251 Task Order 2)
- (d) "Roll Stabilization by Means of Passive Tanks" by J. Vasta, A. J. Giddings, A. Taplin, and Capt. J. J. Stilwell, USN, Transactions of SNAME 1961

DEFINITIONS AND SYMBOLS

(NOTE: All linear dimensions are in feet unless otherwise noted)

A_n	=	"Sectional Area" of tank nozzles
R	=	$\frac{h}{B}$ A non-dimensional characteristic of tank geometry
b_n	=	Transverse distance between nozzles (see Fig. 1)
b_l	=	Transverse length of nozzle (see Fig. 1)
B	=	Transverse tank dimension (see Fig. 1)
$\frac{\ell_c}{\ell_t}$	=	A non-dimensional characteristic of tank geometry
C_n	=	$\frac{\ell_n}{B}$ A non-dimensional characteristic of nozzle spacing
C_w	=	$\frac{\ell_t}{B}$ A non-dimensional characteristic of tank geometry
d	=	A dimension of a nozzle (see Fig. 1)
g	=	Acceleration due to gravity, 32.17 ft/sec ²
ℓ_n	=	Spacing of nozzles (see Fig. 1)
K	=	Roll period coefficient
K_s	=	Ship moment to heel 1°
K_t	=	Tank static moment factor per degree list
K'_t	=	Dynamic tank moment factor
ℓ_t	=	Fore-and-aft extent of tank (see Fig. 1)
ℓ_c	=	Fore-and-aft extent of cross-over duct (see Fig. 1)

Definitions and symbols (Continued)

N	=	Number of nozzle clear openings
l_n	=	Nozzle spacing (see Fig. 1)
η_n	=	Nozzle clear opening (see Fig. 1)
r	=	Radius of nozzle (see Table I)
T	=	Ship period of roll (seconds), full cycle, i. e. port to starboard to port
Z_o	=	Vertical distance between bottom of tank and ship roll axis, as in Fig. 1
h	=	height (depth) of liquid in tank (see Fig. 1)
$\gamma = \frac{bn}{B}$	=	A non-dimensional characteristic of tank nozzle location
r_t	=	Tank dimensionless natural period
r_{st}	=	Secondary resonance dimensionless period
ω_s	=	Ship natural circular frequency = radians/sec.
ω_t	=	Tank natural circular frequency (radians/sec.)
W_a	=	Weight of "active" tank fluid
W_t	=	Total weight of tank fluid
Δ	=	Ship displacement (tons)
r_b, r_n	=	Components of r_t
SpecVol	=	Specific Volume, cubic feet per ton
dcf	=	dynamic correction factor

9290-4-a Introduction

Reduction of roll by means of passive tanks has been tried, on and off, for over 80 years. A description of some of the pioneer installations is contained in references (a) and (d). Most of the available literature is on the subject of U-shaped tanks. This design data sheet shows present design procedure for tanks which are approximately "H" shaped or rectan-

gular in plan view, and which have nozzles of a variety of shapes port and starboard, as in Fig. 1. The method is still somewhat empirical, since all the testing to determine the effects of simplifications and limitations in theory is not complete. The method here is an extension of the U-shaped tank theory, for which comprehensive technical discussion is available in references (a), (b), and (d). Before proceeding further, it should

be realized that the static or damaged stability of the ship will be reduced by the free surface in the tanks. Section 9290-4-d-7 provides a method of estimating this effect.

9290-4-b Preliminary Design Procedure

1. Selection of design conditions

Select a displacement and KG representative of a mid-voyage condition of the ship. If no other data are available, use a displacement about equal to the light ship plus 2/3 of the difference between light ship and full load. Calculate GM for this condition, ignoring any free surface effects due to the stabilizer tanks.

2. Tank geometry

(a) For a first approximation select a location for the tank which will provide nearly the full beam of the ship for the tank, which also provides at least one full deck height for the tank, and with the fore-and-aft extent of the tank, (l_t) to the nearest frame being approximately 18% of the tank width. Calculate the desired $(r_t)^2$ by the procedure in 9290-4-b-2-(d), and calculate the preliminary R assuming the compartment to be half filled with water. Enter these values on figure 2 to determine the approximate type of tank needed. If the intersection of R and $(r_t)^2$ falls near the top band, an H-shaped tank is indicated; if it falls in the lowest band a rectangular plan form tank is indicated; if it falls between, either type can be used, but the H type is preferred since it will be lighter in weight of fluid.

(b) Calculate the approximate weight of active liquid by the procedure given in 9290-4-d-3, using for this approximation, $\gamma = .6$ and depth of liquid equal to half the compart-

ment height. This should be between 1/2% and 1-1/4% of the ship displacement.

(c) Modify as necessary so that for a steady list of 1° the tank static moment is at least 12% of conventional moment to heel 1° . This involves computing K_t by the procedure in 9290-4-d-4-(a). For this first estimate, use $\gamma = .6$.

(d) Compute tank natural frequency (ω_t) by the procedure in 9290-4-d-(2) (except that for this preliminary calculation of $(r_t)^2$ assume $(r_t)^2 = (r_b)^2$ so that only the first term, $(r_b)^2$, is needed). Then revise tank geometry and water depth so that the tank natural frequency is between 100% and 110% of ship natural frequency (see 9290-4-d-1-(d)).

(e) Recalculate tank volume and static moment based on the shape developed in (d) above. Revise shape so that the tank moment is again at least 12% of the ship moment, using the developed tank shape. When faced with a choice between two tank configurations which meet the above criteria, a convenient guide to selection is to choose the design with the maximum "lever arm" which is the ratio; K_t divided by W_t . (See 9290-4-d-4-(a) and 3-(b).)

3. Tank location on ship

(a) Vertical. Tanks should be located as high as is compatible with other ship requirements. Effectiveness is affected by the "dynamic correction factor" and increases for tanks above the ship's center of gravity, and decreases for tanks below the ship's center of gravity. The correction factor is explained in 9290-4-d-2-(c).

(b) Fore-and-aft. The preferred fore-and-aft tank location is in the

amidships 3/5 portion. Although no calculation is made for variation in fore-and-aft location, the amidships location minimizes possible adverse effects from yaw and provides for maximum beam.

(c) Transverse. The tank should be as wide as possible, preferably extending from shell to shell.

4. Tank liquid

Diesel oil or water are suitable. Other liquids may be used provided viscosity does not significantly change the tank period. Stabilizer effectiveness is proportional to the liquid density.

9290-4-c Preparation for final design

1. After having gone through the above preliminary procedure, the approximate requirements are known in terms of internal volume and effects on arrangements. The quantitative calculation of roll reduction from theory (discussed more fully in references (a), (c), and (d)) is a complex operation which need not be carried out. For all practical purposes, the numerical ranges of parameters presented in this Design Data Sheet result in a practical installation having a significant roll reduction capacity.

2. The procedure in 9290-4-b results in an installation which will reduce average roll by roughly 50%. Considering this and the effect on ship arrangements, a decision is now made as to whether to install tanks of the size resulting from the preliminary design procedure, or whether a little more space and weight should be allocated to get more roll reduction.

9290-4-d Final design procedure

1. Calculation of ship properties.

(a) KG is computed as in standard calculations for the displacement condition selected.

(b) GM is the difference between the standard height of transverse metacenter above keel, KM, (assumed to remain fixed at angles of roll here considered), and the KG determined in the paragraph above. (GM = KM - KG) It is further corrected for free surface except that no free surface correction is made for the tank liquid.

(c) The roll axis is assumed to be fixed at the KG determined above, or at an experimentally determined location.

(d) The roll period of the ship is computed by the standard formula

$$T = \frac{(K) (\text{Ship beam})}{\sqrt{GM}} \quad (1)$$

where T is the period of a complete cycle (seconds), K is an empirical coefficient (usually ranging from .38 to .44), related to the effective ship radius of gyration. Values of K are obtained, in order of preference, from at sea records of roll, from sallying, or from similar ships. The ship beam is in feet, and GM is as calculated in 9290-4-d-1-(b). The corresponding roll circular frequency is $\frac{2\pi}{T}$ radians per second, and is designated as ω_s . The corresponding "non-dimensional period" is defined by;

$$(r_s)^2 = \frac{g}{2\pi^2} \left(\frac{T^2}{B} \right) = 1.63 \left(\frac{T^2}{B} \right)$$

or, the equivalent,

$$r_s^2 = \frac{2g}{B\omega_s^2} \quad (2)$$

This dimensionless form is used since it is convenient to the calculation of tank properties. In order to have the desired ratio of tank natural frequency to ship natural frequency of 1.1, the desired tank dimensionless period should be

$$(\tau_t)^2 = 0.826 (\tau_s)^2 \quad (3)$$

(e) Moment to heel the ship 1° is calculated from the standard formula:

$$\begin{aligned} K_s &= \text{Mom. to heel } 1^\circ \\ &= (.0175) \Delta \quad (\text{GM}) \\ &\quad (\text{ft-tons}) \end{aligned} \quad (4)$$

2. Calculation of tank properties.

(a) Calculations are required for the tank natural circular frequency and for the decoupling or secondary resonance circular frequency ω_{st} . Model tests conducted to date indicate that frequency calculations for the tanks described herein can be treated by analogy to U-tube tanks. Referring to Fig. 1, the "H" shaped volume of tank liquid without "nozzles" has the dimensions h by l_t and l_c by B . The nozzle arrangement has the significant dimensions l_n, η_n, b_n , sectional area A_n , and number of openings, N . The ratio $\frac{N\eta_n}{l_c}$, or "choke" ratio should be approximately 0.4 ($2 - l_c/l_c$). A $\pm 10\%$ variation from this is acceptable.

(b) The tank dimensionless period and natural frequency are derived from geometry alone, and are

computed as though the tanks were a U-tube filament. The tank dimensionless period is divided in two parts, the "basic" period " τ_b " and the "nozzle contribution," " τ_n ", so that

$$(\tau_t)^2 = (\tau_b)^2 + (\tau_n)^2 \quad (5)$$

where

$$(\tau_b)^2 = \mathcal{R} + \frac{M}{\mathcal{R}} \quad (6)$$

$$(\tau_n)^2 = \frac{2Aob_n}{hB l_c} \left[\frac{l_c F}{N\eta_n} - 1 \right] \quad (7)$$

where

M is as shown on Figure 3, a function of γ and $\frac{l_c}{l_t}$.

A_o is the free surface area of one wing tank and is equal to

$(B - b_n) \frac{l_t}{2}$ less nozzle deduction if the shape so warrants

F is as shown on figure 4, a function of $\frac{\eta_n}{l_n}$ and nozzle sectional area ratio.

From this, the desired

$$\omega_t = \sqrt{\frac{2g}{B (\tau_t)^2}} \quad (8)$$

Table 1 shows area ratios for several nozzle shapes. Nozzle area ratio is analogous to a waterplane coefficient and is illustrated in Figure 5.

(c) Next the secondary resonance dimensionless period τ_{st} is obtained from the following expression:

$$(\tau_{st})^2 = \pm 2 \frac{Z_o}{B} \quad (9)$$

where the plus sign is to be used if the bottom of the tank is below the roll axis, and the minus sign is used if the bottom of the tank is above the roll axis. From $(r_{st})^2$, the secondary resonance frequency is calculated:

$$\omega_{st} = \sqrt{\frac{2g}{B (r_{st})^2}} \quad (10)$$

Then compute the dynamic correction factor defined as

$$dcf = 1 - \frac{\omega_s^2}{\omega_{st}^2} = 1 - \frac{(r_{st})^2}{(r_s)^2} \quad (11)$$

Particular attention must be paid to the signs. If, as preferable, the bottom of the tank is above the ship center of gravity, r_{st} is an imaginary number, its square is negative, and the dynamic correction factor becomes greater than unity.

3. Calculation of tank fluid weights

(a) The active weight of tank fluid is the weight of liquid outboard of the nozzles,

$$W_a = \frac{B^3 R (1 - \gamma) C_w}{\text{Spec Vol}} \quad (\text{tons}) \quad (12)$$

(b) The total weight of tank fluid is, in tons

$$W_t = \frac{B^3 R C_w}{\text{Spec Vol}} \left[1 - \gamma \left(1 - \frac{l_c}{l_t} \right) \right] \quad (13)$$

The displacement of the nozzles is ignored for tank design purposes, unless they are especially large.

4. Calculation of tank moments

(a) The tank static stability moment factor, K_t , is simply the transverse moment resulting from transfer of tank liquid due to 1° static heel. For the geometry shown in Fig. 1, and by use of the U-tube analogy:

$$K_t = (.0175) \frac{B^4}{16} \frac{(1 - \gamma^2)(1 + \gamma) C_w}{\text{Spec Vol}} \quad (14)$$

The value of B as shown in Fig. 1 should be in feet, and the resulting K_t will be in foot-tons.

(b) The tank dynamic moment per degree, K_t' , is calculated as the product of K_t and the dynamic correction factor (eq. (11)).

(c) The "figure of merit," representing the effective tank moment related to ship moment is $\frac{K_t'}{K_s}$. From past practice it should be at least .10, and preferably larger. (.12 for preliminary design purposes.)

5. Nozzle design - general

The nozzles are considered to have two major functions:

(1) To assist in getting the desired tank frequency.

(2) To assist in dissipating the energy content of the tank liquid.

These functions are accomplished by inducing high velocity flow and eddying. The nozzles are designed for the first

function by selecting the "choke" area as outlined in 9290-4-d-2-(a). The second function is incorporated into the design from the basic nature of nozzles and by leaving nozzle edges sharp or providing small "tripping bars" at the throat. Various nozzle designs are feasible, and Fig. 1 is not intended to be restrictive. The selection of the detailed shape can be whatever is convenient. Corrections to $(r_t)^2$ to compensate for various obstructions to flow in the cross-over duct can be handled similarly to the nozzles. Table 1 shows a variety of useful nozzle shapes. Types "a", "d", and "e" are used when $\frac{t_c}{t} < 1.0$, while types "a" and "c" are used when $\frac{t_c}{t} = 1$.

6. Analysis of ship plus tank system

Computation of tank performance can be accomplished by the methods in references (c) and (d). Additional demonstration and refinement of roll reduction is obtainable by (a) model testing the tank alone, to check frequency response and moments, (b) model testing the tank plus ship combination, (c) computer studies of the combined ship and tank equations, resulting in a complete spectrum analysis.

7. The reduction in GM due to the tank fluid free surface can be estimated as follows:

$$\begin{aligned} &\text{Approximate GM loss} \\ &= \frac{1}{10} \frac{B \text{ Wt}}{R (\text{Displacement})} \quad (15) \end{aligned}$$

Standard methods should be used for the final configuration to get a more accurate figure.

9290-4-3 Illustrative Example 1

Steps in the Design of a Passive Tank Roll Stabilizer for USS GLACIER (AGB 4). The equation numbers in parentheses refer to the equation in the text which is being used.

1. SHIP PROPERTIES

The design properties of the ship are assumed to be as follows:

Displ. = 7850 tons (representative of a long voyage)
 KM = 35.9 ft (corresponding to 7850 Tons)
 KG = 27.1 ft
 Free Surface correction excludes any stabilizer tank effects
 GM = 8.3 ft
 Beam = 74 ft

$$\text{Roll period, } T = \frac{K(\text{Beam})}{\sqrt{GM}}$$

Assume $K = .44$, then

$$T = \frac{.44 \times 74}{\sqrt{8.3}} = 11.3 \text{ sec} \quad (\text{eq (1)})$$

2. TANK GEOMETRY

By study of the ship plans, a convenient location for the tank is selected. This is on the second deck which in this case is at the 29'-9" WL, forward of bulkhead 146, with a convenient forward extent of 10 frames (14 ft.) and compartment height of about 8 ft. The beam at the center of this region is 73 feet.

$$\text{So } (r_s)^2 = 1.63 \frac{(11.3)^2}{73} = 2.85, (\text{eq(2)})$$

$$\text{preliminary } R = \frac{8}{2 \cdot 73} = .0548 (\text{eq(2)})$$

$$\begin{aligned} t_t = 14 \text{ and } (r_t)^2 &= .826 (2.85) \\ &= 2.35 (\text{desired value}) \end{aligned}$$

It can be seen that this puts the point (point (1)) on Figure 2 below the boundary of the band of values for rectangular tanks. It can be moved into the band by a slightly greater water depth which increases R (and the overall weight) or by increasing the design value of $(r_t)^2$. The latter has a small effect on performance and is preferable. For this tank geometry, ignoring any nozzles for the present, the "active" weight of fresh water (using $\gamma = .6$ and the approximate water depth of 4 ft.):

$$W_a = \frac{(73)^3 \times .0548 \times .4 \times .192}{36}$$

$$= 45.5 \text{ tons} \quad (\text{eq (12)})$$

This is $\frac{45.5}{7850} = .0058$ or 0.58% of the design displacement, and indicates that the tank size selected is reasonable. The total weight of water in the tank (with $l_c/l_t = 1$ for rectangular tank)

$$W_t = \frac{(73)^3}{36} \times .0548 \times .192$$

$$= 113.7 \quad (\text{eq (13)})$$

which represents 1.4% of ship displacement.

3. SHIP AND TANK STATIC MOMENTS

$$K_s = \text{Ship moment to heel } 1^\circ$$

$$= (\text{GM}) (\text{Displacement}) (\tan 1^\circ)$$

$$= 7850 \times 8.3 \times .0175$$

$$= 65,155 \times .0175 = 1140 \text{ ft tons}$$

$$(\text{eq (4)})$$

Tank static moment for 1° (eq (14))

$$\text{list} = K_t = .0175 \frac{B^4}{16} \frac{(1 - \gamma^2)(1 + \gamma)}{\text{Spec Vol}} C_w$$

Using the preliminary value of $b_n = 60\%$ ship beam in way of the tank or $\gamma = .6$, then

$$K_t = \frac{.0175 \times 73^4 (1 - .36)(1.6)(.192)}{16 \times 36}$$

$$= .0175 \times \frac{28.4}{576} \times 10^6 \times .197$$

$$= .0175 \times 9,692 \text{ ft tons} \quad (\text{eq (14)})$$

This is $\frac{9692}{65,155} = 14.9\%$ of moment to heel 1° , and is therefore satisfactory since it is greater than the desired 12% minimum.

4. NOZZLE ARRANGEMENTS

By sketching various practical arrangements of nozzles using square stanchions, the following tentative dimensions result:

$$l_n = 1.5' \quad N = 7 \left. \vphantom{l_n} \right\} \begin{array}{l} \text{(6 inch squares)} \\ \text{Area ratio} = .5 \end{array}$$

$$\eta_n = .793'$$

$$b_n = 44'$$

$$h = 4.1'$$

$$l_t = 14'$$

$$b_t = .707$$

The non-dimensional and other calculated parameters are then

$$R = \frac{4.1'}{73'} = .0562 \quad \gamma = \frac{44'}{73'} = .603$$

$$C_w = \frac{14'}{73'} = .192 \quad \frac{l_c}{l_t} = 1.0$$

$$\omega_s = \frac{2\pi}{11.3} = .556 \text{ rad/sec}$$

$$\frac{\eta_n}{l_n} = \frac{.793}{1.5'} = .529 \quad \frac{N\eta_n}{l_c} = \frac{7 \times .793}{14} = .396$$

First estimate of $(r_t)^2$:

$$r_t^2 = (r_b)^2 = R + \frac{M}{R} \quad (\text{eq (6)})$$

for

$$\frac{l_c}{l_t} = 1.0, \quad \gamma = .603,$$

then

$$M = .158$$

$$(r_b)^2 = .0562 + \frac{.158}{.0562} = .0562 + 2.811 = 2.867$$

Comparing this to the ship non-dimensional period, we find

$$\frac{(r_b)^2}{(r_s)^2} = \frac{2.867}{2.85} = 1.006$$

or

$$\frac{W_t}{W_s} = \sqrt{\frac{1}{1.006}} = .997$$

This ratio is lower than the desired 100% to 110%.

From examination of the equations for M it can be seen that to increase W_t one must decrease $(r_t)^2$. This can be done by

(a) Increasing R . (This will increase volume)

(b) Increasing γ . (This will reduce $\frac{K_t}{K_s}$, and may require increase in l_t .)

The solution to be used here is to increase γ and R . Accordingly, try $b_n = 47$ and $h = 4.33$, and proceed as before.

Now

$$\gamma = \frac{47'}{73'} = .644$$

and

$$R = \frac{4.33'}{73'} = 0.593$$

so that

$$M = .147$$

and

$$(r_b)^2 = .0593 + \frac{.147}{.0593} = .059 + 2.479 = 2.538$$

and

$$\frac{W_t}{W_s} = \sqrt{\frac{2.85}{2.538}} = \sqrt{1.123} = 1.06$$

which is satisfactory. The nozzle correction is now treated,

$$(r_n)^2 = \frac{2A_{ob}}{hBl_c} \left[\frac{l_c F}{\eta_n N} - 1 \right] \quad (\text{eq (7)})$$

where

$$A_o = 14 \frac{(73 - 47)}{2} - \frac{7(.5^2)}{2} = 182 - .9 = 181.1 \text{ ft}^2$$

So

$$(r_n)^2 = \frac{2(181.1)(.707)}{(4.33)(73)(14)} \left[\frac{14 F}{(.793)(7)} - 1 \right] = \frac{256.1}{4425} [2.52 F - 1]$$

for Area Ratio = .5 and

$$\frac{\eta_n}{l_n} = .529, \quad F = .716$$

$$(r_n)^2 = (.0579)(.804) = .046$$

and

$$(r_t)^2 = 2.584$$

so that

$$\frac{W_t}{W_s} = \sqrt{\frac{2.85}{2.584}} = \sqrt{1.103} = 1.05$$

The volume of water is now $4.33' \times 14' \times 73' = 4425 \text{ ft}^3$.

The weight of water is $\frac{4425}{36} = 122.9$ tons, or 1.56% of displacement, which is satisfactory. The new KG = $\frac{(7850 \times 27.1) + (122.9 \times 31.91)}{7850 + 122.9} = 27.17'$

Recalculation of GM (solid) and roll period are not warranted for this change.

5. TANK SECONDARY RESONANCE

$$(r_{st})^2 = \pm 2 \frac{Z_0}{b} \quad (\text{eq (9)})$$

Z_0 is the KG minus height of bottom of tank

$$= 27.1' - 29.75' = -2.65', \text{ a negative number since the tank is above the center of gravity.}$$

Then

$$(r_{st})^2 = -2 \left(\frac{Z_0}{B} \right) = -\frac{2 \times 2.65'}{73'} = -.0726$$

$$\omega_{st} = \sqrt{\frac{2g}{B(r_{st})^2}} = \sqrt{\frac{64.35}{73(-.0726)}} \quad (\text{eq (10)})$$

$$= \sqrt{-12.15} = 3.484i$$

The dynamic correction factor is then

$$\text{dcf} = 1 - \frac{(r_{st})^2}{(r_s)^2} = 1 + \frac{.0726}{2.85}$$

$$= 1.025 \quad (\text{eq (11)})$$

We now recompute K_t , using the revised tank dimensions.

$$K_t = \frac{.0175 \times 73^4 (1 - .415)(1.644)(.192)}{16 \times 36}$$

$$= .0175 \times \frac{28.4}{576} \times 106 \times 1.85 \quad (\text{eq (14)})$$

$$= .0175 \times 9122 \text{ ft tons.}$$

Neglecting the small change in GM caused by the tank weight,

$$\frac{K_t}{K_s} = \frac{.0175 \times 9122}{.0175 \times 65,155} = .14$$

and

$$K'_t = K_t \left(1 - \frac{\omega_s^2}{\omega_{st}^2} \right) = .14 \times 1.025$$

$$= .144$$

Note that if diesel oil is used in the tank, K_t becomes

$$.0175 \times 9122 \times \frac{36}{43} = .0175 \times 7637$$

and

$$\frac{K_t}{K_s} = .117, \quad K'_t = .117 \times 1.025 = .12$$

This is in accordance with usual practice.

Accordingly, the tank design, using the notation of Fig. 1, will have

$$B = 73'$$

$$b_n = 47'$$

$$l_t = 14'$$

$$\eta_n = .793'$$

$$l_n = 1.50'$$

$$h = 4.33'$$

$$N = 7$$

This concludes the design phase for this example.

9290-4-f Illustrative Example 2

1. SHIP PROPERTIES

Full load displacement 4400 tons
 Light ship displacement 2000 tons
 Design displacement for tank
 = $2000 + 2/3(4400 - 2000) = 3600$
 tons

Design GM for tank 3.76 ft
 Beam 51.5 ft
 Assumed center of roll, 15 ft above
 baseline

Estimated roll period

$$T = \frac{.44 \times 51.5}{\sqrt{3.76}} = 11.7 \text{ sec} \quad (\text{eq (1)})$$

$$\omega_s = \frac{2\pi}{T} = .537$$

2. TANK GEOMETRY

The location selected for this tank is low in the ship so that KG is 5 feet above the tank bottom, the available width for the tank is 50 feet, and the compartment height is 9 feet. The desired liquid here is to be fresh water.

Then with $B = 50$,

$$(r_s)^2 = \frac{1.63}{50} \times 11.68^2 = 4.46 \quad (\text{eq (2)})$$

$$(r_t)^2 \text{ desired} = .826 \times 4.45 = 3.68 \quad (\text{eq (3)})$$

The possible value of R using half the compartment height is

$$R = \frac{9}{2 \times 50} = .09$$

From Figure 2 (point 2) can be seen that the tank should have a narrow crossover duct. In order to enter Figure 3, temporarily use the approximation that $(r_t)^2 = (r_b)^2$. Then $M = R((r_b)^2 - R)$ from eq (6))

$$M \text{ desired} = .09 (3.68 - .09) = .323$$

For this value of M , two points in the "useful range" of γ and $\frac{l_c}{l_t}$ are:

$$1. \quad \gamma = .46, \quad \frac{l_c}{l_t} = .5 \text{ and}$$

$$2. \quad \gamma = .625, \quad \frac{l_c}{l_t} = .41$$

These values are found from Fig. 3 by assuming γ and then interpolating or else cross-fairing M vs. $\frac{l_c}{l_t}$. For both tanks,

$$(r_{st})^2 = +2 \times \frac{5}{50} = +.2 \quad (\text{eq (9)})$$

Then the dynamic correction factor is

$$\left(1 - \frac{(r_{st})^2}{(r_s)^2}\right) = 1 - \frac{.2}{4.46} = .955 \quad (\text{eq (11)})$$

Checking these for static moment, with C_w as yet undetermined,

$$1. \quad K_t = .0175 \times \frac{50^4}{16} (1 - .212) \times \frac{1.46 \times C_w}{36} \\ = .0175 \times 12,500 C_w \frac{\text{ft tons}}{\text{degree}} \quad (\text{eq (14)})$$

$$2. \quad K_t = .0175 \times \frac{50^4}{16} (1 - .391) \times \frac{1.625}{36} C_w \\ = .0175 \times 10,700 C_w \frac{\text{ft tons}}{\text{degree}} \quad (\text{eq (14)})$$

Then in order that $K_t' = .12 K_s$

$$1. \quad \frac{12,500 \times .955 C_w}{3.76 \times 3600} = .12 \text{ or} \\ C_w = .136 = .14$$

$$2. \quad \frac{10,700 \times .955 C_w}{3.76 \times 3600} = .12 \text{ or} \\ C_w = .159 = .16$$

$$\text{So for case 1, } l_t = .14 \times 50 = 7.0' \\ \text{case 2, } l_t = .16 \times 50 = 8.0'$$

The weights of tank water for these two cases are (eq (13))

$$1. \quad W_t = \frac{50^3 \times .09}{36} \times .14 [1 - .46 (1 - .5)] \\ = 312.5 \times .108 = 33.8 \text{ Tons}$$

$$2. \quad W_t = 312.5 \times .16 [1 - .625 (1 - .41)] \\ = 312.5 \times .101 = 31.6 \text{ Tons}$$

These represent respectively 0.94% and .88% of the Design Displacements, or 0.77% and 0.72% of Full Load Displacement. The "lever arm" or Moment per Ton of these are respectively 6.47 ft and 5.92 ft. Using these values as a guide, and reconsidering the value of C_w in the light of practical frame-spacing, the following tank configuration is selected:

$$\begin{aligned} h &= 4.5' & R &= .09 \\ l_t &= 8' & & \\ b_n &= 24' & C_w &= .16 \\ l_c &= 4' & \gamma &= .48 \\ & & \frac{l_c}{l_t} &= .5 \end{aligned}$$

From figure 3, $M = .317$

$$(r_b)^2 = .09 + \frac{.317}{.09} = 3.61 \quad (\text{eq (6)})$$

$$\begin{aligned} Kt &= .0175 \times \frac{50^4}{16} (1-.230)(1.48) \times \frac{.16}{36} \\ &= .0175 \times 1978 \quad (\text{eq (14)}) \end{aligned}$$

$$\frac{Kt'}{Ks} = \frac{1978 \times .955}{3.76 \times 3600} = .14.$$

This is greater than the desired 12% min.

$$\begin{aligned} \text{Total weight} &= \frac{50^3 \times .09}{36} \\ &\quad \times .16 [1 - .48(1-.5)] \\ &= 38 \text{ T} \quad (\text{eq (13)}) \end{aligned}$$

This represents 1.06% of the Design Displacement or 0.86% of Full Load, with a "moment arm" of 9.11 ft.

The nozzles selected for this type of tank usually are conveniently located at the corners of the entrance to the crossover duct. The portion on the outboard tank may be rounded to improve the flow from the tank to the crossover duct, while the inboard portion of the nozzles should have a fairly easy taper, approximately one

in two or easier. Figure 5 shows the configuration selected for this example, with the following properties:

$$\begin{aligned} b_1 &= 33'' = 2.75' & \frac{b_1}{l_c} &= .688 \\ \frac{N\eta_n}{l_c} &= \frac{\eta_n}{l_c} = \frac{\eta_n}{l_n} = .625 \\ \eta_n &= 30'' = 2.5' & \frac{\eta_n}{l_n} &= .625 \\ l_n &= 4' \\ \frac{d}{r} &= \frac{24}{9} & \frac{r}{d} &= \frac{9}{24} = .375 \\ \text{arc cos}(.375) &= .386 \text{ rad} \end{aligned}$$

$$\begin{aligned} \text{Area ratio} &= \frac{\pi + \sqrt{2.667^2 - 1} - .386}{2(2.667+1)} \\ &= \frac{\pi + 2.472 - .386}{7.334} = .713 \end{aligned}$$

Then from figure 4, $F = .876$ and

$$\begin{aligned} (r_n)^2 &= \frac{(1-.48) \cdot .16}{.09} \times .688 \left[\frac{.876}{.625} - 1 \right] \\ &= .636 \times .402 = .104 \quad (\text{eq (7)}) \\ &= 3.61 + .10 = 3.71 \quad (\text{eq (5)}) \end{aligned}$$

With this new tank dimensionless period,

$$\omega_t = \sqrt{\frac{2g}{50 \times 3.71}} = .589 \quad (\text{eq (8)})$$

The tank tuning ratio is

$$\frac{.589}{.538} = 1.09$$

The dynamic correction factor is (eq (11))

$$1 - \frac{.2}{4.46} = .955, \text{ unchanged}$$

The approximate loss in GM due to the tank free surface is (eq (15))

$$\begin{aligned} \text{GM loss} &= \frac{1}{10} \frac{B W_t}{R \Delta} = \frac{50 \times 38}{10 \times 2000 \times .09} \\ &= 1.06 \text{ ft.} \end{aligned}$$

Summary of Equations

Eq

- (1) $T(\text{roll}) = \frac{(K) (\text{Ship Beam})}{\sqrt{GM}} (\text{sec}) \quad .38 \leq K \leq .44$
- (2) $(r_s)^2 = \frac{g T^2}{2\pi^2 B} = 1.63 \frac{T^2}{B} = \frac{2g}{B\omega_s^2}$
- (3) $(r_t)^2 = 0.826(r_s)^2$ (desired)
- (4) $K_s = .0175 \Delta GM$ (ft tons)
- (5) $(r_t)^2 = (r_b)^2 + (r_n)^2$
- (6) $(r_b)^2 = \mathcal{R} + \frac{M}{\mathcal{R}}$
- (7) $(r_n)^2 = \frac{2Aob_l}{hBl_c} \left[\frac{lcF}{N\eta_n} - 1 \right]$
- (8) $\omega_t = \sqrt{\frac{2g}{B(r_t)^2}}$ (radians per sec)
- (9) $(r_{st})^2 = \pm 2 \frac{Z_o}{B}$
- (10) $\omega_{st} = \sqrt{\frac{2g}{B(r_{st})^2}}$ (radians per sec)
- (11) $dcf = 1 - \frac{\omega_s^2}{\omega_{st}^2} = 1 - \frac{(r_{st})^2}{(r_s)^2}$
- (12) $W_a = \frac{B^3 \mathcal{R} (1-\gamma) Cw}{\text{Spec Vol}}$ (Tons)
- (13) $W_t = \frac{B^3 \mathcal{R} Cw}{\text{Spec Vol}} \left[1 - \gamma \left(1 - \frac{lc}{lt} \right) \right]$ (Tons)
- (14) $K_t = \frac{.0175 B^4 (1-\gamma^2)(1+\gamma) Cw}{16 \text{ Spec Vol}}$ (ft Tons per degree)
- (15) $GM \text{ loss} = \frac{1}{10} \frac{B W_T}{\mathcal{R} \Delta}$

TABLE OF AREA RATIOS



NOZZLE TYPE	AREA RATIO
(a) 	.5
(b) 	1.0
(c) 	.785
(d) 	$\frac{\pi + 2 \frac{d}{r}}{4(1 + \frac{d}{r})}$
(e) 	$\frac{\pi + \sqrt{(\frac{d}{r})^2 - 1} - \text{arc cos } r/d}{2(\frac{d}{r} + 1)}$

TABLE I

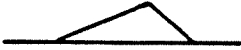

NOMENCLATURE FOR DETERMINATION
 OF TANK PROPERTIES

FIG 1

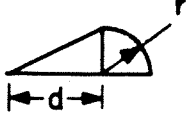
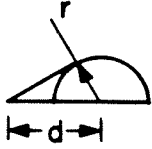
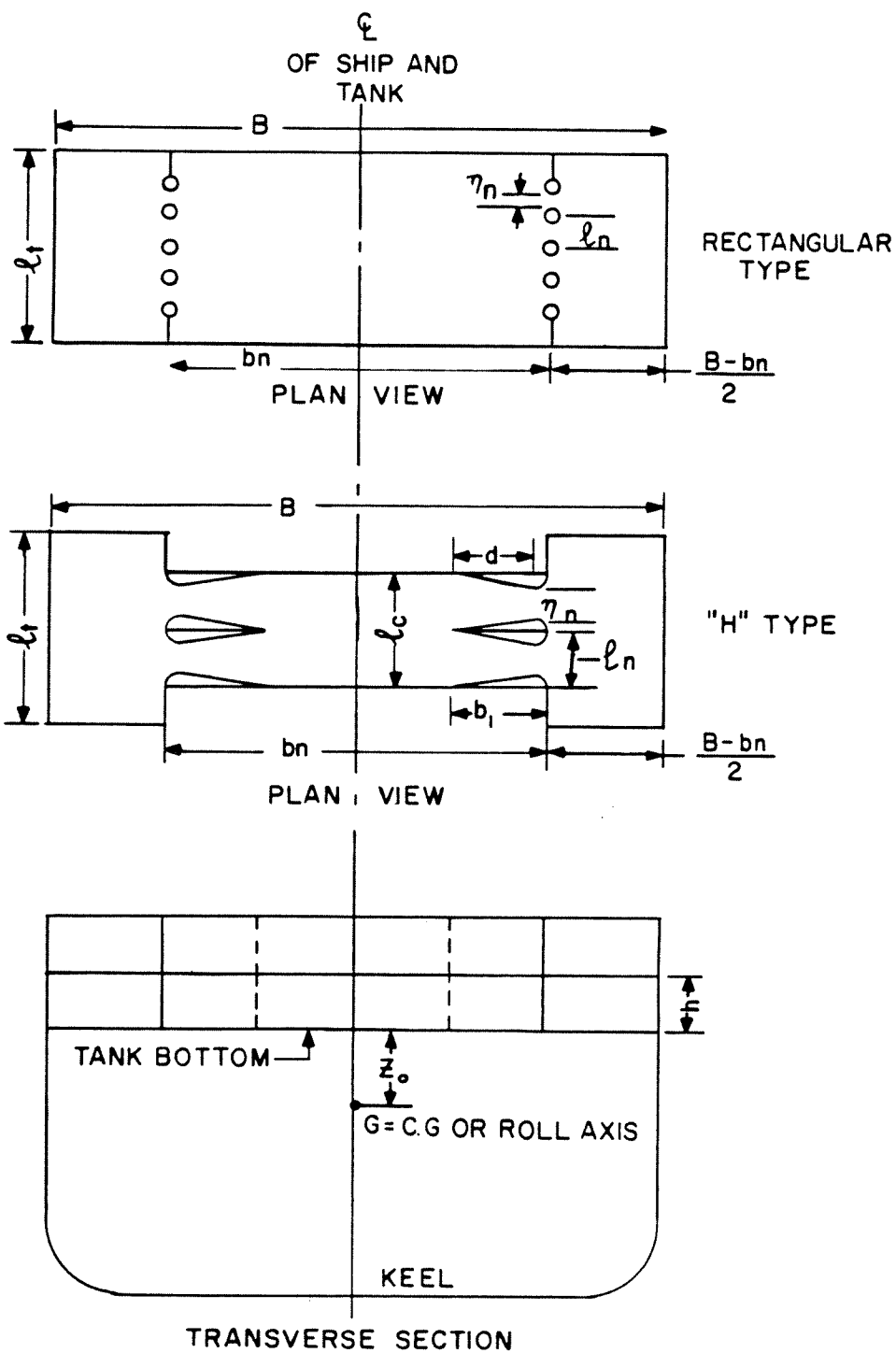
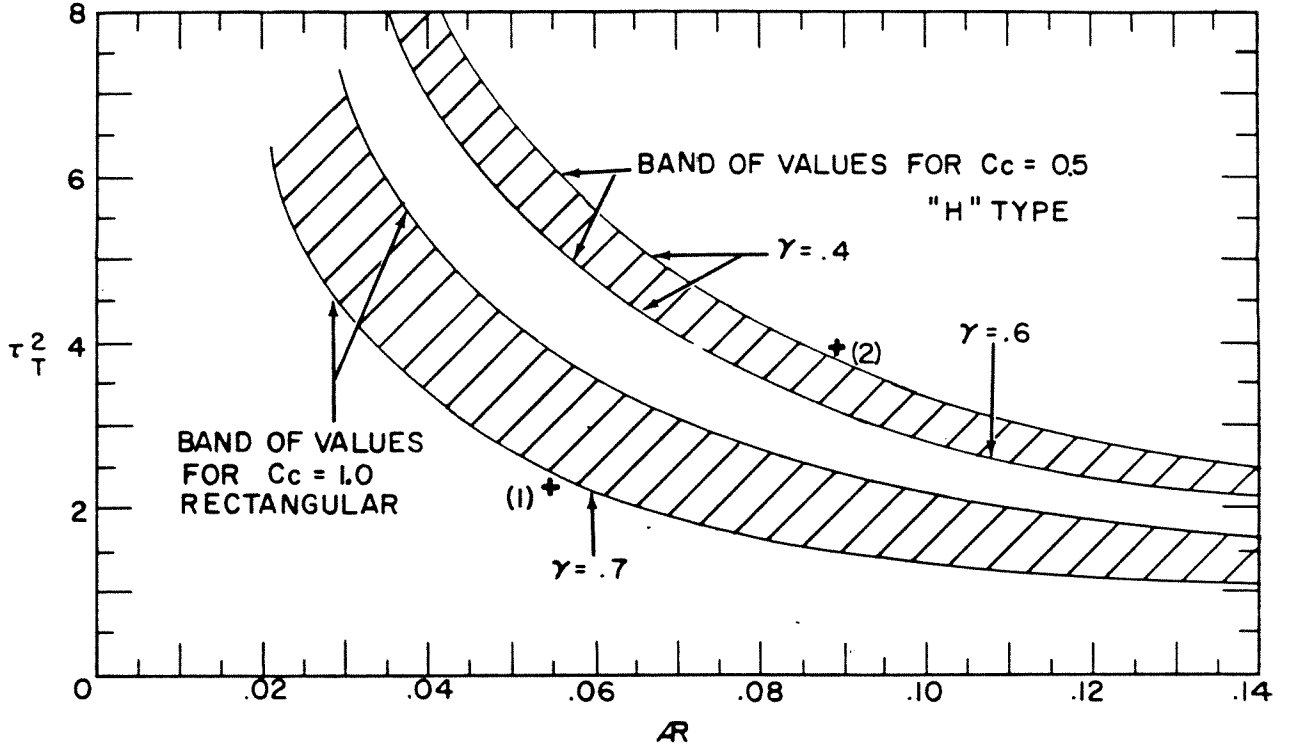

FIG. 2

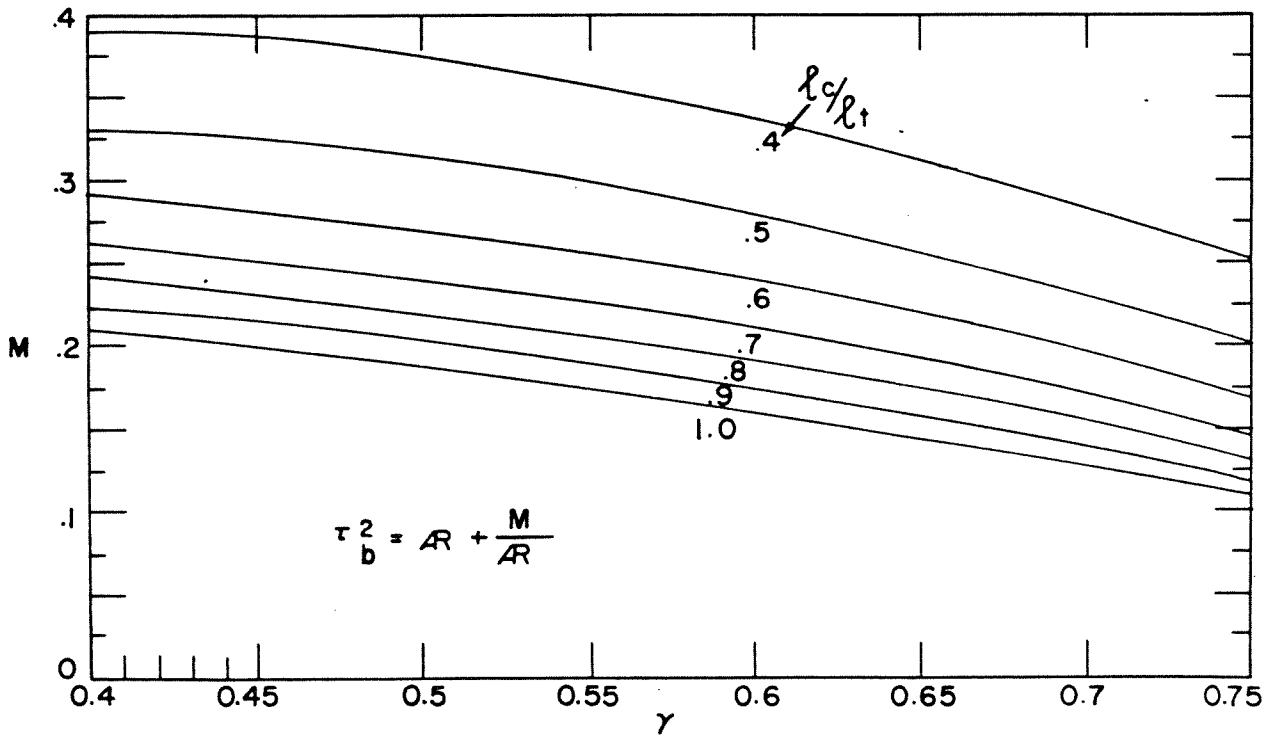
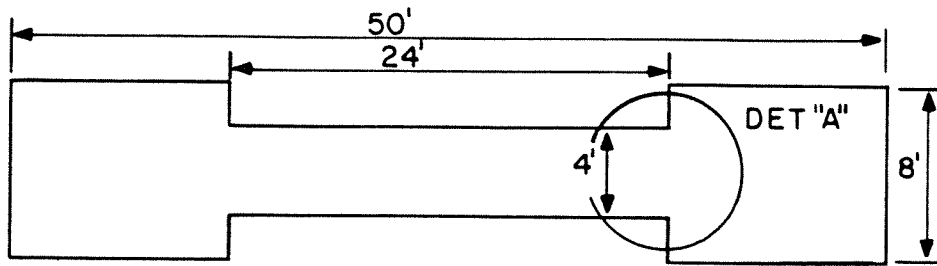
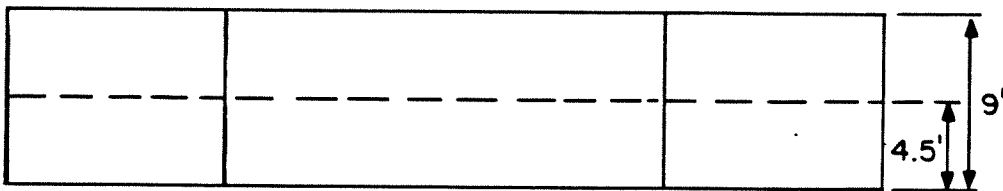

FIG. 3



PLAN VIEW



TRANSVERSE SECTION

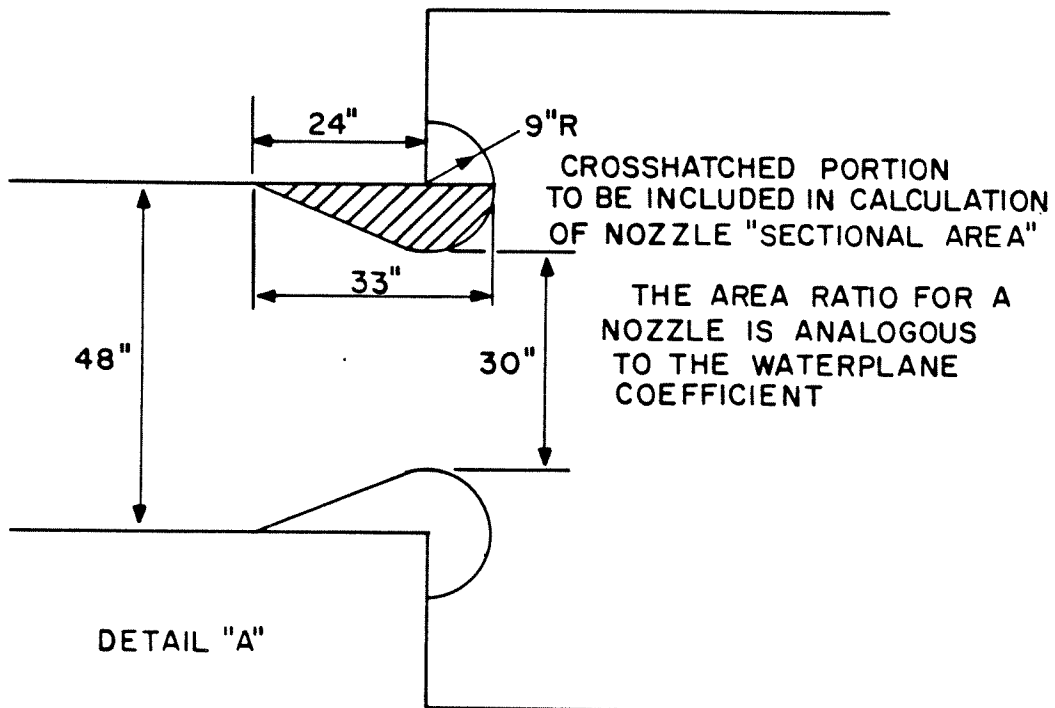

EXAMPLE 2

FIG 5

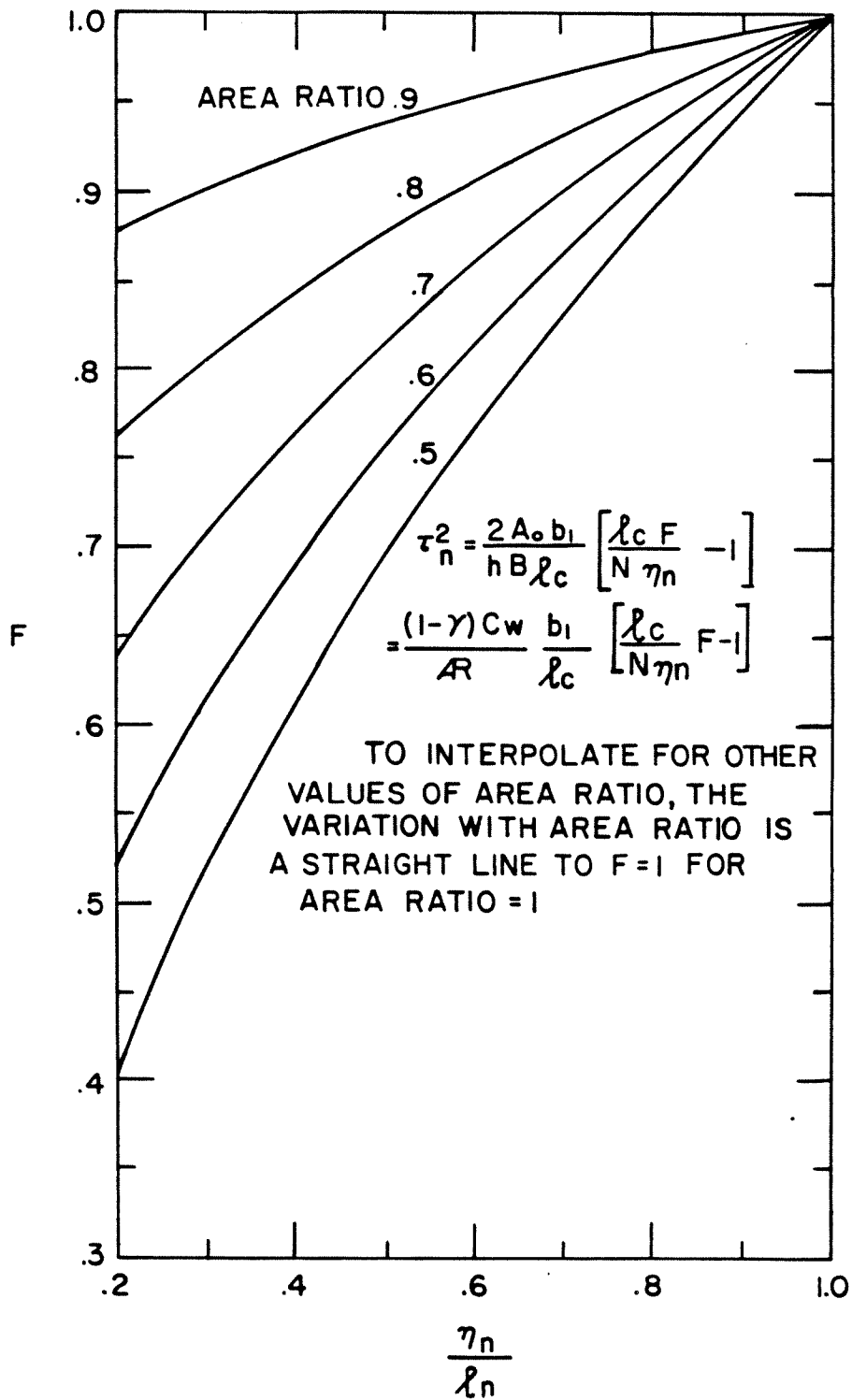

CURVES OF F vs $\frac{\eta_n}{\lambda_n}$ FOR VARIOUS VALUES OF AREA RATIO