



**MCTP 3-10B
(Formerly MCWP 3-12)**

Marine Corps Tank Employment



U.S. Marine Corps

DISTRIBUTION STATEMENT A: Approved for public release; distribution is unlimited.



PCN 147 000037 00

DEPARTMENT OF THE NAVY
Headquarters United States Marine Corps
Washington, D.C. 20350-3000

4 April 2018

CHANGE 1 to MCTP 3-10B
Marine Corps Tank Employment

1. This publication has been edited to ensure gender neutrality of all applicable and appropriate terms, except those terms governed by higher authority. No other content has been affected.
2. File this transmittal sheet in the front of this publication.

Reviewed and approved this date.

BY DIRECTION OF THE COMMANDANT OF THE MARINE CORPS



ROBERT S. WALSH
Lieutenant General, U.S. Marine Corps
Deputy Commandant for Combat Development and Integration

Publication Control Numbers:

Publication: 147 000037 00

Change: 147 000037 01

CD&I (C 116)

2 May 2016

ERRATUM

to

MCWP 3-12

MARINE CORPS TANK EMPLOYMENT

1. Change all instances of MCWP 3-12, *Marine Corps Tank Employment*, to MCTP 3-10B, *Marine Corps Tank Employment*.
2. Change PCN 143 000145 00 to PCN 147 000037 00.
3. File this transmittal sheet in the front of this publication.

PCN 147 000037 80

DEPARTMENT OF THE NAVY
Headquarters United States Marine Corps
Washington, D.C. 20380-1775

21 March 2014

FOREWORD

Marine Corps Warfighting Publication (MCWP) 3-12, *Marine Corps Tank Employment*, provides Marine Corps doctrine and supporting tactics, techniques, and procedures for the employment of Marine tanks in support of the Marine air-ground task force (MAGTF).

Historically, Marine tanks have often played critical roles in the success of Marine Corps combat operations. From World War II, the Marine commander's ability to employ Marine tanks effectively has provided Marines with a devastating direct fire capability. Today, Marine M1A1 Abrams tanks are the most lethal direct fire and survivable weapon system within the arsenal of the ground combat element.

This publication is intended for Marine Corps combat, combat support, and combat service support unit commanders and their staffs operating with or supporting Marine tank units. It describes how the Marine Corps employs tanks across the range of military operations and focuses on preparing, planning, and conducting MAGTF operations with tanks.

This publication supersedes MCWP 3-12, *Marine Corps Tank Employment*, which is dated 17 February 2005.

BY DIRECTION OF THE COMMANDANT OF THE MARINE CORPS



K. J. GLUECK, JR.
Lieutenant General, U.S. Marine Corps
Deputy Commandant for Combat Development and Integration

Publication Control Number: 143 000145 00

DISTRIBUTION STATEMENT A: Approved for public release; distribution is unlimited.

This Page Intentionally Left Blank

TABLE OF CONTENTS

Chapter 1. Organizational Structure

Tank Battalion	1-1
Organization	1-1
Command and Control	1-1
Employment	1-2
Planning	1-3
Tank Company	1-3
Employment	1-3
Organization	1-3
Command and Control	1-4

Chapter 2. Operations

Offensive Operations	2-1
Types of Offensive Operations.	2-1
Forms of Maneuver	2-3
Defensive Operations	2-4
Types of Defensive Operations	2-4
Planning Considerations for Tanks in the Defense	2-5
Defensive Methods.	2-5
Other Tactical Operations in the Defense.	2-6
Stability Operations	2-6
Force Protection	2-7
Public Affairs and the Media	2-7
Counterinsurgency Operations	2-7
Noncombatant Evacuation Operations.	2-7
Security.	2-8
Evacuation Route Clearance.	2-8
Other Tactical Operations.	2-8
Security Operations	2-8
Reconnaissance by Fire	2-8
River Crossing	2-8
Passage of Lines	2-9
Tactical Road March	2-9
Assembly Area	2-9
Convoy Security Operations.	2-9
Cordon and Search	2-9
Control Points.	2-9
Reaction Force	2-9

Chapter 3. Employment with Infantry

Task Organization	3-1
Mechanized Task Force	3-2
Company Team	3-2
Coordination	3-2
Mutual Support	3-3
Employment Methods	3-3
Tanks and Mechanized Infantry Attack Together	3-3
Tanks and Amphibious Assault Vehicle Support by Fire	3-4
Maneuver Considerations	3-5
Dismounting	3-5
Dismount Short of the Objective	3-5
Dismount on the Objective	3-5
Dismount After Passing Through the Objective	3-6
Consolidation and Reorganization	3-6
Transporting Infantry	3-6

Chapter 4. Tactical Logistics

Trains	4-1
Company Trains	4-1
Combat Trains	4-1
Field Trains	4-1
Organic Capabilities	4-1
Identify Critical Requirements	4-1
Safeguard Resources	4-2
External Support	4-2
Prioritize Requirements	4-2
Respond Rapidly	4-2
Resupply Operations	4-2
Resupply Methods	4-2
Resupply Techniques	4-3
Maintenance Operations	4-4

Chapter 5. Amphibious Operations

Planning Considerations	5-1
Embarkation Plan	5-1
Landing Plan	5-1
Intelligence Requirements	5-1
Embarkation/Debarcation	5-2
Environmental Characteristics	5-2
Fording Kit Characteristics	5-2
Embarkation/Debarcation Planning Considerations	5-2
Responsibilities	5-3

Chapter 6. Military Operations on Urbanized Terrain

Tank Units and the Infantry	6-1
Planning	6-2
Employment Considerations.	6-3
Control Measures	6-5
Offensive Military Operations on Urbanized Terrain	6-5
Attacking in Urban Areas.	6-6
Attack Phases	6-6
Defensive Military Operations on Urbanized Terrain	6-7
Defensive Planning Considerations	6-8
Defensive Techniques.	6-8
Fighting Positions.	6-8

Chapter 7. Scout and Antitank Platoons

Scout Platoon	7-1
Mission	7-1
Organization	7-1
Employment	7-1
Reconnaissance Missions	7-2
Additional Tasks for Scout Platoon	7-2
Capabilities and Limitations.	7-3
Antitank Platoon.	7-3
Mission	7-3
Organization	7-3
Employment	7-3
Capabilities and Limitations.	7-4

Appendices

A Armor Vehicle Characteristics	A-1
B Logistic Considerations	B-1
C Operations in Extreme Environments.	C-1
D Chemical, Biological, Radiological, and Nuclear Operations	D-1
E Breaching Operations	E-1
F Ammunition	F-1

Glossary

References

This Page Intentionally Left Blank

CHAPTER 1

ORGANIZATIONAL STRUCTURE

The operational success of the Marine air-ground task force (MAGTF) requires the coordinated employment of all MAGTF resources, such as reconnaissance, infantry, aviation, tanks, artillery, engineers, amphibious assault vehicles (AAVs), and other combat support and combat service support (CSS) units. Across the range of military operations, all elements of the MAGTF, including tank units, are employed to achieve the effects of combined arms against enemy forces.

Tank units, as maneuver elements, provide the MAGTF commander the ability to attack, disrupt, and destroy enemy forces through armor protection, shock effect, rapid maneuver, and precise long-range direct fires in coordination with other elements of the MAGTF. The tank is designed primarily as an offensive weapon, regardless of the type of operation (defensive or offensive) conducted. The M1A1 tank offers the MAGTF many complementary capabilities, such as excellent cross-country mobility, sophisticated communications, enhanced day and night target acquisition, lethal firepower to defeat enemy mechanized platoons, precision lethal effects while operating within restrictive rules of engagement (ROE), and highly effective armor protection.

Tank Battalion

The tank battalion provides the ground combat element (GCE) commander with the employment flexibility and capabilities that can contribute to a decisive victory on a dynamic battlefield. When integrated with the MAGTF, its armor-protected firepower, shock, and maneuver make tank battalions effective combat units.

Currently, the Marine Corps has two active duty tank battalions and one reserve tank battalion:

- 1st Tank Battalion, 1st Marine Division.
- 2d Tank Battalion, 2d Marine Division.
- 4th Tank Battalion, 4th Marine Division.

Organization

A tank battalion consists of four tank companies, a headquarters and service company, one antitank platoon, and one scout platoon (see fig. 1-1 on page 1-2). The tank companies, each consisting of 14 M1A1 tanks, are the basic tactical unit with which the battalion accomplishes its mission. The antitank platoon, which consists of 24 Saber missile systems and 4 heavy machine gun trucks, provides additional precision and long-range direct fires to the battalion. The scout platoon, which consists of six heavy machine gun trucks and two Saber missile systems, performs reconnaissance, provides limited security, and assists in controlling the movement of the battalion.

Command and Control

The command post is organized into three groups—the main command post, the forward command post, and the administration and logistics operation coordination center:

- The main command post is the primary means of controlling maneuver companies/teams and is responsible for maintaining digital communication with higher headquarters.
- The forward command post is a purpose-built command and control organization that maintains connectivity and control with lead elements. Usually, the commander is collocated

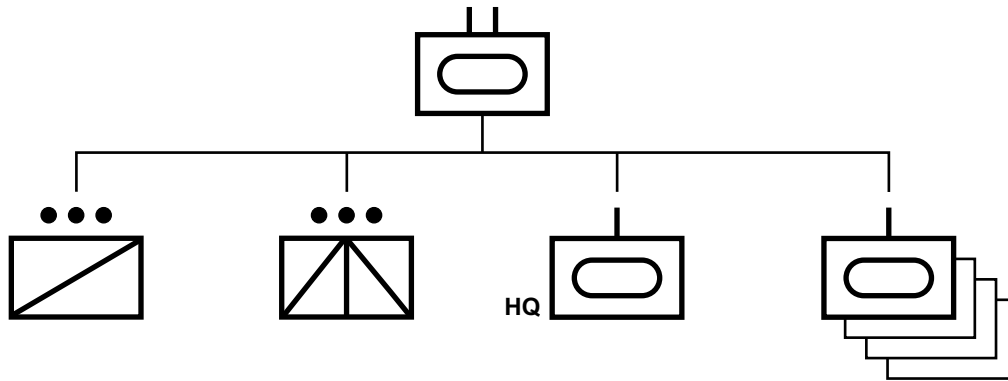

Figure 1-1. Marine Tank Battalion Organization.

with this element to direct and monitor the battle. The forward command post usually consists of the amphibious assault vehicle command model 7, a chase amphibious assault vehicle personnel model 7, and the battalion commander's tank section.

- The administration and logistics operation coordination center coordinates the sustainment of the battalion while maintaining connectivity with the designated CSS unit and the combat operations center. Additionally, the administration and logistics operation coordination center provides a tertiary operations center to provide command and control when the forward and main command posts are incapacitated or merged to plan follow-on operations.

The commander retains flexibility when commanding the battalion/task force forward in the jump configuration. The jump is a subset of the forward command post and consists of the headquarters tank section.

Employment

The tank battalion is best employed as a task force that is able to cross-attach units down to the platoon level and employ units down to the section level. The GCE commander can create mechanized forces by task-organizing tank, mechanized infantry, and other combat support

and CSS units based on mission, enemy, terrain and weather, troops and support available-time available (METT-T) and METT-T and space and logistics available.

Leaders should have a clear understanding of the capabilities and limitations of their equipment in order to employ them effectively. Appendix A provides a list of the specifications, characteristics, and significant features of the M1A1 main battle tank and its supporting equipment. Offering all weather, day/night capabilities to the MAGTF, the tank battalion also provides precision long-range protected firepower, maneuver, shock effect, robust organic sustainability capabilities:

- *Precision long-range protected firepower.* The tank battalion provides the ability to mass the effects of 58 M1A1 tanks and 26 Saber missile systems against most threats on the battlefield with the capability to simultaneously control all combined supporting arms available to the MAGTF.
- *Maneuver.* The tank battalion is capable of rapidly employing combat forces across the MAGTF's area of operation, quickly massing for employment at a decisive time and place according to the commander's estimate of the situation.
- *Shock effect.* The tank battalion creates both a physical and psychological effect through precision fires, speed, mobility, and physical

presence. While shock effect primarily attempts to influence enemy action/inaction, it can also have a favorable effect on the morale of friendly forces and security of indigenous populations.

- *Robust organic sustainability.* The tank battalion, with its organic third echelon maintenance capability and significant lift and recovery capacity, can logistically support subordinate elements dispersed throughout the MAGTF's area of operation, task-organizing its organic CSS assets. The tank battalion can also support attachments and adjacent units and routinely reaches back to assist with logistic distribution throughout the battlespace. See appendix B for battalion lift capacity and logistic capabilities and requirements.

Planning

Maintenance and mobility are two employment considerations that are unique in scope to tank battalions. The MAGTF commander must have a thorough understanding of these constraints in order to plan the effective employment of the tank battalion's combat power.

Maintenance

The sustainment of a battalion's significant combat capacity requires a dedicated maintenance effort. Tank battalions conduct preventive and corrective maintenance during halts, rest periods, and scheduled periods of resupply to minimize the impact on combat operations. Systematic relief of subordinate tank units permits thorough maintenance in order to sustain and maintain operational tempo. Appropriate planning by commanders at all levels will ensure operational readiness and continuous employment.

Mobility

Because it is a tracked vehicle with a turbine engine, the M1A1 tank achieves tempo and precise armor-protected firepower better than any other platform in the GCE. The M1A1 tank possesses the best cross-country mobility in the MAGTF; however, that mobility is affected most

significantly by fuel consumption. Fuel consumption is operationally-dependent, so continuous operations will significantly increase it.

Deliberate planning for Class III (petroleum, oils, and lubricants) resupply is done throughout operations to prevent operational tempo disruption. The tank battalion possesses the vehicular capacity to provide 25,200 gallons of fuel, a one-day supply of Class III. Within this day's supply of Class III, the tank battalion still possesses the ability to provide support to attached and adjacent units in the area of operation. Appendix C discusses tank capabilities and limitations in extreme environments.

Tank Company

The tank company provides the tank battalion with a maneuver element that has the flexibility to task-organize to suit the mission. Its organic logistic support allows it to retain some maneuver freedom from the battalion.

Employment

The tank company is best employed as a maneuver element with the ability to detach units down to the platoon level. The commander can create mechanized forces by task-organizing tank, mechanized infantry, and other combat support based on METT-T and space and logistics available. Employment of the tank company must take advantage of the speed, mobility, and firepower of the organization.

Organization

A tank company consists of 3 tank platoons and a headquarters section (see fig. 1-2 on page 1-4). The tank platoons, each consisting of 4 M1A1 tanks, are the basic tactical unit with which the company accomplishes its mission. Tank companies possess an organic logistic capacity in the company trains. Organic assets include 2 M88A2 retrievers, 1 medium tactical vehicle replacement (MTVR) with 105 trailer, 1 MRC-145, 6 high mobility

multipurpose wheeled vehicles (HMMWVs), and 2 armored HMMWVs. The tank company, when cross-attached to an infantry battalion, possesses a robust company train that is able to provide Class I (rations), III, and V (ammunition) items.

Command and Control

The tank company commander has an amplified very high frequency (VHF) capability that allows

command and control of subordinate units across greater distances and terrain than is allowable by Marine-portable systems. The installation of forward observer/forward air controller (FAC) kits allows the tank company fire support team (FST) to control MAGTF fires from any M1A1 platform, allowing the use of UHF [ultra high frequency] and additional VHF radios to support the forward observer and FAC assigned to the company.

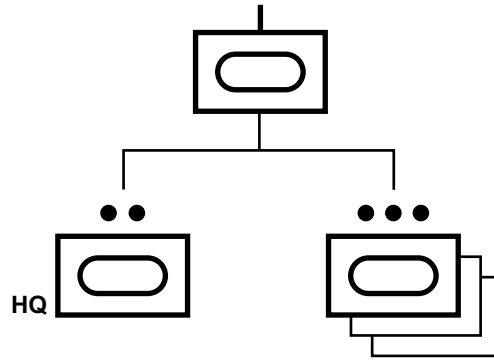

Figure 1-2. Marine Tank Company Organization.

CHAPTER 2

OPERATIONS

Offensive Operations

When the MAGTF is involved in offensive operations, the main effort is weighted with superior combat power, which allows the MAGTF to retain the initiative, set the tempo of operations, and achieve decisive results on the battlefield. Tank units, with their inherent speed, mobility, armor-protected firepower, and shock effect, contribute greatly to the GCE's combat power while operating in the offense. Tank units also provide the GCE with flexibility that allows the commander to rapidly shift his/her main effort. The inherent flexibility of a tank unit allows the commander to maintain the momentum of attack by quickly focusing the combat power of the force at various locations on the battlefield.

Types of Offensive Operations

There are four general types of offensive operations: movement to contact, attack, exploitation, and pursuit. A more detailed discussion of each type of offensive operation can be found in Marine Corps Doctrinal Publication (MCDP) 1-0, *Marine Corps Operations*.

Movement to Contact

A properly executed movement to contact allows the tank battalion commander to make initial contact with minimum forces and to expedite the employment and concentration of the force. A tank battalion's organic scout platoon provides reconnaissance assets to gain and maintain contact with enemy forces, allowing tank units time to deploy. A tank force conducting a movement to contact normally organizes in an approach march formation with advance, flank, and rear guard elements protecting the main body.

A tank company usually provides the advance guard element for a tank or mechanized battalion (the main body). As the company moves along the axis of advance, it usually will have a 3- to 5-kilometer frontage if unhindered by terrain or obstacles. The following are tank advance guard responsibilities:

- *Destroying enemy reconnaissance units.* Tanks are well suited to destroy enemy mechanized and dismounted reconnaissance due to their ability to acquire and destroy targets at long ranges and to mass fires quickly (day or night).
- *Finding, fixing, defeating, destroying, or containing enemy security forces.* A tank unit has a superior ability to make initial contact with a small element, rapidly concentrate forces, and mass the effects of fires in order to retain freedom of maneuver for the main body.
- *Calling for indirect fires/close air support to impede or harass the enemy.* The advance guard for a tank battalion usually has a forward observer and FAC located with it at the company command level to help execute indirect fire/close air support missions. The far target location (FTL) on the tank enables the generation of a 10-digit grid, range, and direction up to 8 kilometers, making FST procedures far more responsive and efficient.
- *Reporting, bypassing, or breaching obstacles using breaching tools organic to a tank unit.* The employment of the track-width mine plow and tank blade gives the tank company an in-stride breaching capability.

Tank formations can be used for flank or rear guard; however, within the combined arms team, a tank unit is best employed as a main body or advance guard. A flank or rear guard mission will not fully utilize the decisive combat power of tank units. Due to their mobility, firepower, and

shock effect, tank units are ideally suited to conduct an attack against main enemy forces and comprise the main body during the movement to contact. Elements from the main body may be deployed to eliminate small pockets of resistance bypassed by the advance guard. Tanks possess the ability to rapidly maneuver to destroy an enemy threat and reconstitute formations oriented on follow-on actions. After destruction or defeat of the enemy, the armor and mobility inherent to tank units make them well suited for follow-on missions, such as exploitation, establishment of a hasty defense, or rapid formation of a reserve force to prepare for counterattack.

Attack

An attack emphasizes maximum application of combat power coupled with bold maneuver, shock effect in the assault, and prompt exploitation of success. Tank units possess the ability to rapidly concentrate a decisive force and quickly disengage, making them suitable for conducting spoiling attacks. When using tank units during an attack, commanders should consider the following:

- Conducting a line of sight analysis to identify advantageous positions for tanks and other weapon systems to support by fire.
- Planning for the resupply of fuel and ammunition expenditures.
- Using infantry to support tanks whenever possible to provide local security.
- Using the tank's main gun to destroy enemy armor, light armor, and field fortifications.
- Extending the maneuver space due to the mobility of the tank.

Tank units counterattack using two methods: fire or fire and maneuver. The intent of the counterattack by fire is to use weapon standoff from a position of advantage to destroy the enemy by fire; whereas, the intent of the counterattack by fire and maneuver is to close with and destroy the enemy.

Tanks are effective in confusing the enemy into thinking they are being attacked by the main

effort when they are not. The appearance of tanks attacking can cause the enemy commander to commit his/her reserve forces to counter the feint, leaving no reserves when the main body attacks the enemy from a different direction/place.

The employment of a tank unit in a feint must be heavily weighed against the combat power that is rendered unavailable to the main effort. The employment of a tank unit in a demonstration must be weighed against the potential loss of combat power that could be applied to the main effort.

The protection afforded by the tank battalion will add significant combat power to the force. When included, a tank unit can rapidly exploit any vulnerability identified in enemy formations. Since a reconnaissance in force is conducted when knowledge of the enemy is vague, combined arms forces often employ tanks to ensure disengagement of the force if superior enemy forces are encountered.

Tanks can be employed on mechanized raids to destroy enemy installations and facilities, disrupt enemy command and control or support activities, divert enemy attention, and secure information. The tank's ability to engage targets at extended ranges with precision surprises enemy forces. Additionally, the mobility and speed provided by the tank allows for rapid displacement once actions are complete.

Exploitation

Tank units, down to the platoon level, are ideally suited for exploitation operations because of their inherent speed, mobility, and shock action. Due to their speed, mobility, and communications systems, tank units can reorganize, reorient, and continue the attack on a reduced timeline.

Pursuit

Pursuit requires broad decentralized control and rapid movement; therefore, the speed and shock effect of a tank unit greatly improves the impact and effect of a pursuit. Direct pressure against the

retreating forces can be combined with an enveloping or encircling maneuver to place troops across the enemy's lines of retreat. Tanks are usually assigned as the enveloping or encircling force as they are less vulnerable to enemy counterattack, an important consideration in any type of pursuit. Tanks are suitable for providing a direct pressure force due to their shock effect and accurate, long-range direct fires.

Forms of Maneuver

Maneuver is the employment of forces on the battlefield through movement in combination with fire (or fire potential) to achieve a position of advantage with respect to the enemy in order to accomplish the mission. The basic forms of maneuver are frontal attack, envelopment, flanking attack, penetration, and infiltration.

Frontal Attack

A frontal attack is an offensive maneuver in which the main action is directed against the front of the enemy force. It is the least desirable form of maneuver for a tank unit because it attacks the enemy's strength and does not take full advantage of a tank's ability to maneuver. The advantages of a tank unit conducting a frontal attack include the following:

- Greater combat power than only infantry forces.
- Inherent speed reduces exposure time to enemy fire.
- Vehicle armor reduces the effects of enemy direct/indirect fires.

Envelopment

Envelopment is the most desirable form of maneuver for a tank unit because it has the required ground mobility to rapidly bypass enemy principal defensive positions and secure deep objectives, ultimately destroying the enemy's cohesion. A tank unit conducting an envelopment possesses greater speed, which is necessary to surprise the enemy from an unexpected direction.

Flanking Attack

A flanking attack is an offensive maneuver that normally directs the main effort to the right or left flank of an enemy formation. This form of maneuver is generally conducted on a shallow axis. A tank unit can capitalize on ground mobility and speed to rapidly maneuver to the enemy flank.

In armor tactics, an envelopment or flanking attack normally requires a base fire element and a bounding element. As the maneuver element, the tank provides mobility, survivability, and a stabilized weapons platform in the attack, which allows the placement of accurate fires from a support by fire position.

Penetration

A penetration maneuver's main effort overwhelmingly concentrates superior combat power deep into a narrow front. Because tanks can maneuver quickly and mass overwhelming fires, they are well suited to perform this type of offensive maneuver. Historically, tank units have been called upon to conduct penetration operations and have done so with great success. A penetration maximizes all of the tank's offensive capabilities and the ability of a tank battalion to conduct numerous simultaneous operations.

Infiltration

Infiltrations normally take advantage of limited visibility, rough terrain, or unoccupied/unobserved areas. These conditions often allow undetected movement of small elements when the movement of the entire force would present greater risks. Infiltration routes must be reconnoitered to minimize the chance that the enemy can observe or hear tank units moving; therefore, it is difficult for tank units to perform infiltrations due to noise, dust signatures, and the large number of vehicles usually found in mechanized units. With proper preparation and planning, tank units can prove successful in adding combat power to an infiltration force.

Defensive Operations

In area or mobile defense operations, tank units are employed to take maximum advantage of their inherent speed, mobility, armor-protected firepower, and shock effect. Tank units are ideally suited to conducting spoiling attacks and counterattacks, thereby providing offensive action during a defensive battle (see app. D for information on chemical, biological, radiological, and nuclear [CBRN] attacks). They also provide long-range, direct fire capability into engagement areas and have the capability to engage both ground and limited air targets. Finally, the combination of tank units' advanced optics and communications are ideally suited to control MAGTF fire support assets for all defensive operations.

Types of Defensive Operations

Tank units are employed in deliberate and hasty defensive operations. Tank units are also used in the reserve.

Deliberate Defense

Tank employment considerations for deliberate and hasty defensive operations are as follows:

- Tank units need to establish primary, alternate, and supplemental battle positions.
- Engineer assets should be prioritized in order to maximize survivability of the tank. Figure 2-1 depicts the three types of defensive tank positions—hull-defilade, turret-defilade, and hide position—from most exposed to least exposed. The hide positions will take more time to dig than hull-defilade positions. The FST position should allow for maximum observation of the unit's sector of fire. The FTL on the tank enables the generation of a 10-digit grid, range, and direction up to 8 kilometers, making FST procedures far more responsive and efficient.
- On board optics allow a tank to observe the enemy and cover obstacles at extended ranges and during limited visibility.

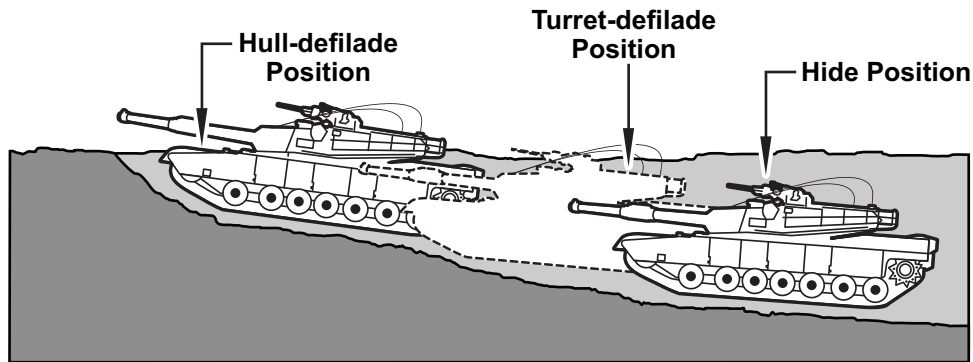

Berms attract attention. Dig down, not up.

Do not put spoil to the front, sides, or rear of the firing position. Reduce spoil so that it blends into existing terrain.

Tie down all antennas and keep reflective surfaces covered.

Make sure the firing position has a covered exit route and a covered route to the next firing position.

Construct overhead cover and add camouflage to create a hide position if time and materials are available.

Figure 2-1. Correct Hull-defilade, Turret-defilade, and Hide Defensive Tank Positions.

Hasty Defense

When employing a tank in a hasty defense, planners must consider that a tank—

- Has a limited ability to construct hasty survivability positions with the use of the tank blade.
- Can conduct rapid resupply with organic CSS.
- Can provide armor-protected security while other units prepare hasty positions.

Planning Considerations for Tanks in the Defense

A thorough understanding of the capabilities of the M1A1 and a METT-T and space and logistics available analysis will aid in the employment of tanks in the defense. Some considerations for such employment include tanks' massed armor-protected firepower, maneuver, shock effect, and robust organic sustainability.

Massed Armor-Protected Firepower

Tank units are best employed where maximum effective range and observation can be achieved. Employment in open terrain and dispersed within a larger unit's battlespace while maintaining internal mutual support maximizes the characteristics of the tank.

Maneuver

Restricting a tank unit's ability to move on the battlefield severely hinders the MAGTF commander's ability to project combat power at decisive points; therefore, planners must consider the ability of tank units to move between various battle positions or rapidly transition to offensive operations.

Shock Effect

Tank units begin to produce shock effect through the effective command and control of MAGTF fires prior to direct fire action. As the defensive fight progresses, shock effect is enhanced as the tank unit unleashes massed armor-protected

firepower while continuing to employ MAGTF fires. Such effects deliver an overwhelming physical and psychological impact on an advancing enemy force.

Robust Organic Sustainability

Tank units' internal organic support structure is ideally suited to ensure continued armor support in defensive operations. Their robust organic capability lends itself to self-sufficiency through armor-protected recovery assets, more secure lines of communication, task organization of battalion CSS, and the ability to transport and deliver large quantities of fuel and ammunition.

Defensive Methods

Tank units can defend in sector, in a perimeter defense, in a linear defense, or from a strongpoint. Regardless of the defensive mission, tanks must carefully choose their positions to properly engage using engagement areas to defeat the enemy.

Sector Defense

Considerations for assigning a tank unit to a sector defense include the following:

- In open terrain, tanks are capable of defending a larger sector due to enhanced communication, optics, and standoff capabilities.
- Infantry units can be attached to enhance security, especially in restricted terrain.
- Lines of communication are less secure.
- The tank unit's ability to control MAGTF fires for the supported commander is degraded.

Perimeter and Linear Defense

Considerations for assigning a tank unit to a perimeter or linear defense are its—

- Ability to mutually support and observe at extended ranges.
- Ability to concentrate direct and indirect fires into the engagement area.

Strongpoint Defense

Considerations for assigning a tank unit to a strongpoint are—

- Integration of infantry.
- Extensive engineer assets required.
- Significant CSS requirement.

Other Tactical Operations in the Defense

Tank units are capable of conducting other tactical operations, including relief in place, screen, withdraw, or reserve in support of defensive operations. The planning considerations for each operation are discussed in the following sub-paragraphs.

Relief in Place

The following are tank unit planning considerations for conducting a relief in place:

- Additional engineer assets will be required to construct fighting positions.
- Tank liaison officer will be provided, if available.
- Attached units may be required to augment security support.
- Time and space requirements must be identified prior to the passage of lines for rearm and refuel.

Screen

A screen force maintains surveillance for its main body forces. Although not preferred, tank units can conduct screen missions. The tank battalion has the organic capability to conduct screens with the antitank platoon. The preferred method to employ the tank company/platoon in a screen is to attach external infantry support.

Withdraw

A withdrawal is an operation in which a unit in contact disengages from an enemy force in order to prepare for a follow-on mission. With extended observation and engagement capabilities, a tank

unit is well suited to support a withdrawal. The inherent mobility of a tank unit, coupled with armor-protected precision fires and an armor-protected FST, provides the supported commander the ability to trade space for time.

Reserve in Support of Defensive Operations

A tank unit's maneuverability, speed, and firepower enable it to be employed as a defensive reserve. It can rapidly maneuver to reinforce a defensive line and conduct spoiling attacks and counterattacks. Considerations for the employment of tank units as the reserve are—

- Reduced forward projected combat power.
- Requirement for multiple routes to reinforce forward units.
- Time-distance relationship between the reserve's hide position and decisive points.
- Preplanned resupply point.

Stability Operations

Stability operations focus on deterring war, resolving conflict, promoting peace, and supporting civil authorities in response to crises. Tanks are employed in both offensive and defensive missions during stability operations. Task-organized as part of a MAGTF, Marine tank units may be called upon to support a wide range of operations in various political and geographical environments. Because of the large number of resources necessary to deploy, operate, and sustain them, tank units are usually used to execute stability operations activities that take maximum advantage of their inherent capabilities.

Disciplined, well-trained, combat-ready commanders and crewmen can adapt to the specialized demands of stability operations when supported with a detailed ROE, a strong relationship with the supported unit commander, and an understanding of the role of host nation security forces. Flexibility and situational awareness are paramount requirements, especially for unit commanders.

Tank units involved in stability operations emphasize their psychological effects more than the offensive capabilities of the tank. Tanks can be viewed as a positive symbol of power and political resolve, but they can also be viewed negatively if not carefully employed.

Note: In the following discussion of stability operations, the term environment refers to the cultural, political, and military context in which these operations take place as well as to the terrain and weather of the area of operation.

Considerations for using tanks in stability operations include the following:

- Steady state environment produced by stability operations requires continuous maintenance and resupply of tank units in order to maximize their unique capabilities.
- The nature of the mission may limit or restrict the use of the full range of the tank's full offensive capabilities.
- Identification of hostile parties will be more difficult, making security of tanks more difficult. For example, the enemy may conceal anti-tank weapons in large crowds.
- Tanks and other military assets will be used routinely to support noncombat functions, such as the protection of civilian food and fuel convoys.
- The ability of tank units to detect mines/improvised explosive devices is limited, but can be enhanced with external support.
- Tanks can provide mobility/countermobility support through the use of the track width mine plow or tank blade within the urban environment.
- Tank presence can often diffuse and deter enemy engagements and actions.

Force Protection

Force protection is a primary responsibility for every commander involved in stability operations. The armor-protected firepower and mobility of the

tank allow it to be employed in a number of stability operations missions that provide the commander with options that may minimize risk to personnel, equipment, and supplies.

Force protection training should include operational security, physical security, and personal security measures to protect tanks and their crews. Tanks can be viewed by the enemy as powerful symbolic targets if they are able to destroy/injure them. Commanders must protect armored vehicles and secure locations for eating, resting, and conducting maintenance, while providing adequate force protection measures.

Public Affairs and the Media

In many stability operations environments, the local populace may view the presence of tank units as a highly visible and potentially intimidating military presence; therefore, the employment of tanks implies a commitment and demonstration of American resolve in the respective crisis and often draws media attention. Consequently, the tank crew's actions may be highly visible, scrutinized, and questioned by the media (see Marine Corps Warfighting Publication [MCWP] 3-33.3, *Marine Corps Public Affairs*, for specific information to deal with the media).

Counterinsurgency Operations

Tank units involved in counterinsurgency operations have roles similar to those involved in other stability operations. The application of stability operations considerations is the responsibility of the supported commander to enhance his/her overall counterinsurgency effort.

Noncombatant Evacuation Operations

The tank unit in stability operations can be used in a noncombatant evacuation operation scenario as an element of a security force or reaction force.

Security

The tank unit can establish a battle position or conduct a relief in place of a battle position as part of a MAGTF perimeter or strongpoint defense (see chap. 2). Dismounted infantry may or may not be integrated with the tank unit. Coordination with dismounted patrols and observation posts outside the perimeter is critical for situational awareness (see chap. 3). In restricted terrain, commanders must understand that, with each application of a tank in a static position, the danger and vulnerabilities of that tank are maximized. A team of four Marines is optimum to provide security for a tank in a defensive or overwatch position. The tank commander should be responsible for the team and their emplacement. In open terrain, such a team may not be required.

Evacuation Route Clearance

Based on METT-T factors, the tank unit may provide overwatch for the route clearance team. If mines and/or improvised explosive devices are detected, the tank unit may conduct hasty breach operations or bypass within its capability. Whenever possible, the unit should be equipped with a track width mine plow or tank blade (see app. E).

Other Tactical Operations

Tank units can be tasked with conducting tactical operations that are not specific to offensive or defensive missions, including security operations, river crossings, and forming an assembly area.

Security Operations

When tanks are employed as a security force, they are usually augmented with other forces that help provide intelligence and quick analysis to develop the situation as quickly as possible once contact is made. Tank units usually focus on avenues of approach large enough for enemy mechanized units to use. Enemy mechanized units pose the largest threat to a mechanized main force.

To help tank units conduct security operations, aviation assets work in concert with ground security forces to facilitate rapid mission execution. Aviation assets can alert tanks of the approaching enemy and they may also help wear down the enemy forces before engagement with ground security forces.

Tank units conducting security operations must also consider that the enemy may have assets that are employed to detect them. Before the security mission, planners should determine the enemy's ability to employ its air, intelligence, surveillance, and reconnaissance assets; likely enemy locations/routes; enemy surveillance devices; indirect fire capabilities; and both mounted and dismounted antitank platform capabilities.

There are three types of security operations: cover, guard, and screen. Screen was discussed previously in this chapter. Tank units can be a supporting element to a larger force serving a covering force, but this mission is beyond the scope of a tank battalion's capabilities. A tank unit is, however, well suited to meet the requirements of a guard force due to its capabilities as discussed in chapter 1.

Reconnaissance by Fire

Reconnaissance by fire can be accomplished with the tank weapons or by indirect fires. For example, if the unit is operating in restricted terrain, it may prove necessary to reconnoiter a wood line or choke point by fire with machine gun fire (.50 caliber or coaxial) to help identify potentially hidden vehicles and/or disrupt an enemy ambush patrol.

River Crossing

The purpose of a river crossing, whether in the offensive or in a retrograde operation, is to project combat power across a water obstacle in order to accomplish a mission. River crossings require specific procedures for success because the water obstacle prevents normal ground maneuver. A thorough ground supportability assessment should be completed. Though the

armored vehicle-launched bridge (AVLB) will no longer be part of the tank battalion's table of equipment, the battalion can provide long range direct precision fire support to the GCE during river crossing operations.

Note: The AVLB resides within the combat engineer battalion.

Passage of Lines

Tank unit planning considerations for conducting a passage of lines are that they require—

- The identification of multiple routes that will support tanks and other heavy equipment.
- The identification of enemy antitank threats.
- Time and space for rearm and refuel prior to the passage of lines.

Tactical Road March

Tank unit planning considerations for conducting a tactical road march are that—

- Tank units will conduct scheduled short halts to conduct preventive maintenance checks and services.
- Tank units need additional refuel points throughout the route.
- Forward reconnaissance is required to identify bridging load-bearing class, fording sites, obstacles, classification of roads, condition of terrain on flanks of routes, and railroad crossings.

Assembly Area

Tank unit planning considerations for conducting assembly area operations are—

- Identifying semi-level terrain due to maintenance for tracked and wheeled assets, conducting resupply, and adequate fields of fire.
- Finding adequate space to allow dispersion, which is approximately a 3-kilometer diameter for a tank battalion with all organic assets.

Convoy Security Operations

Because of the tank's mobility, firepower, and armor protection, tank units can provide convoy security and close-in protection from direct fire to convoys while they are on the move. Depending on a variety of factors, such as the size of the convoy, escort assets available, and METT-T, convoy escort missions are normally conducted by Marine tank units at the platoon level, either independently or as part of a larger unit's convoy security mission. (See Marine Corps Reference Publication 4-11.3F, *Convoy Operations Handbook*, for detailed tactics, techniques, and procedures.)

Cordon and Search

Tank units can be employed with infantry to conduct a cordon and search mission. During the cordon and search, the tank unit normally occupies overwatch/hasty defensive positions to isolate a search area. Close coordination and communication with the dismounted elements conducting the search is critical. Dismounted forces are also employed in observation posts and patrols to maintain surveillance of dead space and gaps in the cordoned area.

Control Points

A tank unit can overwatch an infantry or military police traffic control point/hasty vehicle control point. The overwatch element must ensure it coordinates with the supported units for local security of the tanks.

Reaction Force

Tank units can be employed as an element of the MAGTF reaction force—sometimes referred to as the quick reaction force—in support of stability operations. As discussed in chapter 3, integration of tanks and infantry optimizes a tank unit's assignment to this mission.

This Page Intentionally Left Blank

CHAPTER 3

EMPLOYMENT WITH INFANTRY

When infantry and tanks move together, the infantry moves either dismounted or mounted. This chapter examines how a tank unit is employed to support the advance of infantry.

Marine tank units rarely fight alone. Typically, they are part of a MAGTF and are task-organized with other MAGTF elements to achieve a combined arms effect. Combined arms integrate the effects of infantry, tank, artillery, and aviation to achieve the greatest possible effect against the enemy. The strengths of various arms complement and offset each other, while the weaknesses and vulnerabilities of each arm are protected and offset by the capabilities of the others.

Mechanized operations are tactical operations designed to maximize the ground mobility, protection, shock action, and firepower of combat vehicles in order to concentrate combat power rapidly against the enemy. Combat power is generated by the massed employment of tanks and by enhancing the mobility of infantry through the use of AAVs and other ground mobility means.

Unrestricted terrain, such as flat countryside, desert, or plains, is conducive to the conduct of mechanized operations that are characterized by the employment of massed armor formations. In such terrain, infantry supports the forward movement of the tank units by providing local security, retaining key terrain, clearing dug-in enemy positions, and enhancing direct fires with organic small arms and antitank fires.

Restrictive terrain, such as urban areas, forests, or jungles, increases the vulnerability of tank

units by reducing the speed, mobility, and firepower advantages of the tank. In such terrain, it is necessary for tanks to work closely with dismounted infantry.

Task Organization

The Marine Corps does not maintain permanent, mechanized infantry units; instead, it maintains well-trained, general-purpose infantry units that are capable of task-organizing to execute various ground combat missions. In Marine mechanized operations, mechanized infantry refers to a task-organized force of Marine infantry mounted in AAVs.

Note: Outside the Marine Corps, mechanized operations used in conjunction with infantry (friendly or enemy) operations traditionally refer to the personnel riding in an armored personnel carrier or infantry fighting vehicle that is organic to infantry units.

A Marine mechanized force is a task-organized, ground combat force of combined arms. It is built around an infantry or tank unit and reinforced with substantial assault amphibian assets. A Marine mechanized force is normally supported by air, artillery, light armor, antitank, engineer, reconnaissance, motor transport, combat support, and CSS units.

Commanders at every level of command determine the best organization for combat, typically by cross-attaching units. Cross-attachment is the temporary exchange of subordinate units with

other units. For example, a tank battalion detaches a tank company that is subsequently attached to an infantry battalion mechanized in AAVs. The infantry battalion mechanized in AAVs detaches a company to the tank battalion to create two battalion-sized task forces. Mechanized forces are task-organized into mechanized task forces at the regimental and battalion levels and company teams at the company level.

Note: The supporting unit will receive its logistic/operational support from the unit it is supporting, which will require coordination with the parent battalions prior to cross-attaching.

Mechanized Task Force

Mechanized task forces are organized as follows:

- A tank-heavy force has more subordinate tanks than infantry units. The headquarters of a tank-heavy task force is usually that of a tank battalion.
- A mechanized-heavy force has more subordinate infantry units mounted in tracked vehicles than subordinate tank units. The headquarters of a mechanized-heavy task force is usually that of an infantry battalion or regiment.
- A balanced task force is organized with an equal number of subordinate tank and infantry units. The headquarters for a balanced task force can be either that of a tank battalion or infantry battalion/regiment.

Company Team

A company team is organized by the cross-attachment of one or more tank platoons and/or mounted or dismounted infantry platoons. Based on METT-T, an infantry or tank battalion commander who is receiving tank or mechanized infantry companies may increase the effectiveness of his/her units by forming company teams. Teams are formed by cross-attaching tank platoons and mechanized infantry platoons and are

organized into tank-heavy, mechanized-heavy, and balanced teams.

The tank company is normally the smallest task-organized mechanized element. The tank platoon is normally the smallest unit that is attached/detached. When tanks are task-organized at the company team level, logistic support is normally obtained from the infantry battalion S-4. If the platoon's parent company is in the vicinity, it may be able to coordinate some assistance through the parent unit. Habitual assignment is the routine task organization of one unit to another. Although it may not always be practical, it is highly desirable for the following reasons:

- Attached units become familiar with the standing operating procedures (SOPs) of the units to which they are attached.
- Teamwork is built between units, which is key to achieving unity of effort.
- Unit commanders joining an attached unit become familiar with unit capabilities.

Coordination

Mechanized operations demand effective coordination between the tank unit and the infantry unit it is supporting. Plans should maximize use of a tank's lethal firepower, enhanced target acquisition (including thermal sights), and effective armor protection capabilities. Planners should also consider the logistic requirements of the tank unit. In addition to understanding a tank's capabilities and limitations, the tank unit leader must also understand the disparate capabilities of the mechanized force. For example, infantry mounted in AAVs have less firepower and armor protection and normally move slower over certain types of terrain than tanks do. Another specific example is that sabot ammunition cannot be fired over the heads or flanks of unprotected infantry because of the danger created by the discarding

sabot petals and the concussion of the main gun (see app. A for M1A1 vehicle capabilities).

Mutual Support

To best exploit the mechanized force's offensive capabilities, tanks and mechanized infantry must work together in pursuit of a common goal. Each element of the mechanized force provides a degree of mutual support to the other element. Tanks support mechanized infantry by—

- Providing mobile armor-protected firepower.
- Destroying hostile weapons by fire and maneuver.
- Clearing paths for dismounted infantry through obstacles.
- Destroying fortified positions with direct fire.
- Supporting dismounted infantry by direct fire.
- Assisting in the consolidation of the objective.
- Breaching structures by dynamic or mechanical breaching.

Mechanized infantry assists tanks and AAVs by—

- Clearing the objective.
- Breaching or removing antiarmor obstacles.
- Designating targets for tanks and AAVs.
- Protecting tanks and AAVs from enemy infantry and antiarmor weapons.
- Clearing bridges and fording areas.
- Clearing restrictive terrain.
- Conducting dismounted security patrols.

Employment Methods

There are two general methods to employ tanks and mechanized infantry in an attack:

- Tanks and mechanized infantry, either mounted in AAVs or dismounted, attack together.
- The tanks and AAVs support by fire only.

Though METT-T and space and logistics available will ultimately drive the employment method, both methods provide the commander with the ability to take advantage of different platform capabilities during the attack.

Tanks and Mechanized Infantry Attack Together

This method of attack allows tanks and mechanized infantry to advance together within mutually supporting distances of each other, with tanks normally leading the formation. Ideally, the infantry remains mounted in AAVs to close with the enemy. The advantages of tanks and infantry attacking together are that they—

- Exploit the complete mobility, speed, armor-protected firepower, and shock action of the mechanized force.
- Reduce enemy reaction time.
- Disorganize the enemy's defense, since its positions have been breached before the infantry dismounts.
- Conserve the energy of the mechanized infantry since they are carried by AAVs to dismount points short of, on, or behind the objective.
- Reduce the amount of time that the infantry is exposed to enemy fires.

The disadvantages of tanks and infantry attacking together are that—

- AAVs with light armor protection are vulnerable to antiarmor weapons and may be destroyed if employed like a tank. Such armor can protect against hand grenades, shell fragments, and some small-arms fire; however, even when enhanced appliqué armor kits are installed, the AAV is vulnerable to the fires of tank and antitank guns, antitank guided missiles, and rockets.
- The entire mechanized force can become vulnerable to enemy fires if obstacles are not breached quickly or bypassed.
- There is an increased risk of friendly fire.

Tanks and Amphibious Assault Vehicle Support by Fire

Using tanks and AAVs in a support by fire role maximizes the long-range direct fire capabilities of these platforms to fix, suppress, or destroy the enemy on the objective in support of the dismounted maneuver element. The following are examples of situations in which the infantry should plan to dismount from the AAVs and use the tanks and AAVs support by fire method:

- When obstacles prevent mounted movement and cannot be quickly breached or bypassed.
- When enemy antiarmor capability poses significant threat to both tanks and AAVs.
- When terrain canalizes mounted movement into likely enemy ambush sites and minefields, such as close terrain (urban or woodland) and restrictive terrain (defiles).

Key considerations are—

- Prior planning should be completed to ensure communications can be maintained between the support by fire element(s) and dismounted infantry during the attack. For example, commanders should consider prepositioned retransmission sites and preplanned radio relay procedures that can overcome a potential loss of communications during the attack.
- The scheme of maneuver and fire support plan (direct fire, indirect fire, and aviation-delivered fires) are developed concurrently and understood by all elements of the mechanized force. Fires are primarily used to engage targets on the objective. Fires are also planned to isolate the objective by engaging targets on adjacent positions or likely enemy avenues of approach. Illumination and obscuration fires are planned, regardless of the mechanized force's intent to employ these fires in the attack.
- Positive control of supporting fires between the dismounted infantry and support by fire

element(s) must be maintained throughout the attack.

- Radio communications, prearranged visual signals (such as pyrotechnic), and/or messengers are used by the infantry to designate targets and coordinate supporting fires.
- AAVs, tanks, and other available direct fire support assets normally displace forward to new support by fire positions as they become available.
- Due to the high ammunition capacity inherent in these platforms, a sustained, heavy volume of fires helps the dismounted infantry maintain the momentum of the attack. Suppressive fire helps compensate for the infantry's lack of armor protection and decreased mobility. Long-range accurate fires are employed against enemy vehicles, protected antitank guns and antitank guided missiles, and other priority hard targets.
- Ideally, the support by fire element supports from covered and concealed positions. Units comprising the support by fire element should regularly reposition themselves to avoid presenting the enemy with easily acquired stationary targets. The stabilized weapons platform offered by the tank allows it to continually provide supporting fires when repositioning the support by fire position.
- Dismounted infantry advances on a route that provides cover and concealment and prevents or minimizes masking of the fires of the support by fire element. If available, engineers accompany the dismounted infantry to breach obstacles and destroy fortified positions.

A disadvantage of the tanks and AAVs support by fire only method is that the infantry loses the mobility, shock effect, and close support of the tanks and AAVs. The infantry is unsupported on the objective when tanks and AAVs shift or cease fires. Also, tanks and AAVs are not initially available on the objective to cover the consolidation.

Maneuver Considerations

The critical decision of whether the infantry attacks mounted or dismounted is based on the following considerations:

- Tanks lead and infantry is mounted when—
 - ◆ Enemy antiarmor fires can be effectively bypassed or suppressed by fire.
 - ◆ Terrain is relatively open or manmade and natural obstacles can be easily overcome.
 - ◆ Terrain and weather afford good trafficability and visibility.
- Infantry leads dismounted when—
 - ◆ Terrain and vegetation are restrictive. For example, when terrain and vegetation canalizes movement into likely enemy ambush sites and minefields, such as urban areas and woodland terrain.
 - ◆ Visibility is limited.
 - ◆ Antiarmor fire cannot be bypassed or suppressed by fire.
 - ◆ Significant obstacles or fortified positions are encountered that may prevent mounted movement and cannot be bypassed.

Dismounting

Ideally, the infantry is dismounted after forward defensive positions have been breached and fire superiority has been achieved. The following are some dismount point considerations:

- When the infantry dismounts, personnel must update the tank units on the new location.
- The dismount point should provide good cover and concealment, yet be as near to the objective as possible to reduce the amount of time that the dismounted infantry is exposed to fires while closing with the enemy.

- Rapid dismount and good vehicle dispersion reduces the mechanized force's vulnerability to enemy fires.
- Dismount points may be short of the objective, on the objective, or after passing through the objective.

Note: The decision to dismount must be made prior to committing the force to the final assault.

Dismount Short of the Objective

Tactical conditions may require seeking a dismount point short of the objective. Infantry dismounted short of the objective is usually not within range of small arms and handheld antiarmor weapons. Ideally, the dismount point should be located on easily recognizable terrain that provides cover from enemy direct fires. Considerations regarding tanks when the infantry dismounts short of the objective include the following—

- Control can be established in the dismount point.
- Organic and supporting fires can suppress the enemy while the infantry is dismounting.
- Longer suppression is required.

Dismount on the Objective

Dismount on the objective is a technique used when the mechanized force has achieved surprise or when the enemy's antiarmor defense is weak. Considerations regarding tanks when the infantry dismounts on the objective include the following:

- Supporting fires can continue while the mechanized force approaches its objective, since mounted infantry has greater protection against shell fragments and other small projectiles.
- AAVs are vulnerable to short-range antiarmor weapons.
- Tanks are able to close on the objective with advancing infantry.

Dismount After Passing Through the Objective

Dismounting after passing through the objective is employed when a mounted attack is more effective. The capabilities of the enemy antiarmor defense dictate whether this method is feasible. Considerations regarding tanks when the infantry dismounts through the objective include the following:

- Shock effect on the enemy caused by a mechanized force moving through its position is likely to be considerable.
- The objective is more rapidly isolated from supporting reinforcement.
- The abilities of the tanks and AAVs to provide supporting fires are limited.

Consolidation and Reorganization

The mechanized force consolidates and reorganizes as soon as it takes the objective, so the force can either repel a counterattack or continue the attack. The mechanized force consolidates the objective in the following ways:

- Tanks and AAVs are positioned in hasty defense and assigned sectors of fire while antiarmor weapons are being positioned. Tanks and

AAVs are normally positioned on terrain that provides cover and concealment and permits the vehicles to overwatch the infantry in the event of enemy counterattack. If possible, tanks and AAVs are placed in hull-down positions.

- All elements of the mechanized force establish local security and mutual support between units.
- The dismounted infantry eliminates any remaining pockets of enemy resistance and secures prisoners of war. Dismounted infantry normally designates targets for the overwatching vehicles and uses organic and supporting fires to destroy any enemy resistance.
- After consolidation, the infantry either remounts the AAVs to continue the attack or sets up a hasty or deliberate defense.

Transporting Infantry

On very rare occasions, the platoon commander may be required to transport infantrymen on tanks, which occurs only when contact is not expected. If the platoon is moving as part of a larger force and is tasked to provide security, the lead section or element should not carry infantry. Infantry small unit leader should consult the tank commander on troop positioning on tank (see fig. 3-1).

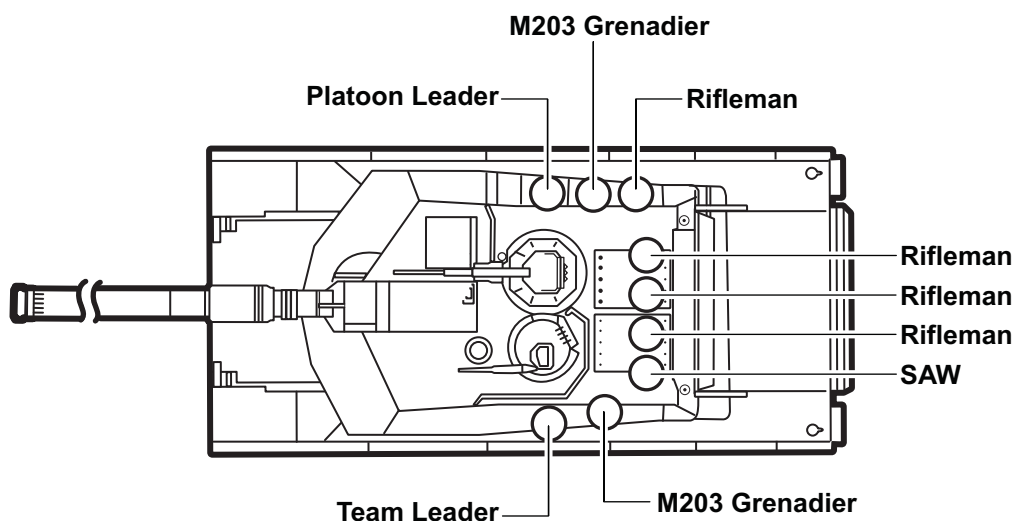

Figure 3-1. Notional Positions for Infantry Riding on a Tank.

CHAPTER 4

TACTICAL LOGISTICS

During operations and training, tank units typically consume tremendous amounts of resources; therefore, it is imperative that thorough logistic planning be conducted in order to sustain them. The tank battalion is capable of self-administration, organic supply support, food service support, and medical services that provide routine and emergency medical care. The battalion has significant, organic logistic capabilities for short-term self-sufficiency, but it requires extensive CSS—especially fuel and ammunition—for sustained operations with a MAGTF.

Trains

A train is a means of internally task-organizing and employing the organic CSS assets of the tactical unit. To increase responsiveness of CSS assets, the tank battalion will often task-organize and echelon its CSS assets into company trains, combat trains, and field trains. Task organization of the trains provides immediate responsive support, flexibility in usage, and an increase in the survivability of assets. The S-4 ensures control and mission assignment throughout the battalion trains. The company tank leader serves as the tank company's primary logistic coordinator. The tank leader also maintains control and directs the operation of company trains.

Company Trains

Company trains are task organized from the field trains to ensure Class I, III, and V items are provided to the tank company. In addition to company trains, the company has an organic maintenance section with tank retrievers that remains in the support of the company at all times.

Combat Trains

Combat trains are organic elements that provide critical CSS in forward areas and are tailored for the tactical situation. They normally contain petroleum, oils, and lubricants; ammunition and other ordnance items; maintenance contact teams with recovery and limited repair capability; and medical support, to include the battalion aid station.

Field Trains

Field trains consist of the remaining organic and attached CSS elements that are located farther to the rear and provide the logistic link between the battalion combat trains and higher MAGTF CSS units.

Organic Capabilities

The nature of mechanized warfare demands that tank units maintain some self-sufficiency. In order to maximize the tank unit's organic logistic capabilities, the unit must identify critical requirements, enhance its organic logistics through other sources when possible, and ensure its logistics are safeguarded.

Identify Critical Requirements

Due to the high tempo and uncertainty associated with armored warfare, the Class IX (repair parts) block items should be reviewed by the tank unit commander or his/her representative to identify any combat deadlining components that may be overlooked. Many logistic requirements cannot be predicted with satisfactory accuracy and, although high-use repair items can be identified and stockpiled prior to a deliberate operation, the logistics

combat element of the MAGTF should build and maintain a Class IX repair parts block based on empirical data and the unique historical knowledge retained by a tank battalion's CSS elements.

Safeguard Resources

In order to ensure continued operation of a tank unit, the trains have the following requirements:

- Echelon to provide logistic responsiveness.
- Plan resupply routes and consider time and distance of travel in order to support responsive resupply.
- Plan resupply, unit maintenance collection, and ambulance exchange points to ensure timeliness and responsiveness.

External Support

Because tanks require such a large degree of logistics, they will usually have to coordinate with Marine Corps and other US and coalition forces if operations are lengthy. To ensure that tank logistic operations are carried out correctly with these forces, requirements must be prioritized, resupply must be responsive, and key personnel should be collocated. Prior coordination between the supporting and supported units for all logistic requirements will best ensure continued armored support is provided to the MAGTF.

Prioritize Requirements

Resupply requests must be prioritized. The establishment of priorities and the allocation of resources in accordance with those priorities is a function of command, not logistics. The priorities are determined by the commander.

Respond Rapidly

Anticipated future resupply that is not identified as preplanned support must be prepared for immediate shipment. Resupply items identified

but not carried by the maneuver forces should be packaged for rapid resupply.

Resupply Operations

The robust organic logistic capabilities of a tank battalion allow the battalion to conduct all three methods of resupply. The situation dictates when and how to resupply.

Resupply Methods

The Marine tank unit uses three methods while conducting supply operations—prepositioning, routine resupply, and emergency resupply. The method used is determined after an analysis of METT-T factors.

Prepositioning

Prepositioning of supplies may be required in some defensive operations. Normally, only Class V items are prepositioned, but Class I and Class III supplies may be included. The location and number of prepositioned assets must be carefully planned and then verified through reconnaissance and rehearsals. Each tank commander must be informed of prepositioning locations. The following considerations influence the selection of prepositioned sites and execution of the resupply operation:

- Availability of overhead cover for the prestock location.
- Cover and concealment of the location and routes used by vehicles.
- Security procedures required to safeguard the resupply operation.
- Procedures for protecting friendly personnel and vehicles in the event prestocked ammunition is ignited.

There are several techniques for accomplishing prepositioned resupply in the defense. Normally,

Class V is positioned next to or within a vehicle's fighting position, enabling the tank crew to resupply during an engagement without displacing. Another technique is to locate Class V supplies en route to or within a subsequent battle position. This method requires security procedures to safeguard the prepositioned assets. Resupply of Class III items (specifically fuel) is usually accomplished behind a unit's current battle position or en route to a subsequent battle position. In the defense, the tank unit may rotate vehicles or sections through prestock positions based on the enemy situation and shortages within the unit.

Routine Resupply

Routine resupply operations include regular resupply of items in Classes I, III, V, and IX and of any other items requested by the tank unit. Routine resupply is planned at the battalion level and occurs whenever possible. The company logistic package is a mixture of company and battalion assets that transport supplies to the company. Logistic packages are normally assembled in the battalion field trains area under the supervision of the S-4 and the tank company commander or their designated representatives.

Emergency Resupply

Emergency resupply, normally involving Classes III and V items, is executed when the tank unit has such an urgent need for resupply that it cannot wait for the routine logistic package. Emergency resupply procedures start with immediate redistribution of ammunition in individual vehicles and are followed by cross-leveling of ammunition. Once requested through the commander, executive officer, or tank leader, the battalion brings emergency supplies forward. The tank unit may have to conduct resupply while in contact with the enemy. To resupply the unit in contact—

- Limited supplies are brought forward to the closest concealed position, where the tailgate technique of resupply is used.

- Individual vehicles or sections disengage and move to a resupply point, obtain their supplies, and then return to the fight. This process is a version of the service station technique.

Resupply Techniques

The tactical situation dictates which technique of resupply the tank unit will use: tailgate resupply, service station resupply, or combination resupply.

Tailgate Resupply

When using the tailgate technique, the tank leader or his/her assistant bring fuel and ammunition to individual tanks (see fig. 4-1 on page 4-4). This technique is used when routes leading to vehicle positions are available and the unit is not under direct enemy observation and fire. It is time-consuming, but it is useful in maintaining stealth during defensive missions because tanks do not have to move.

Service Station Resupply

The service station technique requires tanks to move to a centrally located point for rearming and refueling, either by section or as an entire platoon (see fig. 4-2 on page 4-5). Service station resupply is inherently faster than tailgate resupply because vehicles must move and concentrate; however, it can create security problems. During defensive missions, the platoon must be careful not to compromise the location of fighting positions. A company being resupplied using this technique can maintain security by having only one platoon move at a time; a platoon can do the same by moving one section at a time to the resupply point.

Combination Resupply

A platoon commander can use the two basic techniques in combination. For example, during a defensive mission, a platoon commander may use the tailgate technique for a mounted forward observation post and the service station method

for the remainder of the platoon located in hide positions (see fig. 4-3 on page 4-6).

Maintenance Operations

Tank units recover and repair damaged assets as far forward as possible. If equipment cannot be repaired onsite within two hours (METT-T dependent), it is moved to a unit maintenance collection

point. The robust organic maintenance and recovery capability of a tank battalion includes—

- Heavy equipment recovery and maintenance (both tracked and wheeled).
- Engineer equipment maintenance and limited repair.
- Ordnance and optics maintenance and repair.
- Tactical communications maintenance and repair.

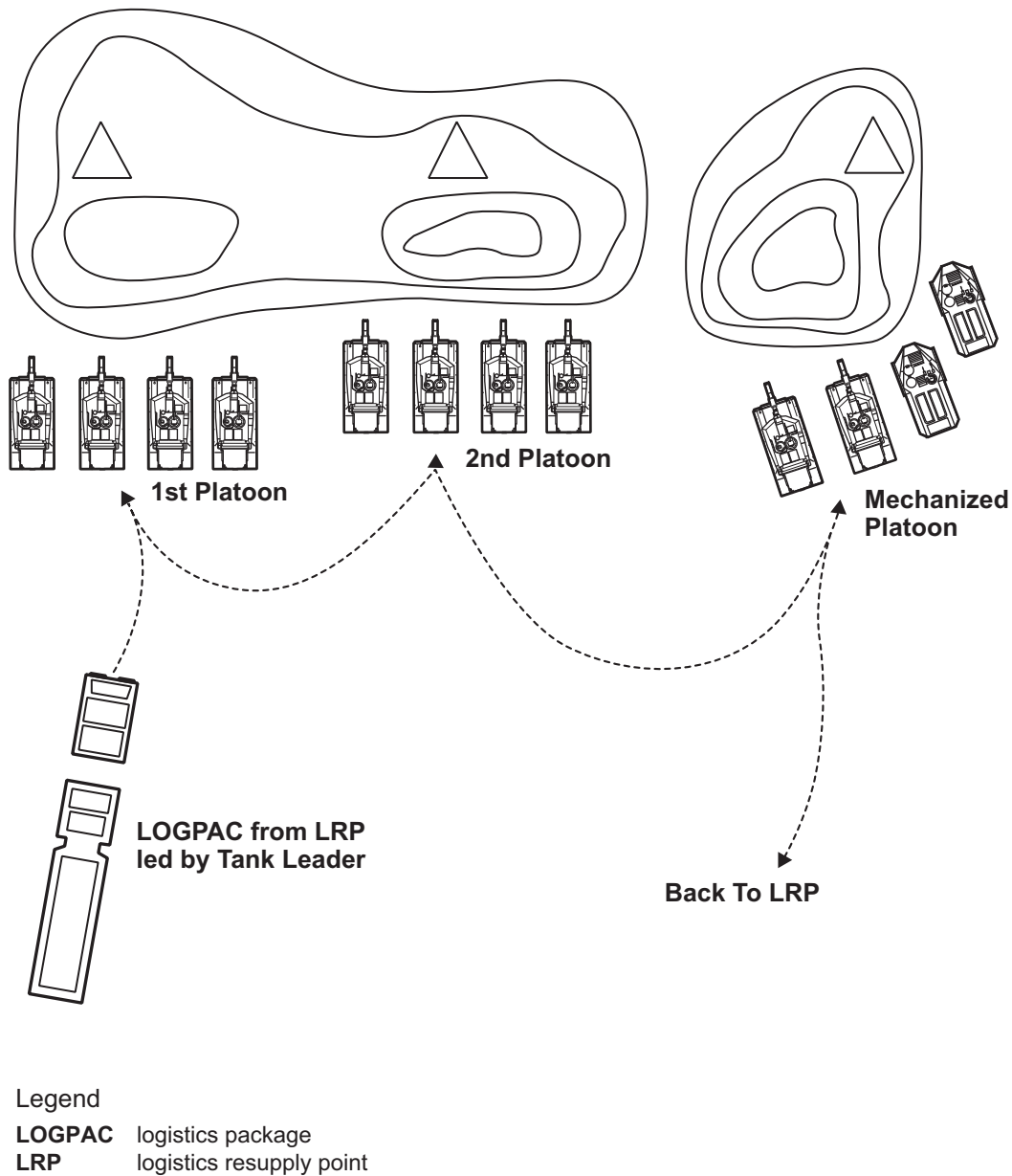
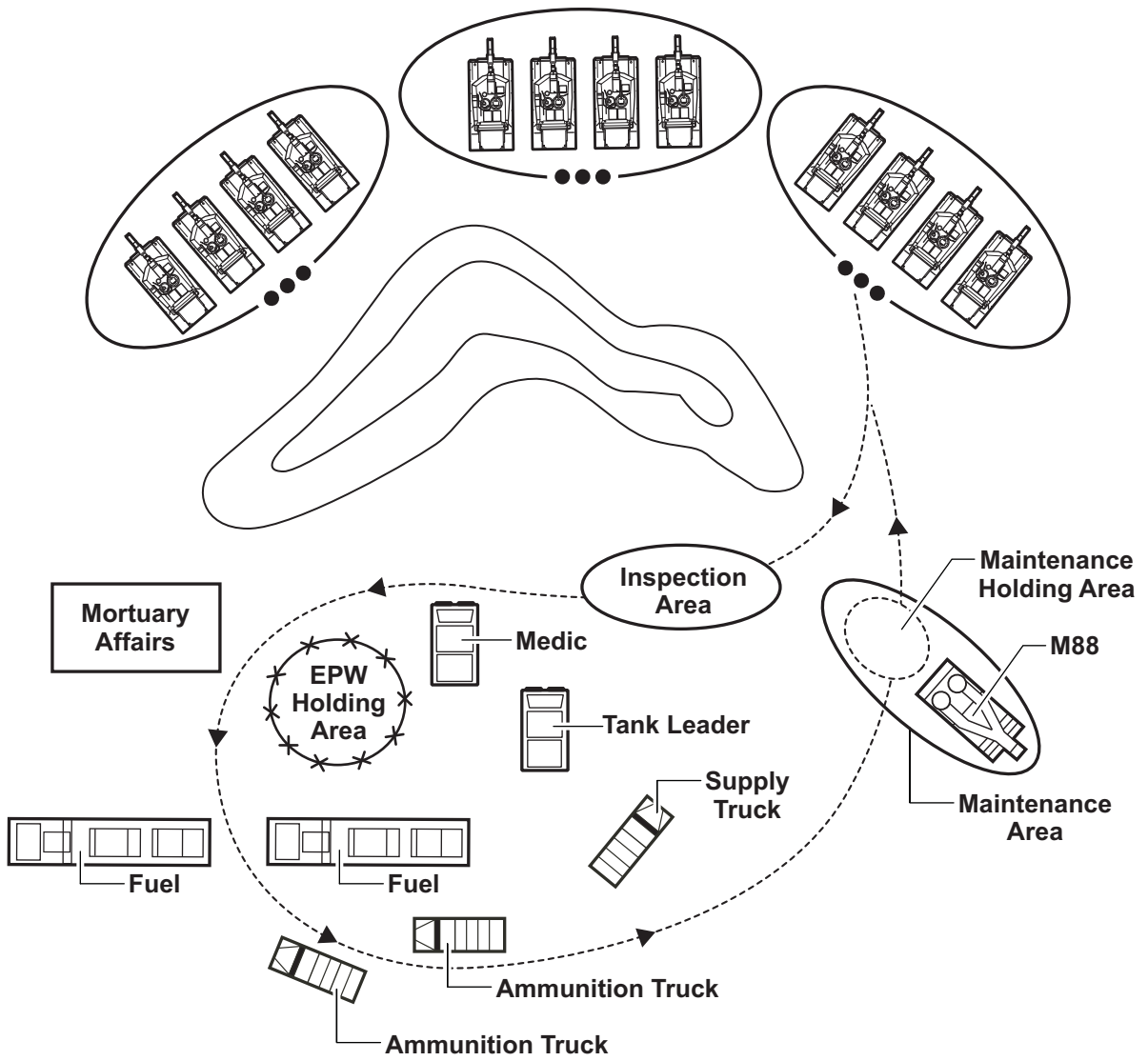

Figure 4-1. Tailgate Resupply Technique.



Legend

EPW enemy prisoner of war

Figure 4-2. Service Station Resupply Technique.

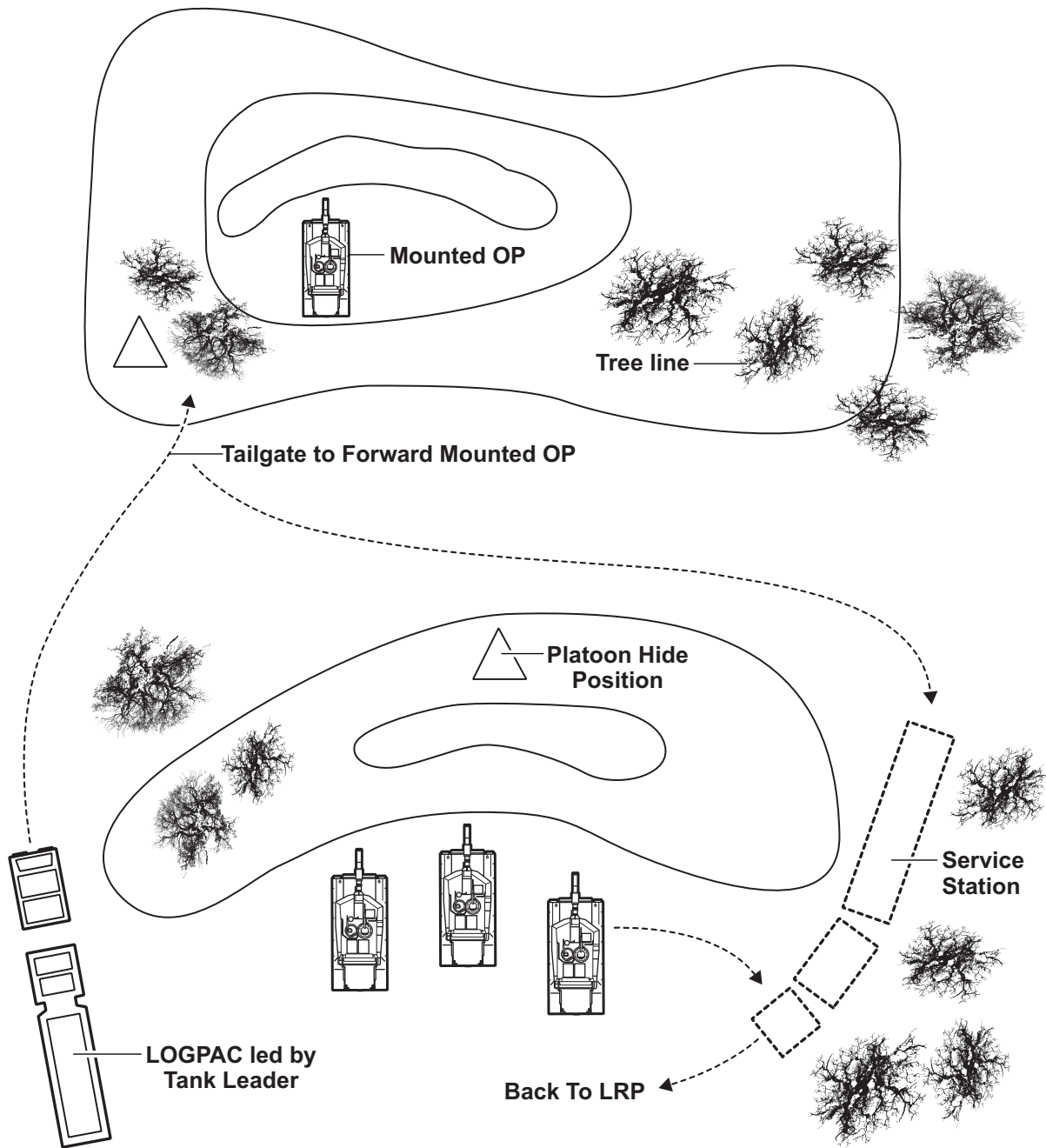

Legend

- LOGPAC** logistics package
- LRP** logistics resupply point
- OP** observation post

Figure 4-3. Example Combination of Resupply Technique.

CHAPTER 5

AMPHIBIOUS OPERATIONS

There are four types of amphibious operations, each designed to have a specific impact on the adversary: amphibious assault, raid, demonstration, and withdrawal. Planning for the employment of tanks during the four types of amphibious operations differs little from planning for tank operations ashore. The operation plan provides basic information for a buildup of tanks ashore and their initial employment as well as the logistic support necessary in combat operations ashore. Amphibious planning for tanks is conducted concurrently and in coordination with the planning of other units of the landing force.

Planning Considerations

Tank unit representation needs to be integrated with the planning process for all warfighting functions. The MAGTF planners should consider the following points pertaining to tank employment:

- Mission and concept of operations of the landing force.
- Enemy situation, particularly the enemy anti-tank defenses.
- Terrain, weather, and beach conditions.
- Shipping and landing craft availability.
- Tank strength available to the landing force.
- Rapid establishment of CSS capability ashore.
- Recovery of fording kit exhaust stacks (coordinated through the beachmaster).

Embarkation Plan

Upon receipt of the shipping allocation, the tank battalion begins planning. A listing of personnel and equipment to be assigned to each ship is

created. During embarkation planning, it is determined whether tanks will be preboated prior to completing the embarkation plan. Final embarkation plans are developed after studying the assigned ships' characteristics pamphlets and directly communicating with the ships' officers. If required, time and space onboard each ship must be allotted in order to prepare for the mounting of fording and other mission-specific equipment.

Landing Plan

When subordinate units of the tank battalion are attached to infantry units, their plan for landing is reflected in the landing document of the units they are supporting.

Note: Tank units do not conduct stern gate marry transfer.

Intelligence Requirements

The timely and continuous receipt of intelligence is critical to the employment of tanks. Intelligence for the employment of tanks during an amphibious operation should focus on what and where enemy antitank systems could be employed and the enemy's most likely course of action to stop tanks from coming ashore and moving inland.

Terrain

Tank intelligence requires terrain information on beaches and terrain inland from the beaches. Required information about the beaches includes—

- Location, length, width, gradient, and composition of the beach and land adjacent to the beach.
- Trafficability of the land.

- Existing and reinforcing tank obstacles on and adjacent to the beach.
- Suitable exits.
- Sea approaches, including underwater gradient and offshore obstacles.
- Surf, tide, and current conditions.

Weather

Weather affects surf/sea conditions, which are critical to the use of landing craft and landing ships attempting to place tanks on the shore. Winds and visibility influence control and coordination of tank units during landing. Rough seas have an adverse effect on the offloading of tanks. Precipitation affects not only visibility, but also trafficability. Extremes in temperature give added importance to the logistic requirement.

Enemy Situation

The following information is important to tank unit planning:

- Beach antitank defenses.
- Enemy's overall countermechanized capability, including location of enemy armored units and reaction time against the landing force.
- Enemy air capability.
- Enemy electronic warfare capability.
- Enemy CBRN capabilities.

Embarkation/Debarkation

Amphibious operations involving Marine Corps tank personnel and assets are limited by movement from ship to shore via landing craft, utility (LCU) or landing craft, air cushion (LCAC). Tanks conducting amphibious operations will be equipped with a fording kit. Additionally, an LCAC can transport only one tank and an LCU can transport two tanks due to landing craft weight restrictions (see Marine Corps Reference Publication 3-31B, *Amphibious Ships and Landing Craft Data Book*).

Environmental Characteristics

Environmental characteristics that affect embarkation/debarkation are—

- Fording depth: 78 inches (2 meters).
- Additional wave action: 12 inches (30.48 centimeters).
- Fording depth capability: maintained on slopes up to 40 percent.
- Crosscurrent: 20 mph (32 kph).
- Sea state: condition 2.
- Water: fresh or salt.

Fording Kit Characteristics

Equipment characteristics that affect embarkation/debarkation are—

- Fording duration: 10 minutes in the water.
- Automotive power performance degradation of M1A1: not more than 30 percent (acceleration and speed).
- Dimensions: length increases no more than 24 inches (60.96 centimeters).
- Weight: weight increase of 350 pounds (159 kilograms).
- Installation or removal: 2 hours with three-person crew.
- M1A1 operating speed: 4 to 6 mph (6 to 10 kph) at 78 inches (2 meters) of water depth.

Embarkation/Debarkation Planning Considerations

Embarkation/debarkation planning considerations for LCUs, LCACs, and tanks with mine plows and blades include the following:

- LCU loads—
 - ◆ When loading two M1A1 tanks, use rear and midship spots and reposition LCU after first tank is offloaded.
 - ◆ Tanks with track-width mine plow or blade must be loaded in the forward spot due to the width of the vehicles.

- ◆ The embarked crewmen gripe down vehicles. It is the LCU craftmaster's decision when to gripe down.
- ◆ When practical, keep LCU loads tank-pure.
- LCAC loads—
 - ◆ One M1A1 can be loaded on an LCAC.
 - ◆ Vehicles are always griped down.
 - ◆ The tank crew rides in the craft's crew compartment.
- Tank with mine plows and blades on LCUs—
 - ◆ The M1A1 with an attached plow or blade must be positioned in the forward spot on an LCU.
 - ◆ The tank must be loaded and offloaded with a negative ramp (ramp angle below horizontal) on the LCU to prevent damage to the LCU.
 - ◆ Dunnage must be placed parallel along the path of the track, under the craft ramp, and perpendicular to the path of the tank with the plow/blade (creating a speed bump). Such placement raises the height of the mine plow/blade, preventing damage to the ship when offloading vehicles from landing craft into the well deck.

Responsibilities

It is the responsibility of the tank commander to determine whether the tank's embarkation/debarcation procedures are safe. The tank commander

must ensure that there is a coordinated effort between the tank crews and Navy personnel. These responsibilities are as follows:

Embarked tank crews must—

- Gripe down.
- Remain on the tank (LCU)/crew compartment (LCAC).
- Ensure that the gun tube does not interfere with movement of the landing craft into or out of the ship.
- Clear foreign objects and damage from the tank before loading during LCAC operations.

The craftmaster must—

- Provide gripes.
- Provide depth soundings along the end of the ramp (3 feet is considered a good ramp) and at the hinge and aft of the wingwall.
- Ground the craft prior to offloading.

The beachmaster must—

- Provide modified surf index and hydrographic survey to craftmaster.
- Salvage grounded equipment.

Coordination of life jackets and dunnage disposal is provided on the ship.

This Page Intentionally Left Blank

CHAPTER 6

MILITARY OPERATIONS ON URBANIZED TERRAIN

The powerful, high-velocity cannon mounted on the M1A1 tank provides Marines with a key requirement—a highly survivable direct-fire asset—for victory in urban areas. Although the infantry assumes the lead role during combat in urban areas, tanks and infantry work as a close team. Tanks move down streets as the infantry provides protection against the antitank threat. Tanks, in turn, support the infantry with fires. The primary role of the tank during combat in urban areas is to provide heavy direct fire against buildings and strongpoints that are identified as targets by the infantry. The quick, accurate, and devastating effects of the 120-mm tank cannon, coaxial 7.62-mm machine gun, and .50 caliber machine gun are major assets to Marines fighting in urban areas.

The tank provides an all-weather, direct-fire platform. Crewmen can use the tank's thermal systems to engage targets in the limited visibility conditions that often accompany urban fighting environments. Precision engagement systems enable forces to locate the objective or target with enhanced optics and engage with desired effect. Even from extended ranges, a tank unit's precision engagement capability provides some force protection for the GCE and can limit collateral damage to noncombatants, such as civilians in buildings adjoining those being engaged, and local infrastructure.

An assault on Fallujah in November 2004 is an example of military operations in an urban environment. During this assault, all but one of the infantry battalions involved had tanks attached. These tank units were attached in the few weeks prior to the operation and the TTP continued to be refined throughout the operation. A tank section would typically be placed in direct support of a company and would lead the way down streets, with infantry clearing adjacent buildings. The

infantry companies dedicated dismounted squads to provide security to each tank section since the tanks were “buttoned up” and had no other means to cover their dead space.

Tank Units and the Infantry

Tanks have been the primary fire and maneuver force on the armor-heavy battlefield and they have played a major role in the full range of military operations. In military operations on urbanized terrain (MOUT), the tank is a valuable support platform for the infantry as a combat multiplier and can provide a tremendous advantage to combined arms forces engaged in urban combat.

Some key considerations for tanks and infantry working together in urban areas are—

- Situational awareness must exist between the tank and the infantry. Crosstalk between tankers and the infantry fosters a good working team. Communication between elements can occur through radio communication; use of the tank infantry phone externally mounted on the right rear fender of the tank; and visual signals, such as hand-and-arm signals and pyrotechnics.
- The use of the M203 grenade launcher and tracer rounds from organic weapons to the infantry are highly effective at gaining positive identification of enemy barriers and fortifications by designating targets for the tank.
- Both the infantry and tankers must exercise tactical patience. Tanks are in a support role and depend on the infantry for support and protection against close ambush.
- Terrain can create mobility restrictions for a tank: terrain that is easily trafficable by the infantry may be impassable by a tank.

- The use of tanks does not negate the need for smoke, obscurants, and indirect fire when moving up to an obstacle and support-by-fire positions.
- It is essential that tankers attached to the infantry unit be involved in every step of operation order development, especially rehearsals.
- To be effective, the tank and infantry units are organized as a combined arms team.

When the mechanized Marine force is employed in an urban area that is very restricted, tank units are most effective when task-organized into sections. Marine tank units support Marine infantry in urban areas by—

- Providing overwhelming firepower and shock effect by using the main gun/machine guns.
- Isolating objectives with direct fire to prevent enemy withdrawal, reinforcement, or counter-attack.
- Suppressing, obscuring, or destroying enemy positions with smoke, high explosive, and automatic weapon fire as infantry closes with and destroys the enemy.
- Assisting opposed entry of infantry into buildings when debris, obstacles, or enemy fire blocks doorways by firing breaching holes into buildings.
- Breaking through street barricades or reducing barricades by fires.
- Using fires to reduce enemy strongpoints in buildings.
- Holding cleared portions of the objective by covering avenues of approach.
- Attacking any other targets designated by the infantry by fire.
- Establishing roadblocks.
- Providing concealment through smoke grenade launchers and cover from small arms fire in linear danger areas.
- Suppressing or destroying identified sniper positions.

Marine infantry facilitates tank employment in urban terrain by—

- Locating targets for engagement by the tank.
- Suppressing and destroying antiarmor weapons with mortars, automatic weapons, and grenades.
- Assaulting positions and clearing buildings.
- Providing local security for tanks.

Planning

Compared with combat in open terrain, urban operations are compressed in space and time. This compression limits observation distances; engagement ranges; weapons effectiveness; mobility; and time to maneuver, generate more fires, anticipate enemy actions, plan and conduct operations, and, if necessary, respond to enemy actions. These limitations tend to force extremely close combat with troops fighting from building to building and from room to room. Command and control is difficult because small-unit leaders cannot see their troops and radio communication is subject to interference caused by the presence of structures. Historically, urban combat has required a high degree of initiative by small-unit leaders who were directing the employment of task-organized special assault teams, of which tanks were a part.

When tanks are to be task-organized for MOUT, it is vital that tank unit representatives be involved with the planning process as early as possible. Marines down to the infantry squad and tank section levels must be familiar with unit SOPs for effective tank-infantry employment in MOUT operations. Additionally, the tank unit leader must keep the infantry commander informed regarding his/her unit's supply, crew, weapons status, and any special equipment available, such as mine plows and rollers.

When planning a mission, commanders must consider the capabilities, limitations, and likely

courses of action available to the enemy. The commander and staff must consider the strength, composition, disposition, and activities of the enemy forces. Enemy tactics may range from ambushes, snipers, and urban terrorism to large-scale conventional operations; therefore, METT-T must be considered by tanks and infantry necessitating different tactics, techniques, and procedures based upon the situation. The addition of armor creates the following planning considerations for the infantry commander:

- Conducting full dress rehearsals, using tanks whenever possible.
- Standardizing reporting formats for both tanks and the infantry.
- Establishing SOPs for tanks working with infantry, emphasizing the safety of friendly infantry maneuvering with tanks, signal plans between tanks and infantry, marking of cleared buildings/areas, ROE, and mutual security between tanks and the infantry.
- Determining tank maintenance and logistic support requirements to the supported unit.
- Considering battle damage assessment and recovery, resupply, and casualty evacuation of tank crew personnel.

Employment Considerations

Marine infantry/tank commanders should consider the following when employing the M1A1 in urban terrain:

- Tank main gun fire is an effective method for eliminating threats in a building or creating a psychological effect that can destroy the enemy's will to continue.
- Streets and alleys constitute ready-made engagement areas that can greatly restrict and canalize vehicular traffic.
- Tanks should be employed by section. All fundamental fire and movement techniques are conducted at the section level, so tanks should never be employed individually.
- Typically, a tank section and an infantry squad support each other. The infantry furnishes local security and designates targets for the tank.
- VHF radios are used for intervehicular communications and should be the primary means of communication between the infantry and the vehicle commander. If VHF radios are unavailable, the tank infantry phone or hand-and-arm signals can be used.
- The infantry commander should communicate with the supporting tank unit to coordinate the effects of fires, to include arming distances of tank main gun ammunition (see app. F).
- Tank main gun ammunition can be used for, but is not limited to, the following:
 - ◆ Obstacle reduction (chemical energy rounds).
 - ◆ Reduction of fortified areas (chemical energy rounds).
 - ◆ Obstacle reduction and destruction of massed infantry (canister rounds).
 - ◆ Dynamic breaching for an assault element (chemical energy and canister rounds).
 - ◆ Countersniper fires.
 - ◆ Reduction of masonry walls (chemical energy rounds are most effective). The sabot round can penetrate deeply into a structure, but it does not create as large a hole or displace as much spall behind the target. In contrast, tank chemical energy rounds are large enough to displace enough spall to inflict casualties inside a building.
 - ◆ Engagement of troops in cover without overhead protection (multipurpose high explosive tank round in air burst mode).
- Tank sabot ammunition has limited utility against most nonvehicular targets and the discarding sabot petals can endanger friendly infantry or civilians nearby. The hazard area extends 70 meters to each side of the gun target line out to 1 kilometer.

- Tanks should avoid stopping or moving slowly near nonsecure buildings due to the threat of possible enemy close range antitank fires.
- Tanks should mount the heat deflector to allow Marine infantry to safely approach the rear of the M1A1 tank without being burned by the tank's exhaust.
- Units should check all bridges and overpasses for mines and determine the bridge's military load classification (MLC).
- When the tank's main gun fires, it creates a large fireball and smoke cloud. In the confines of a built-up area, dirt and masonry dust are also picked up and added to the cloud, so the target is further obscured by the smoke and dust of the explosion. Depending on the conditions, this obscuration could last as long as 2 or 3 minutes. Marines can use this period to reposition or advance unseen by the enemy.
- A tank cannon creates an overpressure that will kill indiscriminately and a noise hazard to exposed Marines. All dismounted Marines working near tanks should wear Kevlar helmets and protective vests, as well as ballistic eye protection while maintaining a standoff of 50 meters from the main gun. If possible, they should also wear earplugs and avoid the tank's frontal 60-degree arc during firing. The overpressure can also cause glass in surrounding buildings to shatter. Falling glass can cause injury to Marines if they are not warned to stay clear of windows.
- Tanks are sometimes at a disadvantage because their main guns cannot depress or elevate sufficiently to fire into basements and upper floors at close range. The M1A1 can depress to -10 degrees or elevate to a height of 20 degrees.
- The M1A1 has a coaxial M240 machine gun to engage enemy troops and enemy positions behind light cover. The coaxial machine gun has the same elevation and depression restrictions as the main gun.
- The commander's weapons station (.50 caliber machine gun) can be independently operated to acquire and engage additional targets during both day and night operations.
- When buttoned up (hatches closed), tank crews have limited visibility. Infantry security for the tank must help the tank crew "see" by relaying to the tank crew possible targets relative to the tank's position and orientation.

The M1A1 tank has limited elevation in an urban environment. Its lower depression limit creates 35 feet of dead space around a tank (see fig. 6-1). There is also a zone overhead in which the tank cannot fire (see fig. 6-2). This dead space offers ideal locations for short-range anti-armor weapons and allows hidden enemy gunners to fire at the tank when the tank cannot fire back. It also exposes the tank's most vulnerable areas: the flanks, rear, and top. Infantry must move alongside and to the rear of tanks to provide close protection. The M1A1 tank also has a

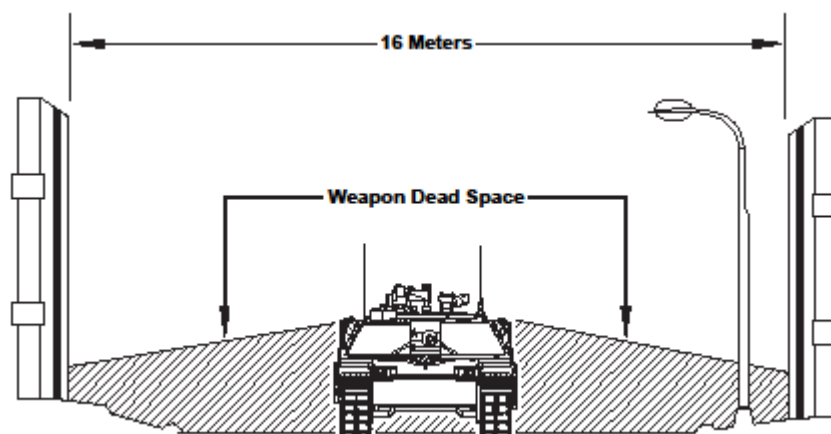

Figure 6-1. Tank Cannon Dead Space at Street Level.

blind spot caused by the 0 degree depression available over part of the back deck. To engage any target in this area, the tank must pivot to convert the rear target to a flank target.

Note: Due to the limited visibility in the urban environment, infantry units, when moving forward, must maintain communication with supporting tank units to prevent injury from friendly fire.

Tanks are equipped with thermal sights, which can be used to detect enemy personnel and weapons hidden in shadows and behind openings. Dust, fires, and thick smoke can degrade this sight capability.

Tanks have turret-mounted grenade launchers that project screening smoke grenades. The grenades use a bursting charge and burning red phosphorous particles to create the screen. Burning particles can easily start uncontrolled fires and are hazardous to dismounted Marines near the tank. The tank commander and the infantry small-unit leader must coordinate when and under what conditions these launchers can be used.

The tank's size and armor can provide dismounted Marines with cover from direct-fire weapons and fragments. With coordination, tanks can provide moving cover for Marines as they advance across small open areas; however, fragmentation generated by antitank rounds that

ricochet off of a tank's armor have caused casualties while infantry were working with tanks in built-up areas.

Control Measures

Combat in urban areas requires control measures with which all troops must be familiar. One of the keys to ensuring ease of coordination of fires, linkup points, and patrol routes is the use of an effective map system. Intelligence sections should provide an accurate map, down to exact buildings if possible. Buildings and roads can be sectioned off and labeled alphanumerically. Without an effective and universally used map, tank operations in MOUT are diminished due to the difficulty in coordinating tank and infantry maneuvers. Tank weapon systems can penetrate structures and, without a common understanding of friendly maneuver, the potential for injury due to friendly fire increases.

Offensive Military Operations on Urbanized Terrain

Because of the nature of the terrain, offensive urban area operations are typically conducted by dismounted infantry. Tanks should be employed

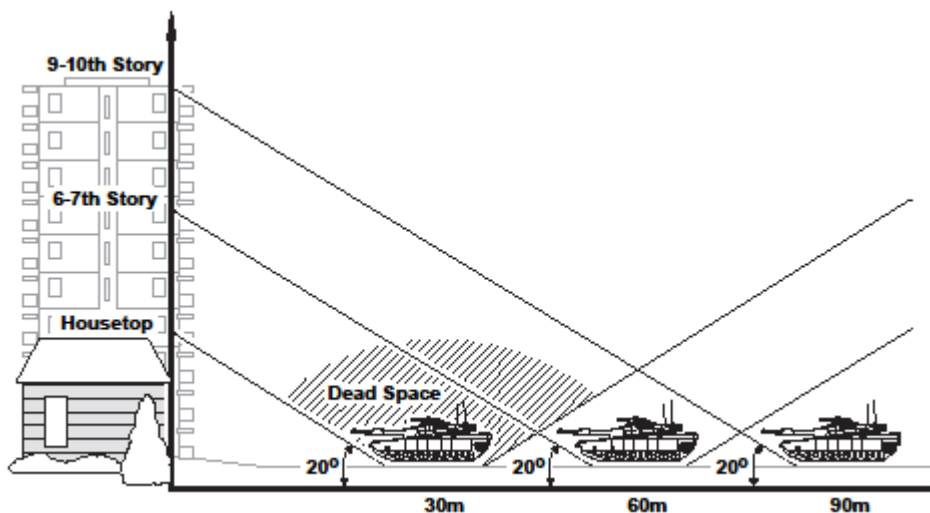

Figure 6-2. Tank Cannon Dead Space Above Street Level.

as much as possible in close support of dismounted infantry in order to secure locations and provide direct fire support. Formations depend on the composition of the combined arms force. The best security formation for command and control is a column. The column must be flexible and provide 360-degree security. The combined arms column travels within this security, with dismounted infantry clearing buildings and providing security along the route. Upon contact with the enemy, the tanks and infantry should coordinate to ensure the proper weapon system is selected to engage. Buildings and terrain will most likely not permit an on-line formation.

Attacking in Urban Areas

A detailed study of the city and the enemy's dispositions in and around it forms the basis for planning the attack and seizure of an urban area. Planning may include tanks for both maneuver and fire support. The attacking force is normally separated into two forces—the enveloping force (tank-heavy) and the direct assault force (infantry-heavy). The following points are considered when attacking in an urban area with tanks:

- Tanks tend to attract the attention of the enemy, causing them to react.
- Tanks allow an attacking force to concentrate overwhelming combat power to force a quick and violent disruption of the defenses, envelop the urban area, and move rapidly to the enemy's rear.
- Tanks will reduce strongpoints, secure them for follow-on forces, and maintain the momentum of the attack.
- Tanks can cut lines of communications and defeat the enemy through isolation.

Tanks need infantry to provide security in built-up areas and to designate targets. If targets are protected by structures, tanks should be escorted forward to the most covered location that provides a clear shot. On-the-spot instructions by infantry commanders ensure that the tank's fire is

accurate and its exposure is limited. The tank commander may have to halt in a covered position, dismount, and reconnoiter his/her forward route into a firing position.

Attack Phases

The coordinated movement of tanks and infantry in concert is key during the attack phase. Prior planning and reconnaissance of routes and objectives will assist in execution; however, flexibility and established SOPs between the tanks and supported infantry will reduce friction if the plan changes. Infantry commanders/leaders and tank commanders should build one another's situational awareness throughout the attack.

Reconnoiter the Objective

Avenues of approach for infantry and the tanks, observation posts, supply routes, and the emplacement positions of direct and indirect fire weapon systems for both tanks and infantry are all examples of information that can be obtained during reconnaissance. The locations of enemy antitank weapons can likely be determined as danger areas for tanks. Composition and structure of buildings and roadbeds, cover and concealment opportunities, and other information not apparent in a map study may have a significant impact on the plan. For example, determining that the buildings that are to be attacked are made of brick means tanks will have an easier time making building breach holes for infantry than if the building walls contained reinforced rebar.

Isolate the Objective

To isolate an urban objective, tanks can be used two ways: to isolate an enemy objective by becoming a support element or to employ as part of the attack. Tanks used as a support element can be held in reserve or given a mission to keep enemy reinforcements from moving into the isolated attack objective, such as a main avenue of approach into a town. When tanks are used in the attack force, they may be employed to directly

support the attacking infantry to help reduce fortified buildings/areas. They can also engage enemy forces trying to hinder the attack.

If tanks are of limited use within a town due to the inability to maneuver, they can be employed just outside the urban area to restrict further enemy forces from entering. The tactics and techniques for this phase of the operation are similar to those used in an attack against an enemy strongpoint.

Secure a Foothold

Once the objective is isolated, a foothold should be secured as soon as possible in order to maintain tempo. Dismounted forces can be employed to attack from any direction. If infantry is working with tanks, then areas above, at, and below the street level (such as cellars, buildings, sewers, or subways) must be cleared as tanks move through the area in order to ensure that enemy antitank teams are not able to move around the attacker and engage the tanks. Both tanks and infantry should ensure that areas are cleared for possible mines/improvised explosive devices. After seizing a foothold, the attacking force continues the attack through the objective area. Normally, the attacking force penetrates the enemy defenses on a narrow front. Tanks can be used to secure avenues of approach along this front and provide further isolation of the objective to the attacking force. The assault is supported by all available supporting arms and usually maximizes use of smoke to screen the attacking forces movement.

The commander may employ variations of the column formation to better maneuver into urban areas. The leading tank elements normally use a formation that speeds the delivery of maximum fire on the point of penetration. When the infantry attacks a strongly defended area, it provides close-in protection for the tanks while the tank reduces the fortification. Unit leaders may assign fire teams or squads to work with each tank. If radios are not available, visual signals and tank infantry phones may help maintain direct

communication between the infantry leaders and the tank commanders. The infantry maneuvers to suppress or destroy the enemy and tanks move forward as soon as possible to support them. Suppressive tank fires can be used to cover the attacking force's exposed flanks.

Seize the Objective

Once a foothold is seized and consolidated, supporting forces move to the built-up area to support the seizing of the objective area. During this phase, tanks can be used for continued direct fire support of the infantry, local isolation of the objective, or follow-on objective isolation. They can also be used for securing beyond the objective or held in reserve.

It is rarely possible to employ more than two tanks at the head of the column, except when advancing on a wide street. Tanks continuously concentrate main gun and automatic weapons fire on windows and the rooftops of buildings. The infantry protects the tank from close-in enemy fire. When required to protect tanks from fire from nearby buildings, an infantry squad moves along each side of the street, keeping abreast of the lead vehicles. Unit leaders will usually assign Marines in each squad to locate and engage targets on the upper floors and rooftops of the buildings. The infantry may also assist in the removal of obstacles or barriers that would halt the advance. Lead tank crews must continually be aware of the infantry's location in order to avoid being injured by friendly fire or moving forward of their infantry security and being engaged by enemy antitank teams.

Defensive Military Operations on Urbanized Terrain

In urban combat, the defender possesses key advantages over the attacker. The defender can shape the battlespace to his/her advantage by maximizing the natural restrictions and obstacles

found in the urban environment. Knowledge of the terrain and time available for preparing defensive positions are advantages that may enable the defender to successfully resist a numerically superior force. Defensive operations in a built-up area require thorough planning and precise execution based on METT-T.

Defensive Planning Considerations

Due to the high consumption of fuel and ammunition, the commander must plan to resupply and conduct maintenance for the supporting tanks during transition to defensive operations in the urban environment. At minimum, tanks must be rotated at the section level to resupply and conduct maintenance.

Defensive Techniques

In the defense, Marine tanks provide the MOUT commander with a mobile force that can respond quickly to enemy threats. They should be located on likely enemy avenues of approach in positions that allow them to take advantage of their long-range fires. Effective positioning allows the commander to employ the armored vehicles in a number of locations, such as the following:

- On the edge of the city in mutually supporting positions.
- On key terrain on the flanks of towns and villages.
- In positions from which they can cover barricades and obstacles by fire.
- As the reserve.

The commander may also employ sections with infantry platoons or squads, allowing the tanks to take advantage of the close security provided by the infantry. In addition, tanks can provide mobility/countermobility support within the urban environment. For example, if counter-mobility is needed, tanks can facilitate the destruction of urban structures to limit enemy avenues of approach. In the case of mobility, tanks equipped with the blade can clear rubble and fill in obstructions.

Fighting Positions

Fighting positions for tanks are an essential component of a complete and effective defensive plan in built-up areas. Vehicle positions must be selected and developed to afford the best possible cover, concealment, observation, and fields of fire; at the same time, they must not restrict the vehicle's ability to move when necessary (see fig. 6-3).

If fields of fire are restricted to the street area, defilade positions should be used to provide cover and to enable tanks to fire directly down the streets. From these positions, the armored vehicles are protected while retaining their ability to rapidly move to alternate positions. The tank crew's vision will be restricted while in defilade. If an infantryman acquires a target, he/she should signal the armored vehicle to move to the firing position and direct the crew to the target (see fig. 6-4). After firing, the tank moves to an alternate position to avoid compromising its location. Infantry are usually employed abreast of the tanks so that they can fire toward the expected direction of attack. Excessive separation between the tanks and infantry does not facilitate mutual support.

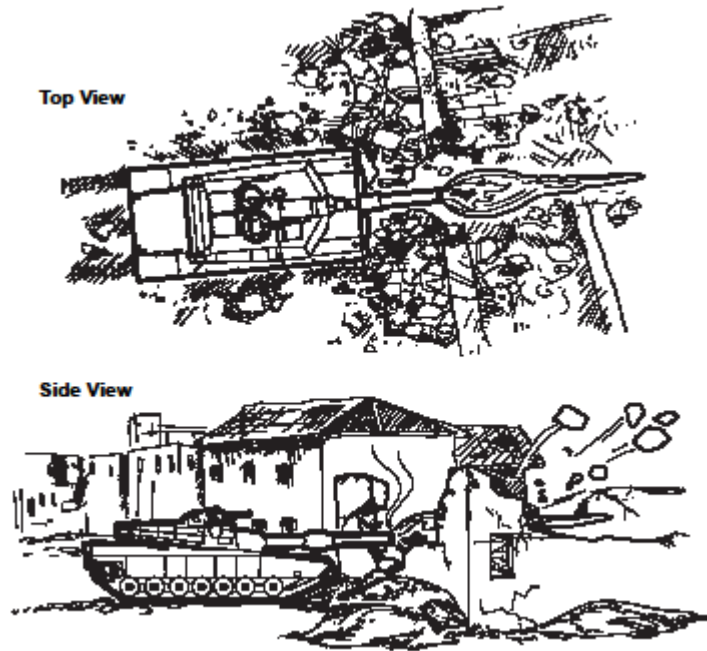

Figure 6-3. Hull Down Position.

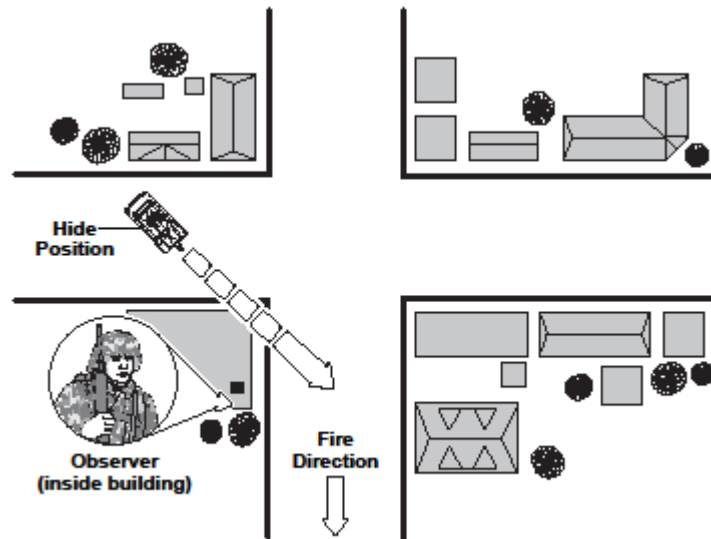

Figure 6-4. Hide Position.

This Page Intentionally Left Blank

CHAPTER 7

SCOUT AND ANTITANK PLATOONS

Scout and antitank platoons in Marine tank battalions provide them with organic reconnaissance, security, and countermechanized capabilities. These capabilities are an integral part of Marine Corps tank battalion operations and are important helpers in shaping the battlefield.

Scout Platoon

The scout platoon is one of the battalion commander's primary sources of organic combat intelligence, both before and during the battle. It is designed to gain and maintain visual contact with the enemy without becoming directly engaged to build a picture of the battlefield.

Mission

The tank battalion's scout platoon performs reconnaissance, provides limited security, and assists in controlling the battalion's movements. The platoon is not organized or equipped to conduct independent offensive, defensive, or retrograde operations. It operates as part of the tank battalion and should be assigned missions that capitalize on its reconnaissance capabilities. The scout platoon is one of the battalion commander's primary sources of organic combat intelligence before and during the battle. Although the platoon has an antitank capability, it cannot perform its scouting roles when employed as an antitank force.

Organization

The scout platoon is organized into two scout sections and one headquarters section. The scout platoon leadership consists of the platoon commander, platoon sergeant, and two scout section leaders. See figure 7-1 for equipment breakdown.

Employment

There are six fundamentals required for the successful employment of the tank battalion scout platoon:

- *Use maximum reconnaissance force forward.* Scouts should not be kept in reserve. Scouts do not need to be on-line and oriented forward; rather, all available scouts must be employed executing reconnaissance tasks.
- *Orient on the reconnaissance objective.* The platoon's scheme of maneuver is focused toward a specific objective or set of objectives based on the operation order and the battalion commander's intent.
- *Report all information rapidly and accurately.* Commanders base their decisions and plans on the battlefield information that scouts provide during reconnaissance. Since information loses value over time, scouts must report all information exactly as it is seen and as fast as possible. They must never assume, distort, or exaggerate information. Inaccurate information is dangerous.

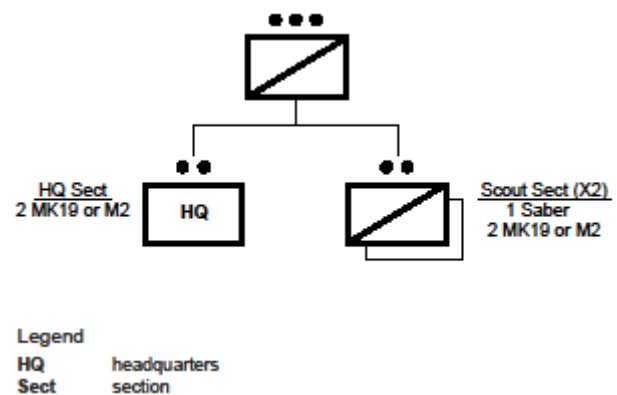

Figure 7-1. Scout Platoon Organization and Equipment Breakdown.

- *Retain freedom to maneuver.* Scouts must be able to maneuver on the battlefield. If they are fixed on a position by the enemy, scouts must free themselves; otherwise, they can no longer accomplish their mission. Scouts must continually maintain an awareness of tactical developments. They must employ the proper tactical movement and react appropriately to unexpected situations. If contact is made, the platoon commander develops the situation at the lowest possible level while retaining the initiative, the ability to continue the mission, and the ability to maneuver his/her other elements.
- *Gain and maintain enemy contact.* Scouts seek visual contact with the enemy on favorable terms. They employ sound tactical movement, target acquisition methods, and appropriate actions in order to see the enemy first, thereby retaining the initiative and control of the situation. Once scouts find the enemy, they use all available means to maintain contact until directed to do otherwise.
- *Develop the situation rapidly.* Whether scouts encounter an obstacle or the enemy, they must quickly assess the situation. If scouts encounter the enemy, they—
 - ◆ Determine the enemy's size, composition, and disposition. Reporting should follow the standard SALUTE [size, activity, location, unit, time, and equipment] report format in order to provide the commander with a clearer view of the enemy situation.
 - ◆ Find the enemy's flanks.
 - ◆ Find any barriers or obstacles surrounding the enemy position and determine if any other enemy forces can support the position.

If the scouts encounter an obstacle, they find and mark a bypass or, if appropriate, execute or assist in a breach. Such actions must be accomplished with minimum guidance from higher headquarters.

Reconnaissance Missions

The three reconnaissance missions that can be assigned to the scout platoon are route reconnaissance, zone reconnaissance, and area

reconnaissance. During defensive operations—while conducting security operations—the scout platoon can be tasked to conduct a screen.

The route reconnaissance effort occurs along a specific line of communications, such as a road, railway, or waterway. It provides new or updated information on route conditions and activities along a specific route (see chap. 2 for tank-specific considerations).

A zone reconnaissance is a directed effort to obtain detailed information within a zone defined by boundaries. Zone reconnaissance provides data concerning all routes, obstacles (to include chemical or radiological contamination), terrain, and enemy forces within the zone of action.

An area reconnaissance provides detailed information concerning the terrain or enemy activity within a prescribed area, such as a town, ridgeline, woods, or other feature critical to operations. Areas are smaller than zones and a zone reconnaissance may include several areas. At its most basic level, an area reconnaissance could be made of a single point, such as a bridge or an installation.

A screen force maintains surveillance for its main body forces. The screening element provides early warning to the main maneuver force about the enemy's size, composition, and disposition. The intelligence provided by the screen force allows the commander of the maneuver force to make accurate decisions regarding deployment and positioning of the main body in the best way to defeat the enemy's main body. A screen force is not to become decisively engaged with the enemy; rather, to impede, destroy, or harass enemy reconnaissance within its capability (see chap. 2 for tank-specific considerations).

Additional Tasks for Scout Platoon

In addition to its primary missions, the scout platoon can—

- Conduct liaison between units.
- Perform quartering party duties.

- Provide traffic control.
- Participate in area security.

Capabilities and Limitations

The scout platoon can—

- Conduct limited pioneer and demolition work.
- Conduct chemical detection and radiological survey and monitoring operations.
- Operate as a FST within the security area with forward observer/FAC augmentation.
- Staff up to six observation posts for short durations or up to three observation posts for long durations.
- Reconnoiter two routes simultaneously (for trafficability only).
- Reconnoiter a zone 3 to 5 kilometers wide, depending on METT-T conditions.
- Carry a basic load of demolitions and has limited obstacle creation ability.
- Breach hasty point obstacles.

The scout platoon is limited in that it—

- Depends on its parent unit for combat support and CSS augmentation.
- Is limited in its ability to destroy or repel enemy reconnaissance units during screening operations.
- Has a limited dismounted capability; it must be properly task-organized to conduct dismounted operations.
- Is restricted to the range of communications and the range of supporting indirect fire when operating away from the main body.

Antitank Platoon

The antitank platoon is the tank battalion's motorized countermechanized capability. It is a flexible element that can be employed to support various missions, from screening to antiarmor ambushes. The versatility of the HMMWV and array of firepower within the platoon make it a viable threat to enemy mechanized forces.

Mission

The primary mission of the antitank platoon is to provide countermechanized support that uses the Saber missile system to engage and destroy enemy armored vehicles, particularly tanks. When not performing its primary mission, the antitank platoon may assume a secondary mission of engaging other point targets or providing limited security to the commander in the form of a screen or observation posts.

Organization

The antitank platoon is organized into three sections and a headquarters section. The antitank platoon leadership consists of the platoon commander, platoon sergeant, and three section leaders. See figure 7-2, on page 7-4, for equipment breakdown.

Employment

The antitank platoon may be employed as an organic unit for a specific mission, such as setting a screen or a blocking position, but it can also be broken down into sections that are then attached in direct or general support to individual tank or infantry companies. The tube-launched, optically-tracked, wire-guided missile's long standoff range allows it to cover likely avenues of approach for armored vehicles, which allows tanks to conduct offensive missions.

Missions that are typically assigned to the antitank platoon are—

- *Attack by fire.* A tactical mission in which a commander uses direct fires, supported by indirect fires, to engage an enemy without closing with to destroy, suppress, fix, or deceive them.
- *Support by fire.* A tactical mission task in which a maneuver force moves to a position where it can engage the enemy by direct fire in support of another maneuvering force.
- *Screen.* A screen force maintains surveillance for its main body forces. The screening element provides early warning to the main maneuver

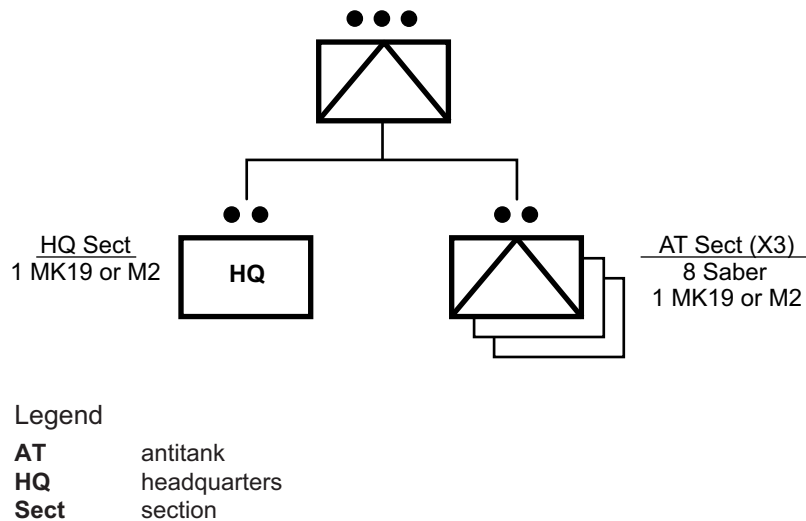

Figure 7-2. Antitank Platoon Organization.

force about the enemy's size, composition, and disposition. The intelligence provided by the screen force allows the commander of the maneuver force to make accurate decisions regarding deployment and positioning of the main body in the best way to defeat the enemy's main body. A screen force is not to become decisively engaged with the enemy; its task is to impede, destroy, or harass enemy reconnaissance within its capability.

- *Rear area security.* Security operations conducted to protect the support functions of the battalion in the rear area.
- *Local security.* Low-level security operations conducted near a unit to prevent surprise by the enemy. Local security elements are established in the proximity of a unit to prevent surprise by the enemy.
- *Convoy security.* A specialized kind of security operations conducted to protect convoys.
- *Follow and assume.* A tactical mission task in which a second committed force follows a force conducting an offensive operation and is prepared to continue the mission if the lead force is fixed, attrited, or unable to continue.
- *Antiarmor ambush.* A surprise attack by fire from concealed positions on a moving or temporarily halted enemy.

Capabilities and Limitations

The antitank platoon can—

- Conduct chemical detection and radiological survey and monitoring operations.
- Operate as FST within the security area with forward observer/FAC augmentation.
- Occupy several observation posts simultaneously.
- Conduct route reconnaissance.
- Create obstacles on a limited basis.
- Perform the reserve mission.
- Secure lines of communications.

The antitank platoon is limited by its—

- Dependence upon its parent unit for combat support and CSS augmentation.
- Dismount capability as it must be properly task-organized to conduct dismounted operations.
- Employment in squads with a minimum of two launchers, so that the crews can provide mutual support.
- Vulnerability to both direct and indirect fire; therefore, cover and concealment are extremely important.
- Reduced range when firing over water obstacles.

APPENDIX A

ARMOR VEHICLE CHARACTERISTICS

M1A1 Tank

The M1A1 combat (main battle) tank uses high speed, maneuverability, and a variety of weapons to attack and destroy enemy tanks, equipment, and forces (see fig. A-1 on pages A-2 and A-3). The M1A1 combat tank consists of the hull and turret assemblies. The turret can rotate a full 360 degrees.

The M1A1 has the following capabilities:

- Armor-protected precision fire:
 - ◆ Stabilized 120-mm smooth bore cannon (M256). Planning considerations include a 2,500-meter offensive trigger line and a 3,000-meter defensive trigger line.
 - ◆ Fire enhancement package, which gives enhanced lethality to FST procedures and enables target acquisition in limited visibility conditions. It consists of—
 - FTL system: 10-digit grid out to 8 kilometers and 10-digit grid to tank's location.
 - North finding module, which sends an azimuth to the target.
 - Eyesafe laser range finder, which has a range to the target out to 8 kilometers.
 - ◆ Weapons and ammunition (see tank characteristics in this appendix).
 - ◆ Stabilized Commander's weapon station:
 - Day/night capable.
 - Fired under armor protection.
 - Capable of engaging targets independently, while stationary or on the move.
- Mobility/countermobility:
 - ◆ Traverse various types of terrain at high speed.
 - ◆ Traverse 60-degree front slope/40-degree side slope.

- ◆ Track width mine plow enables hasty breaching (see app. E).
- ◆ Multipurpose tank blade enables hasty obstacle reduction (see app. E).

The M1A1 has the following limitations:

- Size and weight (see tank characteristics in this appendix).
- Dead space (see figs. 6-1 on page 6-4 and 6-2 on page 6-5).
- Fuel consumption (see app. B).

The M1A1 has the following characteristics:

- 4-armor Marines: commander, gunner, loader, and driver.
 - Armament:
 - ◆ Main gun: M256, 120-mm.
 - ◆ Ammunition: 120-mm combustible cartridge.
 - CBRN overpressure system (see app. D).
 - Machine guns:
 - ◆ Coaxial machine gun: M240C, 7.62-mm:
 - Maximum effective range: 900 meters (tracer burnout).
 - Maximum range: 3,725 meters.
 - ◆ Loader's machine gun: M240C, 7.62-mm:
 - Maximum effective range: 900 meters (tracer burnout).
 - Maximum range: 3,725 meters.
 - ◆ Commander's machine gun: M2 heavy-barrel, .50 caliber:
 - Maximum effective range: 1,800 meters (tracer burnout).
 - Maximum range: 6,700 meters.
 - ◆ M4, 5.56-mm rifle (1 per armor Marine).
 - ◆ M250, grenade launcher.
- Ammunition quantity:
 - ◆ 120-mm (main gun), 40 rounds.
 - ◆ M240C, 7.62-mm coaxial machine gun, 10,000 rounds.

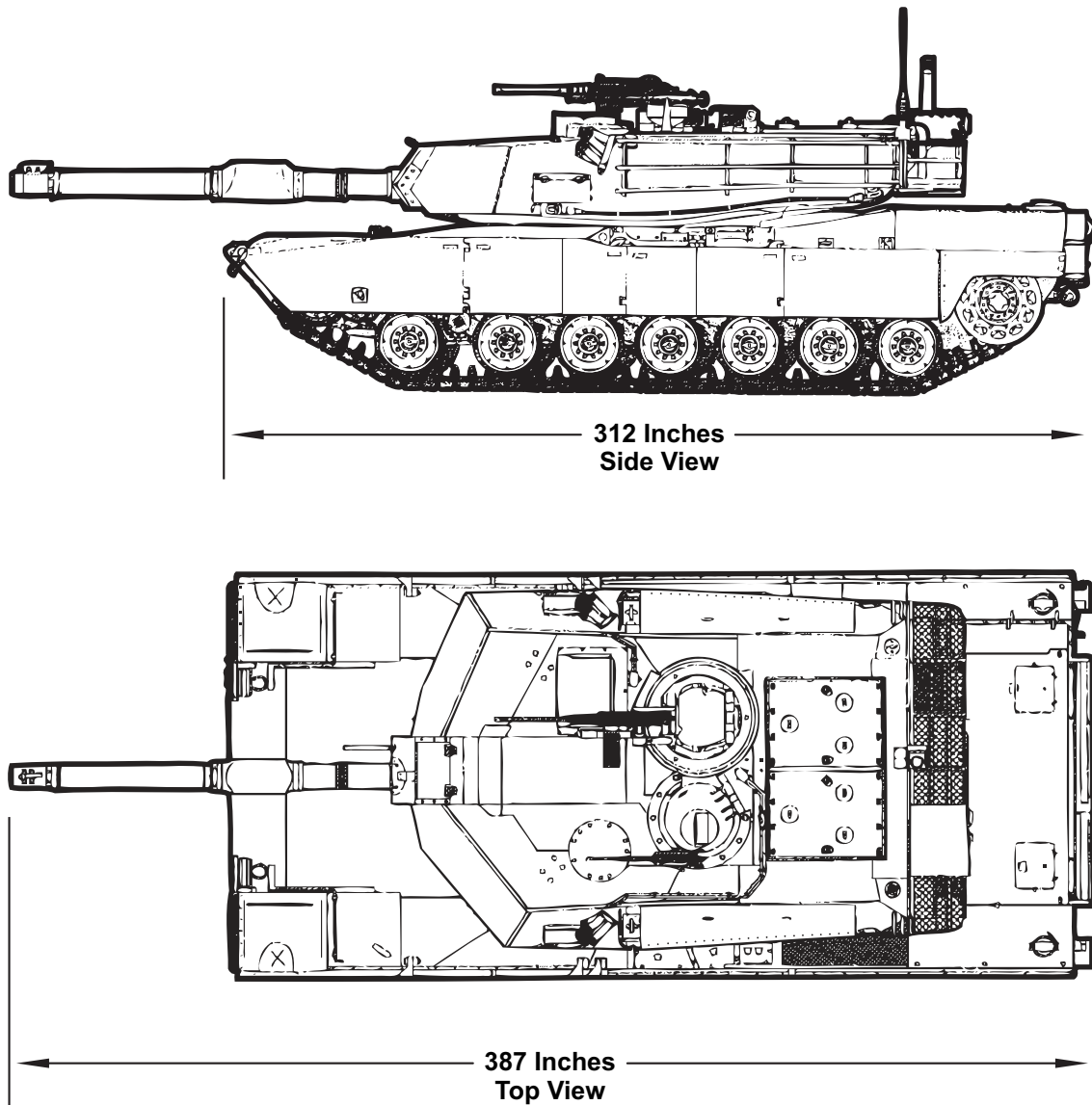

Figure A-1. M1A1 Tank.

- ◆ M240C, 7.62-mm loader's machine gun, 1,400 rounds.
- ◆ .50 caliber commander's machine gun, 1,000 rounds.
- ◆ G826 and GG24 series (smoke grenades for grenade launcher), 24 grenades.
- ◆ M4, 5.56-mm, 720 rounds.
- Turbine engine.
- Transmission:
 - ◆ Model X1100-3B.
 - ◆ Range: 4 speeds forward, 2 reverse, with pivot and neutral selections.
- Performance and specifications:
 - ◆ Forward speed, maximum (on paved level surface): 42 mph.
 - ◆ Reverse speed, maximum (on paved level surface): 25 mph.
 - ◆ Range (dry level secondary roads without refueling): 273 to 298 miles (approximately 8 hours).
 - ◆ Forward climb of a vertical obstacle: 49 inches.
 - ◆ Maximum width of forward crossable ditch: 108 inches.

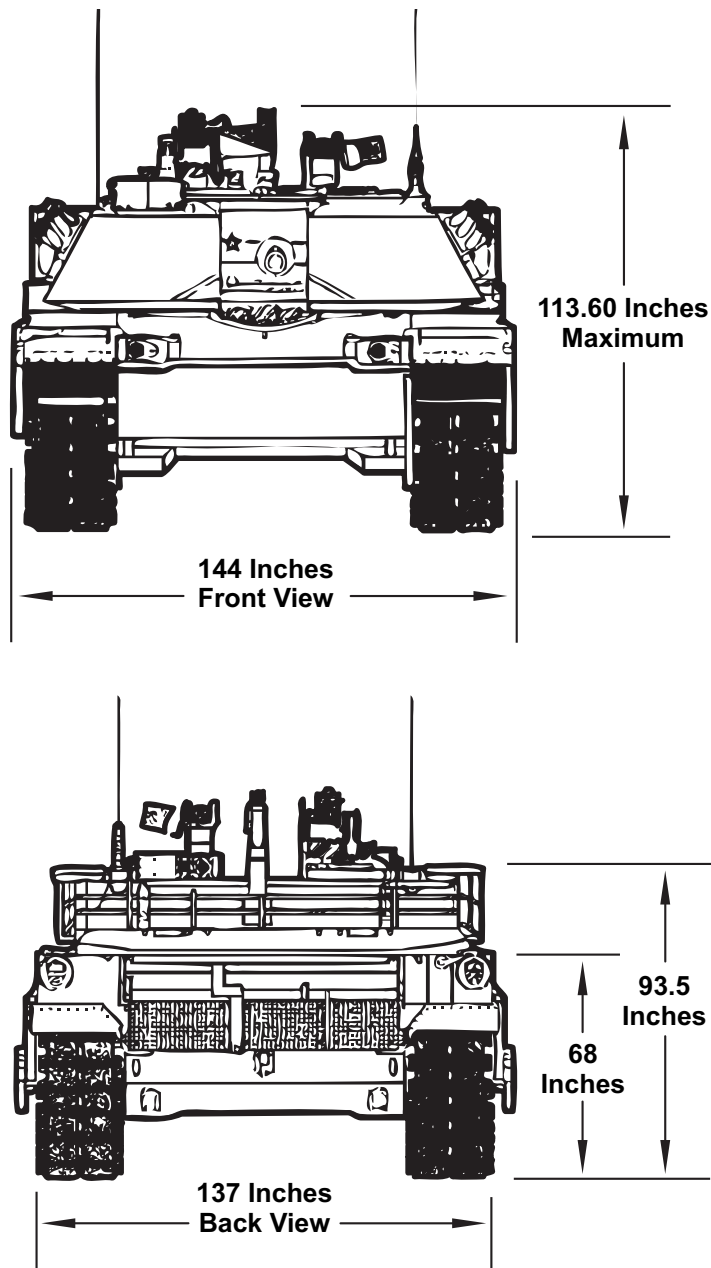

Figure A-1. M1A1 Tank (Continued).

- ◆ Fording depth:
 - Without kit: 48 inches.
 - With kit: 93.5 inches (turret roof).
- Weight:
 - ◆ Combat loaded: 67.6 tons.
 - ◆ Military load classification: 68 tons.

Note: The addition of mission-specific gear, such as a mine plows and tank urban survivability kit will increase the MLC. Tank

unit leadership should be consulted for specific weight considerations.

- Dimensions:
 - ◆ Tank length (not including main gun, with the main gun rearward over the back deck): 356 inches.
 - ◆ Tank length (main gun forward facing center line of tank): 387 inches.
 - ◆ Width: 144 inches.
 - ◆ Height (ground to turret roof): 96 inches.

- ◆ Height (maximum overall): 114 inches.
- ◆ Ground clearance (center portion of the hull): 19 inches.
- ◆ Ground clearance (other portion of hull structure): 16.5 inches.
- ◆ Ground pressure: 15.00 psi.
- Fuels and oils:
 - ◆ Fuel tanks (total in tank): 504.4 gallons.
 - ◆ Transmission, initial fill: 40 to 45 gallons.
 - ◆ Transmission, refill approximate: 30 to 35 gallons.
 - ◆ Engine lubrication oil tank (refill, approximate): 17 quarts.
 - ◆ Recommended fuel types (switching between fuel types increases fuel filter consumption):
 - DF-1.
 - DF-2.
 - JP-8.
 - DF-A.
 - JP-4.
 - JP-5.
 - F-24

For more information on the M1A1 tank, refer to TM 08953A-10, *Tank M1A1 (120-mm Gun)*.

M88A2 Recovery Vehicle

The M88A2 heavy recovery vehicle is an armored, full-tracked, low silhouette vehicle (see fig. A-2). It is used for hoisting, winching, and towing operations for all vehicles up to 70 tons (63.49 metric tons). It is equipped to assist in repairing disabled vehicles under field conditions. Refer to Field Manual 4-30.3, *Maintenance Operations and Procedures*, for recovery methods using the vehicle's equipment.

The M88A2 has the following capabilities:

- Maintenance.
- Lift capacity to support field maintenance.
- Necessary equipment on board to support second echelon maintenance and repairs.

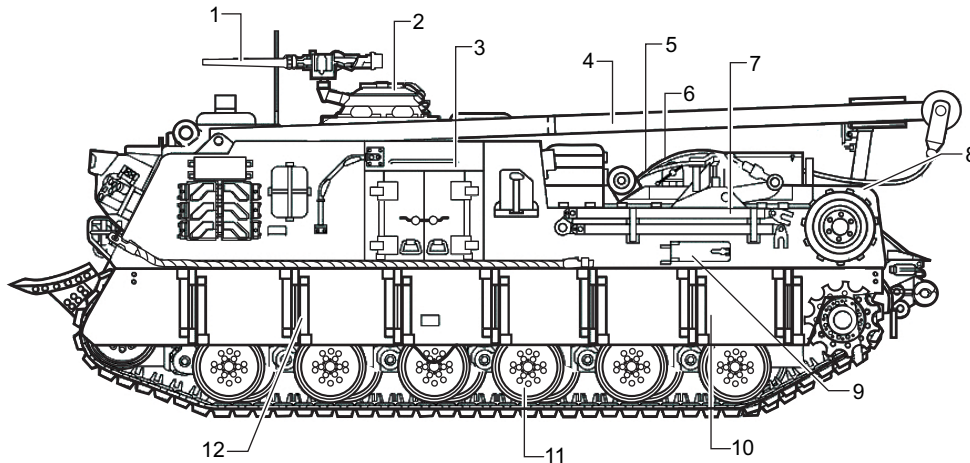

1. M48 caliber .50, machine gun
2. Commander's Weapon Station (CWS)
3. Personnel door, left side
4. Boom
5. Tarpaulin and 100-ft rope
6. Snatch block, 35-ton

7. Tow bar
8. Crow bar (2)
9. Left side stowage compartment door
10. Bumper sprint (4)
11. Roadwheel (12)
12. Shock absorber (6)

Figure A-2. M88A2 Recovery Vehicle.

- Hull and cab armor-protected from 30-mm direct fire.
- Gas-particulate filter unit (CBRN capability).
- M239 smoke grenade system.
- Exhaust smoke generating system.
- Deep water fording kit.
- MK-48 .50 caliber machine gun.
- Three M4, 5.56-mm rifles.

The M88A2 has the following limitations:

- Limited offensive armament.
- Max speed considerably slower than M1A1.
- Size and weight.

The M88A2 has the following characteristics:

- A three-person crew consisting of the commander, operator, and mechanic/rigger.
- Armament:
 - ◆ MK-48 .50 caliber machine gun.
 - ◆ Three M4, 5.56-mm rifles.
 - ◆ Light antiarmor weapon rockets.
- Ammunitions quantity:
 - ◆ M2 heavy-barrel, .50 caliber machine gun, 900 rounds.
 - ◆ M4, 5.56-mm rifle, 540 rounds.
- Engine:
 - ◆ 12-cylinder diesel engine.
 - ◆ 4-cycle, air-cooled model AVDS-1790-8CR.
- Transmission: twin disc, XT-1410-5A.
- Performance and specifications:
 - ◆ Speed, maximum (without towed load): 25 mph.
 - ◆ Cruising range, maximum: 300 miles.
 - ◆ Grade ascending ability, maximum: 60 percent.
 - ◆ Grade descending ability, maximum: 60 percent.

- ◆ Side slope grade, maximum: 30 percent.
- ◆ Maximum vertical wall: 42 inches.
- ◆ Maximum trench crossing width: 102 inches.
- ◆ Minimum turning radius: pivots in one vehicle length.
- ◆ Draw bar pull: 107,000 pounds.
- ◆ Boom lift height:
 - At 8-foot reach: 22.5 feet.
 - At 4-foot reach: 25.0 feet.
- ◆ Hoist winch capacity, (4-part line): 70,000 pounds.
- ◆ Boom capacity:
 - Spade up: 4-part line, with lockout blocks installed: 50,000 pounds.
 - Spade down: 70,000 pounds.
 - Main winch capacity, single line, continuous pull: 140,000 pounds.
- ◆ Auxiliary winch capacity, single line: 6,000 pounds.
- ◆ Fording depth:
 - Without fording kit: 56 inches.
 - With fording kit: 90 inches.
- Weight, combat loaded: 70 MLC.
- Dimensions:
 - ◆ Length: 28.33 feet.
 - ◆ Width: 12 feet.
 - ◆ Height: 9.75 feet.
 - ◆ Ground pressure: 13.7 psi.
- Fuels and oils:
 - ◆ Fuel tanks: 413 gallons.
 - ◆ Main engine crankcase (refill): 18.5 gallons.
 - ◆ Transmission (refill): 17 gallons.
 - ◆ Main winch: 9.5 gallons.
 - ◆ Hoist winch: 9 pints.
 - ◆ Auxiliary winch: 6 pints.
 - ◆ Hydraulic system: 80 gallons.
 - ◆ Electromagnetic clutch: 5.2 quarts.

This Page Intentionally Left Blank

APPENDIX B

LOGISTIC CONSIDERATIONS

The logistic estimates within this appendix are designed to give a general scope of the logistic requirements and capabilities of a tank battalion. Any planning requirements should be referred to the tank unit for development of staff estimates. Tank battalions can also produce detailed logistic smart packs upon request.

Fuel

Tanks require a large amount of fuel. Heavy expanded mobile tactical trucks are required to refuel a tank company quickly and efficiently. The M1A1 tank engine can run on a variety of fuels, such as DF-1, DF-2, DF-A, JP-4, and JP-5, but JP-8 is the preferred fuel. Fuel requirements are as follows:

- One M1A1 tank: 504.4 gallons.
- Tank platoon (4 tanks): 2,017.6 gallons.
- Tank company (14 tanks): 7,061.6 gallons.

Additional Petroleum, Oils, and Lubricants

In addition to fuel, the M1A1 requires other lubricants to keep the tanks functioning properly. Table B-1, on page B-2, shows the type of lubricants and

amounts needed in each M1A1 tank. This table should be used as a guide for logistic planning.

Ammunition Resupply

Tanks carry a large amount of ammunition and can carry several different types of main gun rounds, depending on the mission. See appendix F for a discussion of the types of rounds and their specifications.

Table B-2, on page B-2, can help logisticians plan to properly rearm tank units. Not only must the main gun rounds be resupplied, but also the onboard machine guns, the small arms of the tank crews, and the tank smoke grenade launcher rounds must be replenished. The frequency of resupply depends on the type of mission being conducted and the types of targets engaged by the tank units.

Planning Factors

Tables B-3 to B-8, on pages B-2 and B-3, show general logistic planning factors with regard to personnel and equipment within the tank battalion and a tank company.

Table B-1. Petroleum, Oils, and Lubricants Capacity for a Single M1A1 Tank.

POL Placement	Type of POL	Amount per Tank
Engine	Turbo shaft	25 quarts
Transmission	15/40 weight	45 gallons
Final drives	15/40 weight	5.5 quarts
Suspension/shocks	Turbo shaft	30.6 quarts
Suspension/hubs	15/40 weight	20 quarts
Hydraulic system	FRH	20 gallons
Recoil mechanism	FRH	10.3 gallons

Legend
 POL petroleum, oils, and lubricants
 FRH fire resistant hydraulic fluid

Table B-2. Arming Capacity for M1A1 Tank Units.

Ammunition Type	Ammunition Quantity		
	One Tank	Tank Platoon (4 tanks)	Tank Company (14 tanks)
Main gun, 120-mm	40	160	560
M2, .50 caliber	1,000	4,000	14,000
Coaxial, 7.62-mm	10,000	40,000	140,000
Loaders, 7.62-mm	1,400	5,600	19,600
M4, 5.56-mm	720	2,880	10,080
Phosphorous smoke	24	96	336
Thermite grenade	2	8	28
Pistol, 9-mm	400	1,600	5,600

Table B-3. Tank Battalion Personnel Strength.

Marine Officer	Marine Enlisted	Navy Officer	Navy Enlisted
47	725	3	29

Tank battalion personnel table of organization = 804

Table B-4. Tank Company Personnel Strength.

Marine Officer	Marine Enlisted	Navy Officer	Navy Enlisted
5	81	0	0

Tank company personnel table of organization = 86

Table B-5. Tank Battalion Major End Items.

Number	Item
58	M1A1
6	M88A2
37	MTVR
2	MTVR wrecker
8	LVS tandem
1	LVS with M870
2	LVS wrecker
15	Armor HMMWV
26	TOW HMMWV
37	HMMWV utility
3	MRC-148
11	MRC-145
1	Tram
1	EBFL

Legend
 TOW tube launched, optically tracked, wire guided
 LVS logistic vehicle support
 EBFL extended boom fork lift

Table B-6. Tank Company Major End Items.

Number	Item
14	M1A1
2	M88A2
2	Armor HMMWV
1	MRC-145
6	HMMWV utility

Table B-7. Common Attachments to a Tank Company.

Number	Item
2	MTRV with M105
1	LVS tandem

Legend
 LVS logistic vehicle support

Table B-8. Tank Battalion Logistic Lift Capacity.

Class I		
Quantity	Nomenclature	Total capacity
12	Water pod (900 gallons)	10,800 gallons
9	Water bull (400 gallons)	3,600 gallons
Class III		
Quantity	Nomenclature	Total capacity
28	Fuel pod (900 gallons)	25,200 gallons
Class V		
Combat Trains	Field Trains	Company Trains
2 MTRVs with M105	7 MTRV with M105	1 MTRV with M105
1 LVS tandem	1 LVS tandem	
Vehicle Lift Capacity		
LVS tandem	540 main gun rounds (18 pallets)	
MTRV	180 main gun rounds (6 pallets)	

Legend
 LVS logistic vehicle support

This Page Intentionally Left Blank

APPENDIX C

OPERATIONS IN EXTREME ENVIRONMENTS

Tank employment in changing operational conditions and environments presents special problems, challenges, and situations. Planners must consider the tank's capabilities and limitations, the principles of tank employment, and the environmental conditions. Each operation may require modifying tactics and augmenting equipment to support the environmental conditions. (For detailed discussions on operating tanks in varying environmental conditions, refer to the M1A1's technical manuals.)

Jungle Operations

Jungle operations are addressed in depth in MCWP 3-35.5, *Jungle Operations*. Jungle combat involves operations with such impediments as swamps, undulating terrain, extreme heat, heavy rains, and areas largely overgrown with thick tropical foliage. Marine tank crews must acclimate to live and fight in the jungle because tank maintenance and operations are exhausting in that environment. The basics of successful jungle operations are decentralized control, flexibility, security, and intelligence.

Cover and concealment are excellent in jungle terrain and increase the possibility of achieving surprise. As a result, both the attacker and the defender usually commit large portions of available forces to security missions; however, the restrictive nature of a jungle environment impedes typical tank operations.

Restrictions on observation and fields of fire may reduce the capabilities of tanks to acquire targets and deliver accurate direct fires. Additionally, the difficulties associated with jungle operations increase in proportion to the size of the force involved. These limitations drive the conduct of

operations to the company, platoon, and individual tank crew level.

Despite their limitations, tank employment can still be effective in jungle operations. Although tanks must move slower in the jungle due to difficult trafficability, they are one of the few vehicles capable of traversing through thick foliage and undergrowth—on which wheeled vehicles could never operate. In addition, tanks can provide effective reconnaissance by fire and suppressive fires for supported infantry. The tank's ability to produce a large volume of fire from its machine guns and main gun antipersonnel rounds can be devastating to the enemy as long as the tank is protected by an infantry security element.

Tank considerations during a jungle operation include the following:

- The dense foliage and weather alter the effective range of a weapon system. Engagements for tanks are usually at close range and require quick target recognition by the tank crews.
- Units must allow for slower movement and restricted fire support. The jungle's limited visibility may make the observation and adjustment of indirect fires difficult.
- Heat, thick vegetation and rugged terrain will tire Marines rapidly; supported infantry can ride on the back of the tanks if enemy contact is not expected.

Desert Operations

Highly mobile forces play a dominant role in operations in desert regions. Tanks provide the freedom to maneuver in the vastness of these regions that favor a fluid type of warfare that is characterized by dispersed formations on

extended frontages with considerable depth. Properly employed and maintained, the tank can be the most decisive supporting arm available to the MAGTF commander during desert operations.

Desert topography may consist of loose sand and sand dunes that greatly impede the movement of vehicles or it may have a hard surface that facilitates large mechanized formations. Units must modify and adapt their equipment and tactics to a dusty and rugged landscape. (See MCWP 3-35.6, *Desert Operations*, for detailed information.)

Desert offensive operations tend to favor wide envelopments and fast and wide flanking movements by armored formations because of the freedom to maneuver. Because of the limited concealment offered by the bare terrain, units must surprise the enemy by using deception, appropriate security measures, and rapid movement; moreover, commanders must exploit periods of limited visibility.

Defensive operations in desert regions emphasize mobility and flexibility. Commanders should make provisions for long-range direct fire weapons, construction of extensive obstacle systems to canalize or slow the enemy, a high degree of mobility, and secure communications. The organization of the defense should emphasize measures against both air and armored attack. Long-range direct fire capability makes the tank an ideal weapon in desert terrain. The long-range fields of fire common to desert areas tend to allow all weapon systems to engage at their maximum range; however, these same extended engagement ranges hinder positive target identification.

Mountain Operations

Rugged, compartmented terrain with steep slopes and few natural or manmade lines of communications generally characterize militarily significant mountains. The compartmented terrain causes a corresponding compartmentalization of military operations. Successful mountain operations

require special equipment, training, acclimation of personnel to altitude conditions, self-discipline, and modifications of standard tactics and procedures. (Fleet Marine Force Manual 7-29, *Mountain Operations* [currently under revision as MCWP 3-35.1, *Mountain Warfare Operations*], provides additional information.)

The focal point of mountain operations is to obtain/maintain control of heights. Key terrain features normally include those heights that dominate lines of communications, such as mountain passes, roads, bridges, and railroads. Fighting from higher ground offers distinct tactical advantages. Tanks are best used in this environment to control key terrain, defensive positions, and strongpoints. Restricted mechanized routes in the mountains do not lend themselves to maneuver warfare of mechanized units. Tightly canalized routes should be anticipated by mechanized units and recognized as danger areas that require good infantry security until the units are clear of the area. Inherent in mountain operations are the difficulties that the terrain offers to movement, so operations in mountainous regions take longer than normal to plan and execute. Key mountain operational characteristics include the following:

- Communications and sustainment are difficult to execute in rugged terrain. In general, operations in mountainous terrain slow and restrict maneuver and make communications and resupply of tanks difficult.
- Defenses may have to locate on the military crest to fire into an engagement area. Mountainous terrain can be either a dangerous obstacle to operations or a valuable aid, according to how well it is understood and to what extent the tank commander takes advantage of its particular characteristics.
- Night and periods of limited visibility are the best movement times due to the extended range of observation from enemy positions. Movement times are slower due to terrain and altitude effects. Any differences in elevation over the march route also have an impact on unit movement times.

- The terrain reduces the effectiveness of firepower. The M1A1 tank has only a limited ability to depress its main gun. The ability to elevate its main gun should also be considered when employing the tanks.
- Centralized planning and decentralized small unit execution characterize operations because the terrain limits the commander's capability to directly control operations. Command and control of tanks is therefore decentralized with small units often operating independently. Tanks are highly effective when task-organized down to the section level and when provided infantry support.
- The role of the tank in a mountainous environment is much the same as in the MOUT environment. Tanks provide armor-protected firepower to reduce obstacles and field fortifications in support of the infantry commander's scheme of maneuver.

Operations in Deep Snow and Extreme Cold

Deep snow and extreme cold weather present employment problems in operations involving tanks, which increase engineer support requirements and may require the extensive use of lines of communication. Planning and training can reduce the effect of the climatic conditions, but commanders and their staffs must understand the impact that these severe conditions impose on tank operations. Many of the missions assigned to tanks are the same as those assigned in normal operations and the tactics and techniques employed in offensive and defensive operations are also similar. (See MCWP 3-35.1 for detailed information on cold weather operations.)

Tactical employment is modified to offset the characteristics of the area and its weather. When planning tactical operations for execution during rigorous winter weather, commanders must carefully consider the probable effects of weather upon operations, the health of Marines, supply, evacuation, and the maintenance of lines of communication. Ice, deep snow, and extreme cold weather modify the normal use of terrain features. Planning considerations during operations in snow or extreme cold weather include the following:

- Operations take longer than normal to plan and execute.
- Tanks are mostly metal, which can become difficult to work around in extreme cold. Gloves have to be worn at all times by the crews, slowing the ability to operate/maintain the tank.
- Cold weather impacts a weapon's reliability; therefore, the M1A1's machine guns require the same cold weather considerations as dismounted machine guns.
- Tanks can generally negotiate deep snow better than wheeled vehicles if there has been enough time to properly prepare the tank track for cold weather operations. Packed snow and ice can cause tracked vehicles to slide and possibly lose control, particularly on hills or roads with steep inclines. Infantry on roads should stay clear of heavy tracked vehicles in these conditions while they are moving.
- Concealment and camouflage are more difficult due to white snow. Depending upon the mission and environment, tanks may need to be painted white for better camouflaging.
- Requirements for CSS increase.

This Page Intentionally Left Blank

APPENDIX D

CHEMICAL, BIOLOGICAL, RADIOLOGICAL, AND NUCLEAR OPERATIONS

Planning

Planning is critical to the success of any operation; therefore, all staff sections must make CBRN considerations an integral part of their operational planning process. A major factor that must be considered is the CBRN effect on individuals and operations once the unit enters an elevated mission-oriented protective posture: the operational tempo will slow, Marines will require more rest and hydration to recover from physical exertion, and the possibility of heat casualties will increase. Proper planning must address threat analysis, vulnerability analysis, mission-oriented protective posture analysis, and the decontamination site.

Nuclear and Radiological Attack

Once a tank unit has reacted to a nuclear or radiological attack, it is capable of performing numerous missions for the supported commander due to the tanks' low transmission factor. Tanks are one of the preferred platforms for radiological operations due to their inherent protection. Their missions include—

- Ground reconnaissance of contaminated area.
- Retrograde guard/screen force for the protected element.
- Continued offensive operations.

Chemical/Biological Attack

Tanks have a CBRN overpressurization system that allows the tank to operate in a highly contaminated environment with less impact on crew capabilities. The tank incorporates limited environmental control and maintains a clean crew environment on a contaminated battlefield. This ability allows the supported commander to continue operations with tank forces while conducting decontamination of more susceptible forces.

Decontamination

Tank decontamination requires special consideration of the amount of water and cleaning agents needed to cover the surface area of the tank and the availability of a water source to accomplish the mission. If the tank has been operating, the engine compartment and the track may not have to be decontaminated due to heat generated during operations.

The detailed procedures and techniques for decontamination operations are discussed in MCWP 3-37.3, *Multiservice Tactics, Techniques, and Procedures for Chemical, Biological, Radiological, and Nuclear Decontamination*.

This Page Intentionally Left Blank

APPENDIX E

BREACHING OPERATIONS

Obstacle breaching is conducted during offensive operations to project combat power to the far side of an obstacle. The commander must understand the various types of obstacles and the capabilities and limitations of available mobility assets.

Fundamentals

During breaching operations, tank units can execute the roles of the support force, breach force, or the assault force. They can provide forces for multiple roles within a breaching operation.

Support Force

Capabilities inherent to a tank unit that executes the role of the support force are—

- Long-range, armor-protected, precision fire.
- Long-range thermal acquisition out to 10 kilometers.
- Control of MAGTF fires under armor protection through the characteristics of the tank (see app. A).
- High speed mobility to establish support by fire positions.

Breach Force

Capabilities inherent to a tank unit that executes the role of the breach force are—

- Armor-protected breach site security.
- Track width mine plow, which has the following capabilities:
 - ◆ Redundant capability to the assault breacher vehicle (ABV).
 - ◆ Mechanical breach.

- Multipurpose tank blade, which has the following capabilities:
 - ◆ Clearance of surface laid obstacles.
 - ◆ Breach of structures.
 - ◆ Limited redundant capability to the medium crawler tractor.
- Breaching tanks become far side security.
- Capable of operating in close proximity to the mine clearing line charge (MICLIC).

A tank platoon may conduct a mechanical breach or serve as the breach force for a larger unit. For example, if the platoon is allocated one plow, the platoon sergeant's wingman normally serves as the breach tank. The platoon sergeant follows immediately behind to proof the lane and provide overwatch. The platoon commander's section follows the platoon sergeant.

If the platoon has two or more plows, it can create multiple lanes, usually 75 to 100 meters apart. The wingman tanks are normally equipped with the plows and the section leaders' tanks follow to proof the lanes and provide overwatch (see fig. E-1 on page E-2).

To create a wider lane, two plow tanks can stagger their movement along a single lane (see fig. E-2 on page E-2). This technique is also used in order to clear a lane through which HMMWVs and other wheeled vehicles can pass without a center lane of mine-ridden spoil. Using figure E-2 as a literal example, a wide lane with no center lane would be created on the right side of the double proofed lane.

Note: The lanes created on the left side would not be double proofed and spoil from the second tank through would be put into the first tank's right lane.

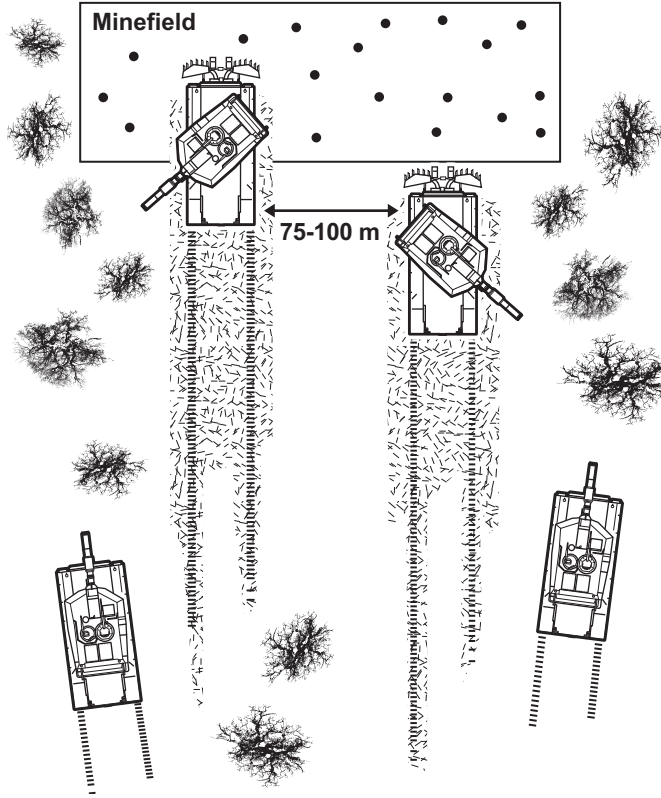

Figure E-1. Plow Tanks Create Multiple Lanes While Section Leaders' Tanks Provide Overwatch.

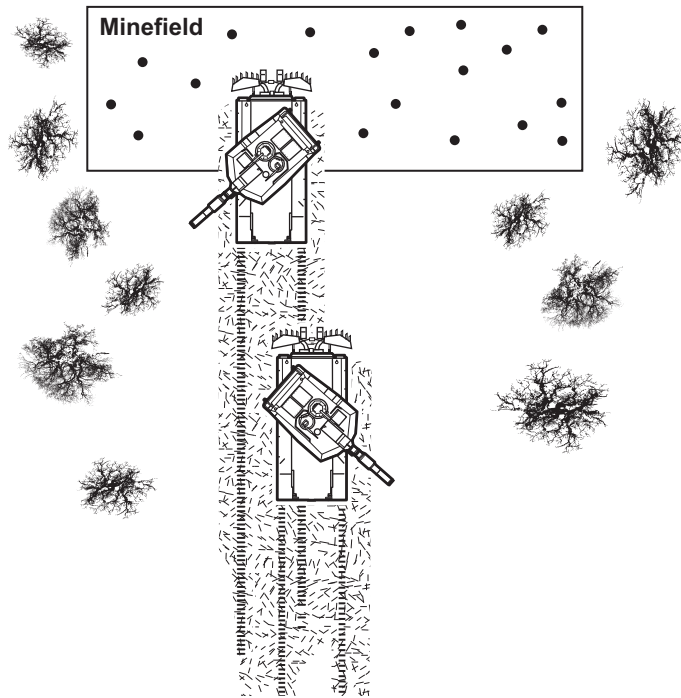

Figure E-2. Plow Tanks Use Staggered Movement to Create a Wider Lane.

After a lane is created and proofed, it is normally turned over to attached engineers for marking. The platoon commander reports the location of the lane and the method of marking to higher headquarters in order to expedite the movement of the assault force. If no engineers are available, an attempt should be made to at least mark the entrance and exit of the breach using North Atlantic Treaty Organization marking procedures. Unit SOPs will dictate marking methods and materials, which commonly include engineer stakes with tape, guides, and chemical lights.

Throughout the operation, the platoon commander provides continuous updates of the breach force's progress to higher headquarters and other elements involved in the breach. The platoon commander also coordinates with the support force for suppressive fires.

Assault Force

The assault force will often move behind the breach force and closely follow the breach vehicles through the new lane (see chap. 2). Capabilities inherent to a tank unit executing the role of the assault force are—

- Long-range, armor-protected, precision fire.
- Control of MAGTF fires under armor protection through the characteristics of the tank (see app. A).

- High speed mobility to establish support by fire positions.

Organic Mobility Assets

The tank battalion has specialized organic mobility assets that enable it to maintain momentum despite enemy countermobility efforts. These assets are designed for, but are not limited to, streamlining the hasty plowing of enemy mine fields, reduction/building of berms, and bridging tank ditches.

Mine Plow

The track width mine plow is used to breach and proof minefields and affords good survivability (see fig. E-3). When fully operational, a tank equipped with a mine plow can quickly clear two, 58-inch wide lanes, one in front of each track.

Note: The plow's dogbone assembly will detonate the tilt rods of mines in the area between the two plowed lanes; however, only plows equipped with the improved dogbone assembly will defeat magnetically activated mines.

The plow must be dropped at least 100 meters before the tank reaches the minefield and it is not lifted until the tank is at least 100 meters past the

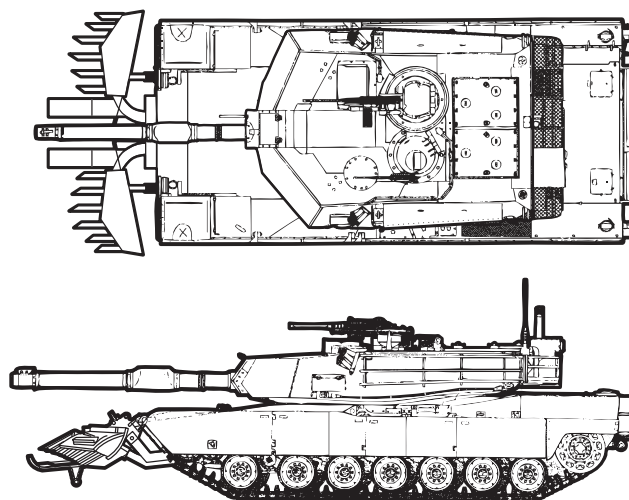

Figure E-3. Track Width Mine Plow for M1A1.

far edge of the minefield. In order to be effective, the plow must have 18 inches of spoil, which limits the tank's speed to 10 mph or less in the lane. The mine plow should be used only in a straight line; it does not work well on hard, rocky, or uneven ground where it cannot maintain adequate spoil. Mine detonation can cause violent upward movement of the blade; therefore, the crew traverses the tank's main gun to the side during plowing to prevent damage to the gun tube. The crew must also ensure the plow's lifting straps don't become entangled in wire obstacles.

Multipurpose Tank Blade

The multipurpose tank blade is designed to conduct obstacle reduction and structure breaching within urban environments (see fig. E-4). It also

has the capability to build hull down fighting positions for tanks, but tank units will require additional engineer support to build a multitiered fighting position for a deliberate defense.

Nonorganic Mobility Assets

There are assets within the MAGTF that, when employed with a tank unit, can enhance capabilities and combat effectiveness during mobility operations. These assets are nonorganic to the tank battalion and should be identified during the planning phase of an operation. Proper rehearsals should be conducted with these assets to ensure that all elements are aware of their employment capabilities and limitations.

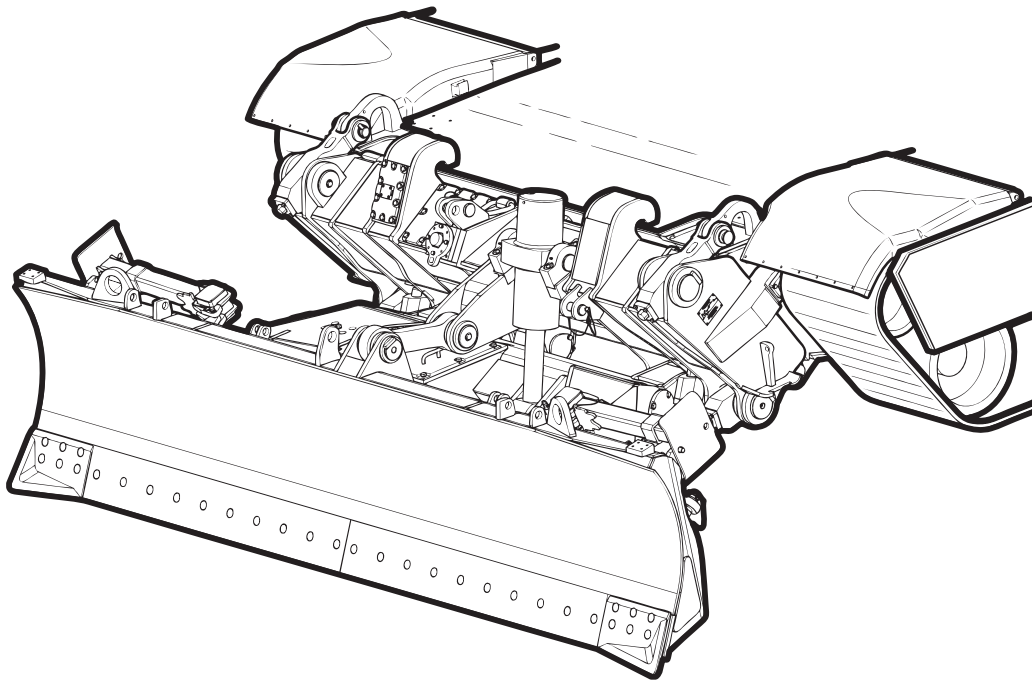

Weight	3.3 tons
Cutting width	145 inches
Cutting depth	12 inches
Install time	20 minutes
Removal time	20 minutes
Construction time (hull down)	12 minutes

Figure E-4. Multipurpose Tank Blade.

Mine Roller

The mine roller is used to identify the forward edges of a minefield and to proof lanes. The roller sweeps a 44-inch path in front of each track and is equipped with a dogbone assembly. It is also effective at breaching wire obstacles; however, is not effective on broken or uneven ground. The mine roller, like the mine plow, will not defeat magnetically fuzed mines unless equipped with the improved dogbone assembly. The main gun must be traversed to the side or rear when contact with a mine is possible or imminent; detonation can throw the roller (or pieces of it) violently upward, possibly damaging the 120-mm main gun. The mine roller can usually withstand two mine explosions before needing repairs or replacement.

Assault Breacher Vehicle

The ABV is a single platform that provides deliberate and in-stride breaching capabilities to the assault force of the MAGTF. The ABV utilizes the M1 chassis, allowing the vehicle to maneuver at the same speed as the tanks and provides similar armor protection. Each vehicle carries two linear demolition charge systems and/or MICLIC, used for clearing lanes through explosive obstacles. It can proof the lane with a full width mine plow and mark the lane at the same time with the lane marking system. In addition, the ABV has a combat dozer blade used for clearing nonexplosive obstacles as well as earth-moving operations. Two other attachments—the rapid ordnance removal system and the surface mine plow—are used to clear surface laid mines, unexploded ordnance, and other surface munitions. During breaching operations, ABVs can be cross-attached to support mechanized forces. The ABV must rely upon the protection and long-range direct fire overwatch provided by the breach force's security element.

Mine Clearing Line Charge

The MICLIC is a MAGTF breaching asset that is organic to the AAV and combat engineer

battalions of the Marine division. There are three types: AAV mine countermeasure (triple shot), ABV (double shot), and trailer mounted (single shot). The MICLIC is used to breach wire and explosive obstacle belts, and the MICLIC clears a lane 100 meters long and 14 meters wide.

Note: The MICLIC must be fired 62 meters from the near side edge of the obstacle belt to get the full 100 meters.

The charge may create two skip zones where the mines are not detonated on the right and left side of the centerline of the cleared lane. The skip zones, which are about 1.5 meters wide, require all MICLIC lanes to be proofed. The MICLIC is effective against pressure-activated antitank mines and against mechanically activated antipersonnel mines. Effectiveness is limited against magnetically activated mines, including scatterable mines and those with multi-impulse (double-impact) or time-delay fuzes. The MICLIC is not effective on severely broken ground where the line charge cannot lay flat. When detonated, the MICLIC has a 1,600-meter danger area radius.

Armored Vehicle-Launched Bridge

The AVLB is primarily employed to cross short gaps (such as narrow streams), antitank ditches, craters, canals, or partially blown bridges. Its span is 18 meters (60 feet) using prepared abutments and 17 meters with unprepared abutments. The capacity of the bridge is one MLC 70 vehicle (waived for M1 series tanks during combat operations). The AVLB launcher, which requires 10 meters of overhead clearance for transportation and operation, is most visible and vulnerable during launching of the bridge. An experienced crew can launch the bridge in 2 to 5 minutes. The AVLB resides within the combat engineer battalion.

Engineer Attachment

The engineer attachment is the most versatile of all breaching assets. It can be used to conduct explosive or manual breaches and proofs and to mark lanes through an obstacle; however, while it

is conducting these breaching and proofing operations, the attachment is extremely vulnerable to enemy direct and indirect fires.

If other breaching assets are unavailable, an infantry or tank platoon can conduct explosive breaches with hand-emplaced charges and/or use

manual breaching kits, which normally consist of grappling hooks, gloves, and wire cutters. At the same time, however, employment of either type of platoon organization in breaching operations has distinct disadvantages: the pace of the breach will be slow and the operation will leave the platoon vulnerable to enemy attack.

APPENDIX F

AMMUNITION

The Abrams tank main armament is the M256, 120-mm smoothbore cannon. It is used to destroy armored vehicles, lightly armored vehicles, helicopters, and defensive positions and to suppress enemy positions and troops in the open. The 120-mm rounds are also used to conduct wall breaching and obstacle reduction. The Abrams fires kinetic energy, chemical energy, special purpose, and training rounds. This appendix discusses the characteristics of both service (combat) and training main gun rounds. Conventional main gun ammunition is classified according to type and use:

- *Armor-defeating ammunition.* Kinetic energy ammunition, such as M829A3, is the primary round used against tank and tank-like targets. In a secondary role, it is used against helicopters and lightly armored vehicles.
- *Multipurpose ammunition.* Chemical energy ammunition—such as M830A1 multipurpose antitank (MPAT), M830 high explosive antitank (HEAT), or multipurpose high explosive—is the primary round used against lightly armored targets and field fortifications. In a secondary role, it can be used against personnel and tank-like targets. When in air mode, M830A1 is the primary round used against helicopters.
- *Antipersonnel.* The M1028 canister round is primarily used against massed troop formations. In a secondary role, it may be used against technical vehicles, such as light trucks, and to breach nonreinforced walls and concertina wire.
- *Training.* Target practice ammunition is used for gunnery training. These rounds provide characteristics similar to service ammunition, without the chemical energy, projectile, or service penetrator.
- *Smoke grenades.* Smoke grenades provide the tank with expedient obsuration for both the vehicle and personnel.

Service Ammunitions

Armor-defeating projectiles use either kinetic energy or chemical energy to penetrate and destroy armored targets.

Armor-defeating Ammunition: M829 A1/A2/A3 Armor-Piercing Fin-Stabilized Discarding Sabot-Tracer

Sabot rounds are the primary armor-defeating round for the 120-mm main gun and are the most accurate of all tank ammunition. Sabot rounds use kinetic energy—the weight and speed of the penetrator—to defeat the target.

The three types of 120-mm sabot rounds currently available for the M1A1 tank are the M829A3 armor-piercing, fin-stabilized, discarding sabot-tracer (APFSDS-T); the M829A2 APFSDS-T; and the M829A1 APFSDS-T (see fig. F-1 on page F-2).

Multipurpose Ammunition

The main gun ammunition—M830 HEAT-tracer, M830A1 MPAT-tracer, and multipurpose high explosive—is designed for the wider array of targets that might be encountered on the battlefield.

M830 High Explosive Antitank-Multipurpose-Tracer

The HEAT multipurpose-tracer round is used primarily against lightly armored targets and field fortifications (see fig. F-2 on page F-2). In its secondary role, it is used against personnel and armored vehicles.

This round depends on chemical energy and not striking velocity; therefore, its ability to penetrate armor is as effective at 4,000 meters as it is at 200 meters (see fig. F-3 on page F-3).

M830A1 Multipurpose Antitank-Tracer

The 120-mm M830A1 MPAT round (see fig. F-4) is a fin-stabilized round that contains a high explosive warhead equipped with a selectable

proximity switch and fuze that allow it to be fired in either air or ground mode. Its primary targets are light-armored ground targets, which are engaged with the fuze set to ground mode, allowing the round to function when it strikes a

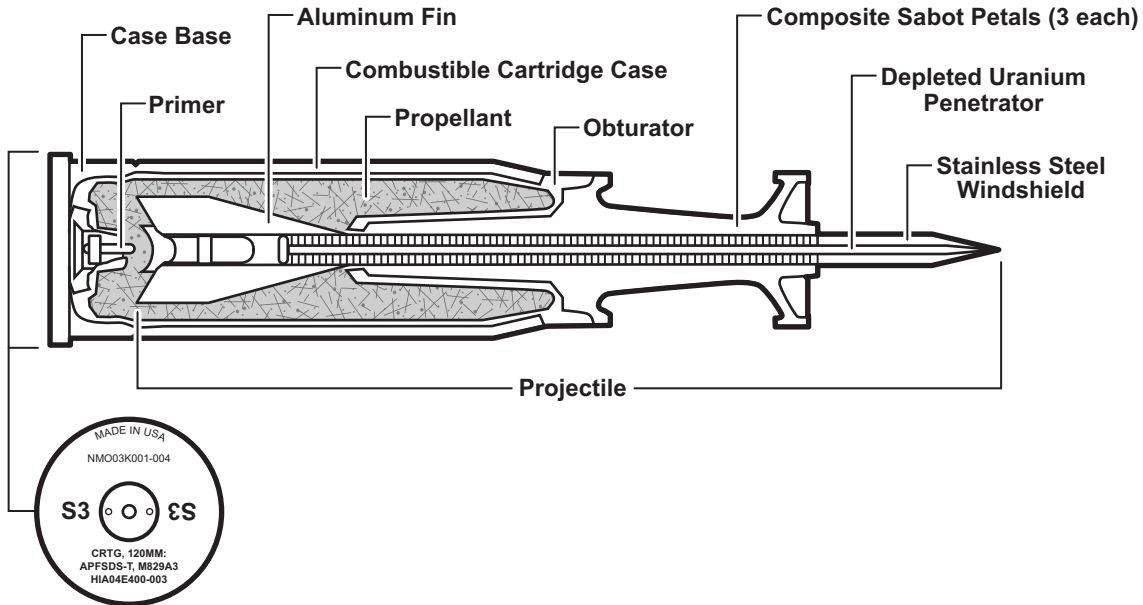
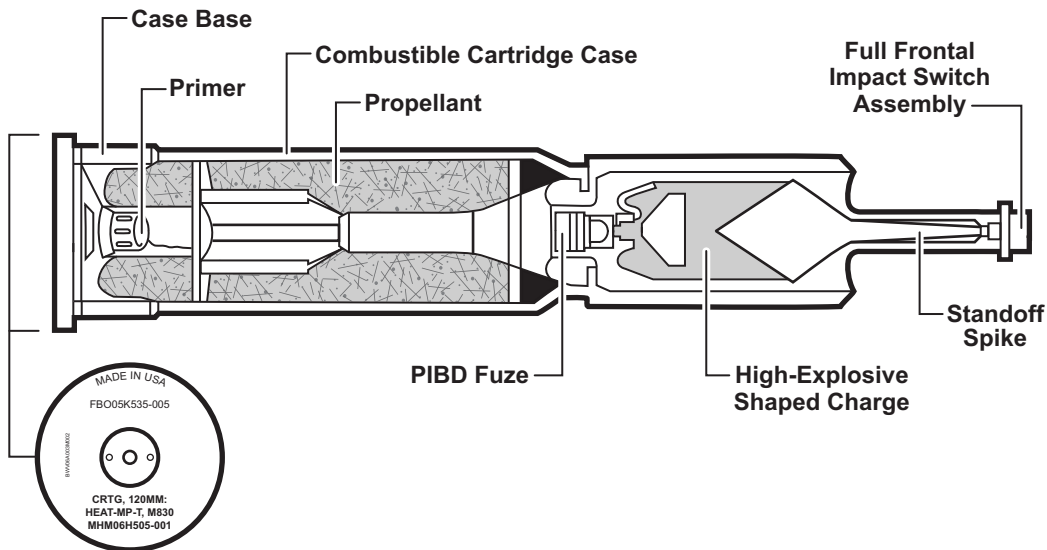

Figure F-1. M829A1/M829A2/M829A3



Legend

PIBD point-initiated base-detonated

Figure F-2. M830 High Explosive Antitank Multipurpose-Tracer (120-mm).

target with either a direct or glancing blow. It may also be used against bunkers, buildings, the flank and rear of enemy tanks, and enemy personnel.

With the switch set to air mode, this round can be used in a self-defense role against enemy helicopters. The round will function either when it

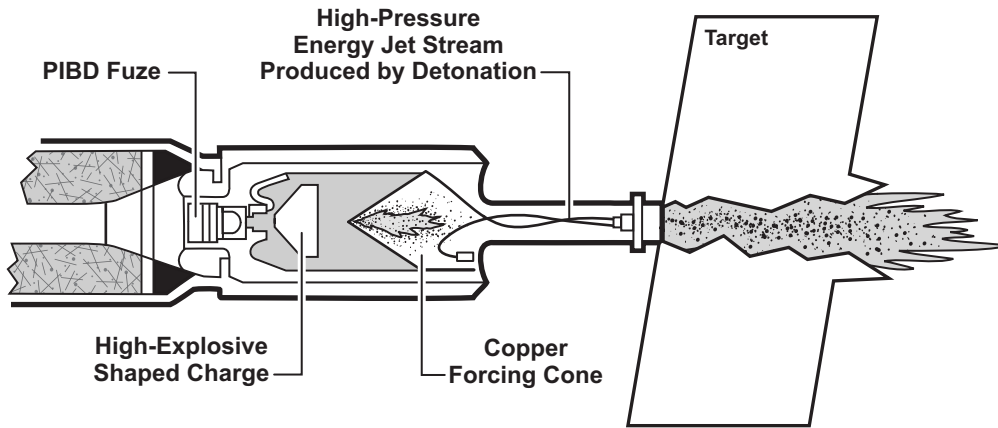

Legend
 PIBD point-initiated base-detonated

Figure F-3. Chemical Energy Ammunition Effects.

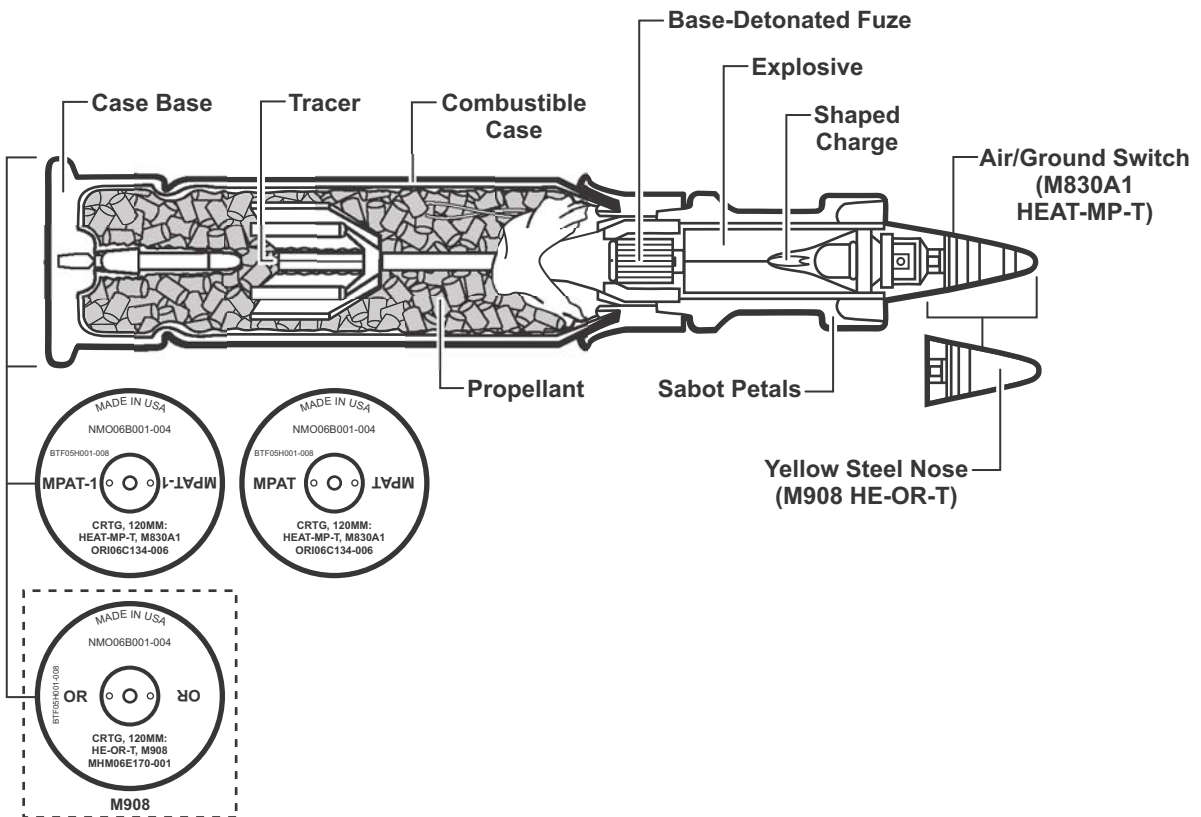

Figure F-4. M830A1 Multipurpose Antitank-Tracer

strikes a target or approaches the vicinity of a target that is detected by the sensor; however, since the sensor is not active until 400 meters, it will not function in air mode at shorter ranges.

Multipurpose High Explosive

The 120-mm multipurpose high explosive cartridge (fig. F-5) is a high explosive round that consists of projectile, programmable fuze, and propulsion section (cartridge case and propellant). The electromechanical base fuze performs in one of the following modes:

- Point detonating without delay (default mode).
- Point detonating with delay.
- Airburst detonating (time delay).

The multipurpose high explosive functions out to 4,000 meters and is capable of breaching a 3-inch by 50-inch hole in an 8-inch reinforced concrete wall with no more than 3 rounds. It will also defeat an earth and timber bunker with no more than 2 rounds when fired in delay mode. It is designed to defeat massed infantry from 80 to 4,000 meters—with 50 percent incapacitation versus a squad or a platoon—while in airburst

mode. While in airburst mode, the fuze incorporates a self-destruct function after approximately 15 seconds.

Antipersonnel Ammunition: M1028 Canister

The purpose of the M1028 round is to provide a short-range antipersonnel capability for the Abrams tank. The projectile houses 1,097 three-eighth-inch tungsten balls (see fig. F-6). This round is most effective at 200 to 500 meters against a standard 10-person infantry squad in a wedge formation.

Target Practice Ammunition

Target practice ammunition is used during gunnery training in place of service ammunition. The training rounds available for the M256 cannon are the M865 target practice cone stabilized discarding sabot-tracer, M831A1-TP-T, and M1002 target practice multipurpose-tracer. Additionally, the M1028 canister round has been approved for use on training ranges.

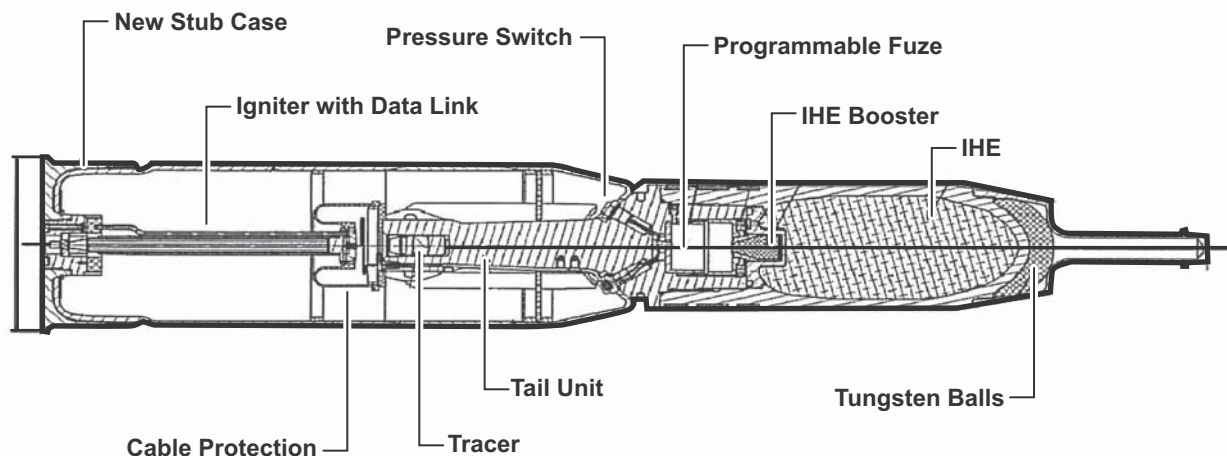

Legend

IHE improved high explosive

Figure F-5. 120-mm Multipurpose High Explosive.

M865 Target Practice Cone Stabilized Discarding Sabot-Tracer

The purpose of the M865 target practice cone stabilized discarding sabot-tracer is to simulate the M829 family service sabot round for gunnery training (see fig. F-7).

M1002 Target Practice Multipurpose-Tracer

The purpose of the M1002 target practice multi-purpose-tracer cartridge is to serve as a ground-mode only training round for the 120-mm HEAT multipurpose-tracer, M830A1 tactical cartridge (see fig. F-8 on page F-6).

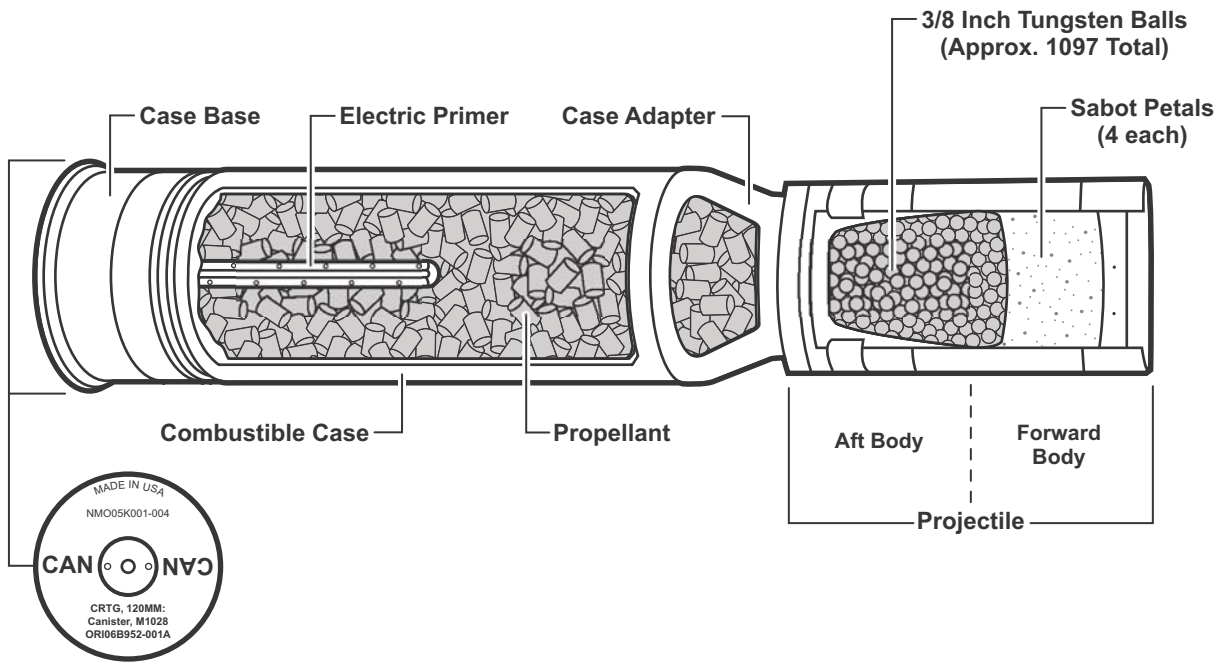

Figure F-6. M1028 Canister.

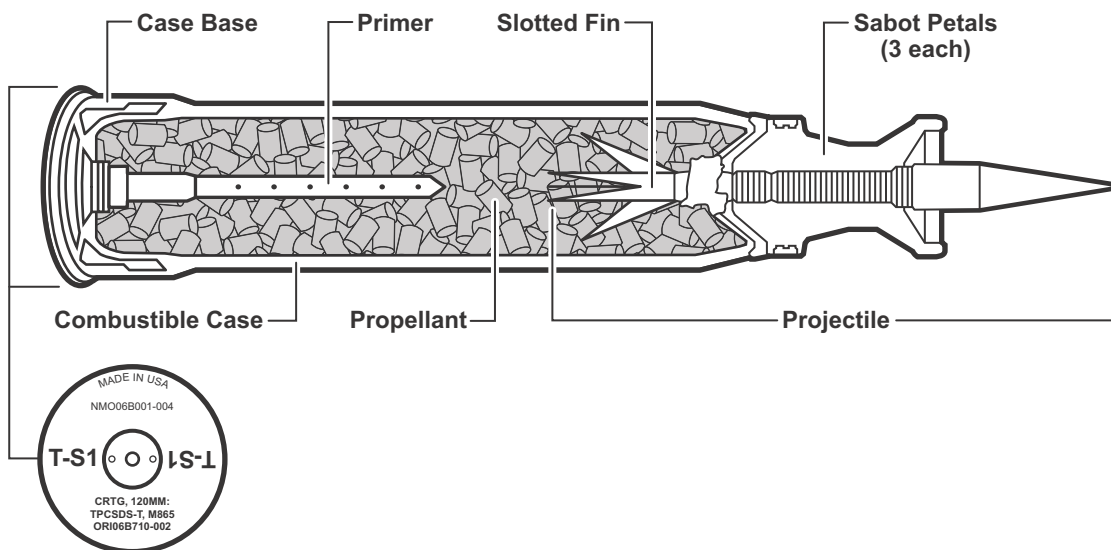

Figure F-7. M865 Target Practice Cone Stabilized Discarding Sabot-Tracer.

Danger of Discarding Projectile Components

All rounds that have discarding sabots—service kinetic energy rounds, M865, MPAT, and canister rounds—will not be fired over friendly troops unless those troops are protected by adequate cover. Troops might be struck by the discarded components.

Discarding Sabot Rounds

The danger area for rounds that have discarding sabots, such as service kinetic energy rounds, M865, and MPAT, extends to 1,000 meters from the gun and 70 meters to either side of the gun-target line (see fig. F-9).

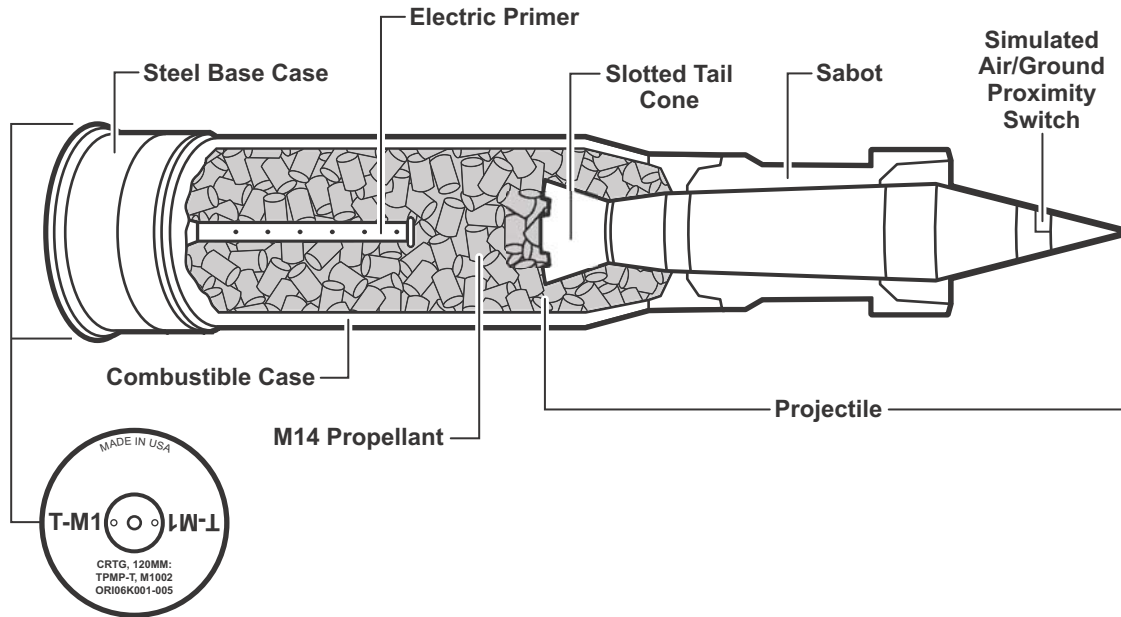

Figure F-8. M1002 Target Practice Multipurpose-Tracer.

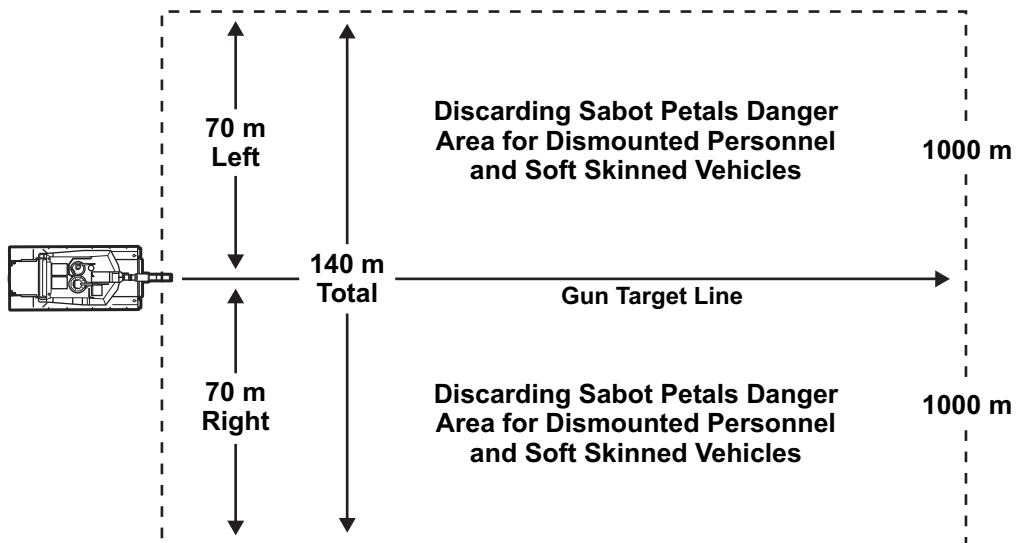

Figure F-9. Discarding Sabot Danger Area.

M1028 Canister Round

The danger area for the discarding components of the canister round is similar to those of any kinetic energy sabot round.

Smoke Grenades

Smoke grenades are primarily used to provide concealment for combat vehicles and personnel on the ground. They can also be used to provide signaling for events and other follow-on elements. The M257 smoke grenade launcher contains eight smoke grenades in each launcher set that, when fired, can cover an arc of 104 degrees in front of the turret.

The patterns shown in figure F-10 display the most common configuration for the smoke grenade launchers.

—DANGER—

The hatches should be closed when firing the smoke grenade launchers to prevent red phosphorus, which can cause serious burns, from being blown in on the crew. All personnel outside the vehicle must stay at least 150 meters from the vehicle during firing.

Each grenade has a specific functioning area once it is discharged from the launcher. Figure F-11, on page F-8, illustrates the grenade functioning area based on the respective vehicle launcher array. Although each grenade is designed to function at 30 meters from the launcher, each pyrotechnic requires an additional 8 meters to fully ignite and provide screening. Figure F-11, on page F-8, represents the hazard dimensions for all platforms launching the L8 series, M76, or M82 smoke grenades from a vehicle. It shows the worst case distances as crews may have multiple grenade types prepared.

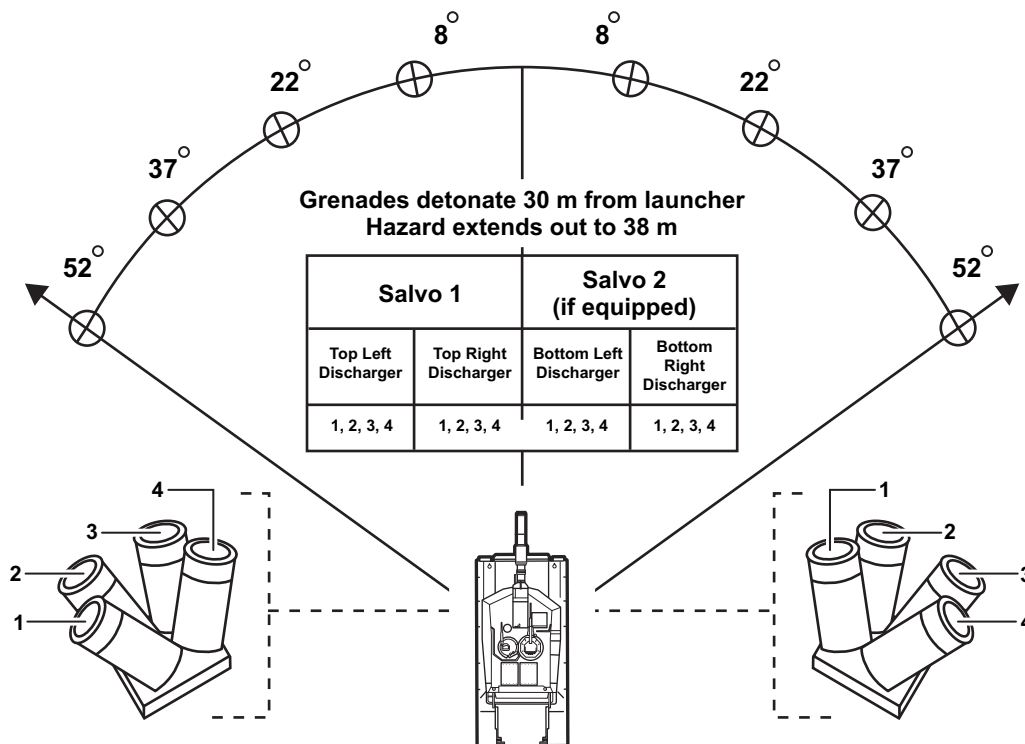

Figure F-10. Salvo Pattern for the M257 Smoke Grenade Launcher System.

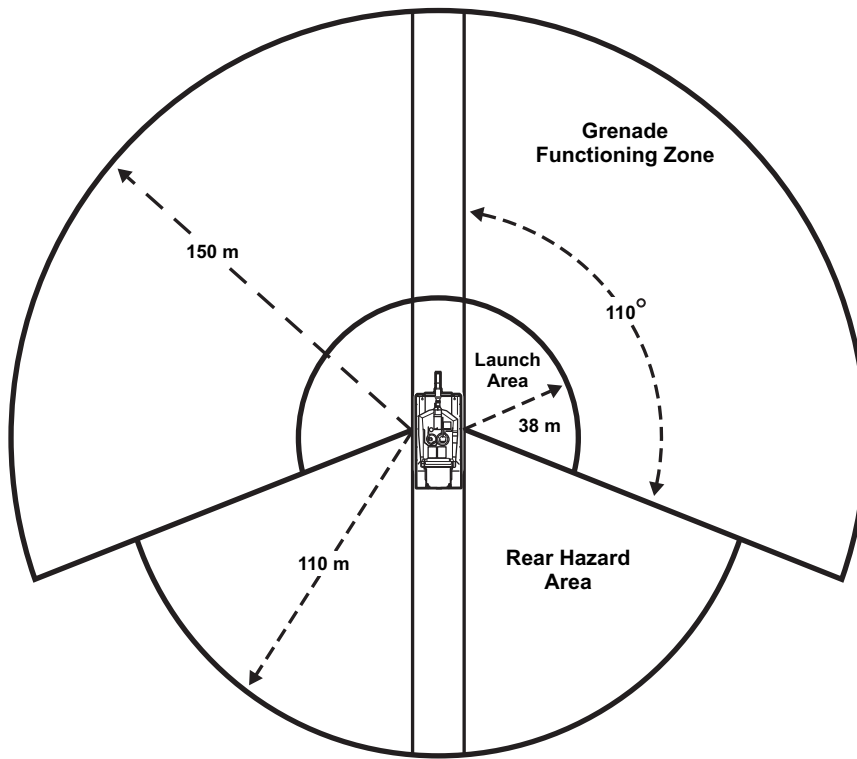

Figure F-11. Smoke Grenade Composite Hazard Area.

GLOSSARY

SECTION I. ACRONYMS

AAV	amphibious assault vehicle	LCAC	landing craft, air cushion
ABV	assault breacher vehicle	LCU	landing craft, utility
APFSDS-T	armor-piercing, fin-stabilized, discarding sabot-tracer	MAGTF	Marine air-ground task force
AVLB	armored vehicle-launched bridge	MCWP	Marine Corps warfighting publication
CBRN	chemical, biological, radiological, and nuclear	METT-T	mission, enemy, terrain and weather, troops and support available-time available
CSS	combat service support	MICLIC	mine clearing line charge
FAC	forward air controller	MLC	military load classification
FST	fire support team	mm	millimeter
FTL	far target location	MOUT	military operations on urbanized terrain
GCE	ground combat element	MPAT	multipurpose antitank
HEAT	high explosive antitank	mph	miles per hour
HMMWV	high mobility multipurpose wheeled vehicle	psi	pounds per square inch
in	inch	ROE	rules of engagement
km	kilometer	S-4	logistics officer
kph	kilometers per hour	SOP	standing operating procedure
		VHF	very high frequency

SECTION II. DEFINITIONS

avenue of approach—An air or ground route of an attacking force of a given size leading to its objective or to key terrain in its path. Also called **AA**. (JP 1-02)

axis of advance—A line of advance assigned for purposes of control; often a road or a group of roads, or a designated series of locations, extending in the direction of the enemy. (JP 1-02)

ballistic trajectory—The trajectory traced after the propulsive force is terminated and the body is acted upon only by gravity and aerodynamic drag. (JP 1-02)

basic load (ammunition)—The quantity of supplies required to be on hand within, and which can be moved by, a unit or formation. It is expressed according to the wartime organization of the unit or formation and maintained at the prescribed levels. (JP 1-02)

battle position—1. In ground operations, a defensive location oriented on an enemy avenue of approach from which a unit may defend. 2. In air operations, an airspace coordination area containing firing points for attack helicopters. Also called **BP**. (MCRP 5-12C)

coaxial machine gun—A machine gun mounted in the turret of a tank in a way that its line of fire is parallel (coaxial) to that of the cannon set on the same mounting.

command post—A unit's or subunit's headquarters where the commander and the staff perform their activities. In combat, a unit's or subunit's headquarters is often divided into echelons; the echelon in which the unit or subunit commander is located or from which such commander operates is called a command post. Also called **CP**. (MCRP 5-12A)

company team—A combined arms organization formed by attaching one or more nonorganic

tank, mechanized infantry, or light infantry platoons to a tank, mechanized infantry, or light infantry company either in exchange for or in addition to organic platoons. (MCRP 5-12A)

concealment—The protection from observation or surveillance. (MCRP 5-12A)

cover—Shelter or protection, either natural or artificial. (MCRP 5-12A, part 4 of a 6 part definition)

covering force—1. A force operating apart from the main force for the purpose of intercepting, engaging, delaying, disorganizing, and deceiving the enemy before the enemy can attack the force covered. 2. Any body or detachment of troops which provides security for a larger force by observation, reconnaissance, attack, or defense, or by any combination of these methods. (JP 1-02)

dead space—1. An area within the maximum range of a weapon, radar, or observer, which cannot be covered by fire or observation from a particular position because of intervening obstacles, the nature of the ground, or the characteristics of the ballistic trajectory, or the limitations of the pointing capabilities of the weapon. 2. An area or zone which is within range of a radio transmitter, but in which a signal is not received. 3. The volume of space above and around a gun or guided missile system into which it cannot fire because of mechanical or electronic limitations. (JP 1-02)

defilade—Protection from hostile observation and fire provided by an obstacle such as a hill, ridge, or bank. (JP 1-02, part 1 of a 3 part definition)

direct fire—Fire delivered on a target using the target itself as a point of aim for either the weapon or the director. (JP 1-02)

elevation—The vertical distance of a point or level on or affixed to the surface of the Earth measured from mean sea level. (JP 1-02)

fire support—Fires that directly support land, maritime, amphibious, and special operations forces to engage enemy forces, combat formations, and facilities in pursuit of tactical and operational objectives. (JP 1-02) Assistance to elements of the Marine air-ground task force engaged with the enemy rendered by other firing units, including (but not limited to) artillery, mortars, naval surface fire support, and offensive air support. (MCRP 5-12C)

fuze—A device which initiates an explosive train. (MCRP 5-12A)

hide—The positioning of a vehicle, individual, or unit so that no part is exposed to observation or direct fire. (MCRP 5-12A)

hull down—The positioning of an armored vehicle so that the muzzle of the gun or launcher is the lowest part of the vehicle exposed to the front. Hull down positions afford maximum protection for vehicles that are engaging targets with direct fire. (MCRP 5-12A)

identification—The process of determining the friendly or hostile character of an unknown detected contact. Also called **ID**. (JP 1-02, part 1 of a 3 part definition)

indirect fire—Fire delivered on a target that is not itself used as a point of aim for the weapons or the director. (JP 1-02)

kinetic energy ammunition—The primary armor-defeating round for the 120-mm main gun and the most accurate of all tank ammunition. Kinetic energy is a combination of mass (weight) and velocity (speed) of the projectile; no explosives are needed to penetrate the target. (MCWP 3-12.2)

laser—Any device that can produce or amplify optical radiation primarily by the process of controlled stimulated emission. A laser may emit electromagnetic radiation from the ultraviolet portion of the spectrum through the infrared

portion. Also, an acronym for “light amplification by stimulated emission of radiation.” (JP 1-02)

line of sight—The unobstructed path from a soldier, weapon, weapon sight, electronic-sending and -receiving antennas, or piece of reconnaissance equipment to another point. Also called **LOS**. (MCRP 5-12A)

military operations on urbanized terrain—All military actions that are planned and conducted on a topographical complex and its adjacent natural terrain where manmade construction is the dominant feature. It includes combat in cities, which is that portion of military operations on urbanized terrain involving house-to-house and street-by-street fighting in towns and cities. Also called **MOU**. (MCRP 5-12C)

obscuration—The effects of weather, battlefield dust, and debris, or the use of smoke munitions to hamper observation and target-acquisition capability or to conceal activities or movement. (MCRP 5-12A)

obstacle—Any obstruction designed or employed to disrupt, fix, turn, or block the movement of an opposing force, and to impose additional losses in personnel, time, and equipment on the opposing force. Obstacles can exist naturally or can be man-made, or can be a combination of both. (JP 1-02)

point target—1. A target of such small dimension that it requires the accurate placement of ordnance in order to neutralize or destroy it. 2. A target in which the ratio of radius of damage to target radius is equal to or greater than 5. (MCRP 5-12A)

pyrotechnic—A mixture of chemicals which, when ignited, is capable of reacting exothermically to produce light, heat, smoke, sound, or gas. (MCRP 5-12A)

reconnaissance—A mission undertaken to obtain, by visual observation or other detection methods, information about the activities and

resources of an enemy or adversary, or to secure data concerning the meteorological, hydrographic, or geographic characteristics of a particular area. Also called **RECON**. (JP 1-02)

reconnaissance by fire—A method of reconnaissance in which fire is placed on a suspected enemy position to cause the enemy to disclose a presence by movement or return of fire. (MCRP 5-12A)

sabot—A lightweight carrier in which a subcaliber projectile is centered to permit firing the projectile in the larger caliber weapon. The carrier fills the bore of the weapon from which the projectile is fired; it is normally discarded a short distance from the muzzle.

stability operations—An overarching term encompassing various military missions, tasks, and activities conducted outside the United States in coordination with other instruments of national power to maintain or reestablish a safe and secure environment, provide essential governmental

services, emergency infrastructure reconstruction, and humanitarian relief. (JP 1-02)

suppressive fire—Fires on or about a weapons system to degrade its performance below the level needed to fulfill its mission objectives, during the conduct of the fire mission. (JP 1-02)

target acquisition—The detection, identification, and location of a target in sufficient detail to permit the effective employment of weapons. Also called **TA**. (JP 1-02)

wingman—One of two tanks in a section, normally the subordinate tank in the platoon leader's or platoon sergeant's section. Under battlefield conditions, the wingman concept facilitates control of the platoon when it operates in sections. The concept requires that one tank orient on another tank on either its left or right side. In the absence of specific instructions, wingmen move, stop, and shoot when their leaders do.

REFERENCES

Army Field Manual (FM)

4-30.3 Maintenance Operations and Procedures

Marine Corps Publications

Marine Corps Doctrinal Publication (MCDP)

1-0 Marine Corps Operations

Marine Corps Warfighting Publications (MCWPs)

3-17.8 Combined Arms Mobility Operations

3-33.3 Marine Corps Public Affairs

3-35.1 Mountain Warfare Operations (under development)

3-35.5 Jungle Operations

3-35.6 Desert Operations

3-37.3 Multiservice Tactics, Techniques, and Procedures for Chemical, Biological, Radiological, and Nuclear Decontamination

Marine Corps Reference Publications (MCRPs)

3-31B Amphibious Ships and Landing Craft Data Book

4-11.3H Multiservice Tactics, Techniques, and Procedures for Tactical Convoy Operations Handbook

Marine Corps Interim Publication (MCIP)

3-35.01 Tactics, Techniques, and Procedures (TTP) for Reduction of Urban Area Strongpoints

Marine Corps Technical Manual (TM)

08953A-10 Tank M1A1 (120-mm Gun)

American, British, Canadian, Australian (ABCA) Armies Standardization Program

573 Tactical Hand and Arm Signals for the Control of AFVs

1073 Common Critical Alert and Weapon States for Direct Fire Weapon Systems

1074 Fire Control Procedures for Direct Fire Weapon Systems

1078 Common Format for the Reporting of the Effects of Direct Fire Support

1225 Common Critical Planning Procedures for the Employment of Direct Fire Weapon Systems

1226 Common Critical Procedures for Checking Friendly Fire

This Page Intentionally Left Blank

To Our Readers

Changes: Readers of this publication are encouraged to submit suggestions and changes to Doctrine Control Branch via e-mail: doctrine@usmc.mil.

Suggestions and changes must include the following information:

- Location of change
 - Publication number and title
 - Current page number
 - Paragraph number (if applicable)
 - Line number
 - Figure or table number (if applicable)
- Nature of change
 - Addition/deletion of text
 - Proposed new text

Additional copies: If this publication is not an electronic only distribution, a printed copy may be obtained from Marine Corps Logistics Base, Albany, GA 31704-5001, by following the instructions in MCBul 5600, *Marine Corps Doctrinal Publications Status*. An electronic copy may be obtained from the United States Marine Corps Doctrine web page:

<https://homeport.usmc.mil/sites/mcdoctrine/SitePages/Home.aspx>