

NATO/PfP UNCLASSIFIED

**ALLIED
ENGINEERING
PUBLICATION**

**AEP-55, Volume 1
(Edition 1)**



**PROCEDURES FOR EVALUATING THE
PROTECTION LEVEL OF LOGISTIC AND
LIGHT ARMoured VEHICLES**

VOLUME 1

FEBRUARY 2005

NATO/PfP UNCLASSIFIED

NORTH ATLANTIC TREATY ORGANIZATION
NATO STANDARDIZATION AGENCY (NSA)
NATO LETTER OF PROMULGATION

February 2005

1. AEP-55, Volume 1 (Edition 1) - "PROCEDURES FOR EVALUATING THE PROTECTION LEVEL OF LOGISTIC AND LIGHT ARMoured VEHICLES" is a NATO/PfP UNCLASSIFIED publication.
2. AEP-55, Volume 1 (Edition 1) is effective on receipt.

J. MAJ 
Brigadier General, POL(AR)
Director NSA

AEP-55, Volume 1
(Edition 1)

NATION	SPECIFICATION RESERVATIONS

RECORD OF CHANGES

Change Date	Date Entered	Effective Date	By Whom Entered

TABLE OF CONTENTS

NATO LETTER OF PROMULGATION	I
SPECIFICATION RESERVATIONS	II
RECORD OF CHANGES	III
TABLE OF CONTENTS	IV
ABBREVIATION LIST	VI
1. SCOPE	1
2. SIGNIFICANCE AND USE	1
3. SYSTEM ACCEPTANCE PROCESS	2
3.1 Overview	2
3.2 Scoping of acceptance test activities	2
3.3 Phase 1: Test plan definition	3
3.3.1 Overview	3
3.3.2 Ballistic test requirements and planning / component selection.....	3
3.3.3 Vehicle target descriptions.....	6
3.3.4 Vehicle armour area descriptions	6
3.3.5 Number of shots required for ballistic assessment	8
3.4 Phase 2: Main Areas ballistic evaluation	9
3.5 Phase 3: Structural Weak Area and Excluded Zone vulnerability evaluation	10
3.6 Phase 4: Vulnerable Area evaluation	10
3.6.1 Vulnerable Area assessment.....	10
4. TEST EQUIPMENT	14
4.1 Test facility and arrangement	14
4.2 Launcher to target distance	15
4.3 Launching system	15
4.4 Projectiles	15
4.5 Projectile velocity measurement	16
4.6 Projectile yaw measurement and acceptance criteria	16
4.7 Impact location witness	16
4.8 Target types, retention method and orientation	17
4.9 Witness system.....	17
5. BALLISTIC TEST PROCEDURE FOR COMPONENT EVALUATION.....	18
5.1 Test range ambient conditions	18
5.2 Details and marking of targets.....	18
5.3 Hit location and number.....	19
5.4 Target conditioning.....	19
5.5 Target positioning and obliquity measurement	20
5.6 Test impact validity assessment	20
5.7 Witness plate and armour examination.....	22
5.8 Component performance determination	22
5.9 Ballistic test report	23

ANNEX A - TEST CONDITIONS AND PROJECTILES A-24

ANNEX B - MULTIPLE HIT TESTINGB-1

ANNEX C - ARTILLERY THREAT C-1

ANNEX D - SHATTER GAP TESTING..... D-1

ANNEX E - TEST EQUIPMENT ISSUESE-1

ANNEX F - FLOW CHART SUMMARY OF THE TESTING AND ACCEPTANCE PROCESS..... F-1

ANNEX G - OPTIONS FOR BALLISTIC PERFORMANCE EVALUATION..... G-1

ANNEX H - DEFINITIONS H-1

ANNEX I - REFERENCES – RELATED DOCUMENTS.....I-1

AEP-55, Volume 1
(Edition 1)

ABBREVIATION LIST

A _U	Unprotected (vulnerable) Area
A _P	Protected Area
A _o	Threatened Area (occupant compartment)
CP	Complete Penetration
EPC	Expected Protection Capability
EZ	Excluded Zone
FSP	Fragment Simulating Projectile
HE	High Explosive
KE	Kinetic Energy
LAV	Light Armoured Vehicle
LWA	Localized Weak Area
NA	National Authority
MA	Main Area
PP	Partial Penetration
RH	Relative Humidity
RVA	Relative Vulnerable Area
STANAG	Standardization Agreement (NATO)
SWA	Structural Weak Area
VA	Vulnerable Area

ALLIED ENGINEERING PUBLICATION

PROCEDURES FOR EVALUATING THE PROTECTION LEVELS OF LOGISTIC AND LIGHT ARMoured VEHICLES FOR KE AND ARTILLERY THREATS

1. SCOPE

This AEP describes the system qualification and acceptance procedure for determining the Protection Level of logistic and light armoured vehicles (LAV) for KE and artillery threats. The threats to be considered are small and medium calibre kinetic energy (KE) ballistic projectiles and fragment simulating penetrators (FSP) representing artillery shell fragments, as defined in STANAG 4569 Annex A (summarised in Annex A of the AEP-55).

This process includes standard techniques and reproducible test procedures for evaluating the ballistic resistance of vehicle armour components (integral, add-on, opaque and transparent) as well as the required vehicle Vulnerable Area assessment.

Where stated in this document, the National Authority (NA) is an appointed expert.

The qualification and acceptance testing of mine protection will be covered in a future publication.

2. SIGNIFICANCE AND USE

The ballistic procedures described in this document apply equally for ballistic tests on various target systems including single target plates, fully engineered targets and vehicle targets (whole or sections). The Protection Level of logistic vehicles and LAV shall however be determined using acceptance tests performed on any component provided they are fully representative of the armour system used on the vehicle and the protection assessment uses the computation methodology provided.

The ballistic tests shall be carried out with the specified threat ammunition and under the impact conditions summarised in Annex A. The ballistic tests should be conducted at a test range approved by the National Authority. Test ranges may use in-house test facilities and equipment not covered by this document. The emphasis shall be placed on evaluating the potential weaknesses of the armour systems provided (worst case) as outlined in the document.

National Authorities may at their discretion accept any deviation from the procedures outlined in this AEP, provided the procedures used are judged equivalent and are well documented. An example is where vehicle protection systems have been assessed using the V50 methodology. When equivalent procedures are used, vehicle Protection Levels will be classified as "Estimated".

In the event of a conflict between the text of this document and the references cited herein, the text of this document takes precedence. Nothing in this document, however, supersedes applicable national laws and regulations unless a specific exemption has been obtained.

The evaluation of a product using these test procedures may require the use of materials and/or equipment that could be hazardous. This document does not purport to address all the safety aspects associated with their use. It is the responsibility of the organization using this specification to establish appropriate health and safety practices and to determine the applicability of any regulatory requirements prior to its use.

AEP-55, Volume 1
(Edition 1)

Unique requirements for the ballistic testing of specific end-items not covered in this document should be defined within the National procurement specification.

This AEP does not limit the threats that a National Authority may specify for vehicle armour testing. Additional ballistic projectiles potentially a threat to a vehicle may be specified but their inclusion is outside the scope of STANAG 4569.

This procedure may be updated as further data becomes available.

3. SYSTEM ACCEPTANCE PROCESS

3.1 Overview

Categorizing logistic vehicles or LAVs into specific Protection Levels is based simply on establishing the relative areas of the vehicle armour system that either meet or fail the specified ballistic threat Level protection requirements. From these relative values the unprotected Vulnerable Area (VA) may be calculated and judged against the minimum requirement of 90% vehicle area protection coverage indicated within the STANAG.

Ballistic testing is predicated on the proof velocity (V_{proof}) approach whereby a statistically-based number of KE threat rounds are fired at targets representative of the armour, the absence of perforation indicating that the desired immunity level of protection has been achieved. Ballistic failures are usually associated with areas of the armour where a weakness exists or has been introduced, e.g. unprotected welded joints in metallic plates and the influence of the welding process on material properties (heat affected zones). These potentially vulnerable areas are termed structural weak areas (SWAs). The presence (or absence) and extent of VA usually effectively determines whether the required vehicle protection coverage level of 90% is achieved.

The vehicle ballistic protection requirements also include an assessment of the capability of the armour system to withstand multiple shot impacts. This is achieved by firing the ballistic assessment rounds at predetermined separations and patterns. This unique multi-hit test methodology was developed following the detailed analysis of experimental trials involving burst fire attack of vehicles in representative and realistic engagement scenarios.

A limited amount of testing with FSP is also included in the vehicle assessment so that the effects of HE (High Explosive) shell fragmentation are addressed in the vehicle armour design. No multi-hit testing is required using FSPs.

The ballistic tests that are required by the acceptance process should be performed following the specific procedures defined in Paras 3 and 5 and with the equipment described in Para 4.

The final VA assessment shall be conducted according to the procedure defined in Para 3.4. The acceptance criterion is an expected protection capability of 90%.

3.2 Scoping of acceptance test activities

The complete acceptance process used to establish the Protection Level of a defined vehicular protection system consists of four sequential phases:

- Phase 1. Test plan definition.
- Phase 2. Main Areas ballistic evaluation.
- Phase 3. Structural Weak Areas ballistic evaluation.

Phase 4. Vulnerable Area evaluation and protection assessment.

Each Phase is described in more detail within the following Paras with additional information provided to clarify the assessment process.

3.3 Phase 1: Test plan definition

3.3.1 Overview

Prior to the assessment commencing, the scope of ballistic testing shall be established. This is achieved through the following process.

1. Identify all potential targets based on the individual threat / vehicle armour system geometric combinations or location of different ballistic resistance. This is to include the Main Areas of the armour system and any SWA (e.g. door panel interfaces, welded joints etc).
2. Minimise the extent of testing by grouping threats / geometries of ballistic equivalence and select a representative target undergo ballistic evaluation.
3. Calculate the number of targets and material requirements to carry out the tests identified.

The global test plan shall be prepared according to the method defined in Para 3.3.2 and the ballistic evaluation Phases and number of rounds mentioned in Para 3.3.5.

At the planning Phase, a nomenclature should be established to uniquely and simply identify the test series, threat, components, target and ballistic impact.

The resulting test, target and threat matrix should be agreed with the National Authority and remain the reference document covering the scope of ballistic testing prior to any testing being carried out.

3.3.2 Ballistic test requirements and planning / component selection

The component ballistic acceptance tests in Phases 2 and 3 shall be conducted using the projectiles, impact velocities and vehicle attack angles as defined in Annex A.

The component ballistic evaluations in Phases 2 and 3 employing the V_{proof} test shall be based on the principle of keeping the projectile impact velocity and impact angle constant within prescribed limits during a test series and these values shall be selected in Phase 1.

The KE threat ballistic resistance testing for Main Areas and SWA shall be in single hit or multi-hit mode according to Table 1. The details of the ballistic multi-hit requirements for all threat Levels are contained within Annex B. If the National Authority requires shatter-gap testing this should be considered at Phase 2.

Table 1 - Ballistic test assessment requirements for Phase 2 and 3

Ballistic test Phase	STANAG V_{proof} test requirements			
	KE bullet threat		KE fragment threat	
	Main Areas	Structural Weak Areas	Main Areas	Structural Weak Areas
Phase 2	Multi-hit tests	--	Single hit tests	--
Phase 3	--	Single hit tests	--	Single hit tests

AEP-55, Volume 1
(Edition 1)

Ballistic testing of components in Phase 2 and 3 shall be conducted at the most severe impact condition allowable. Computation of this angle shall take into account the projectile attack direction in azimuth and elevation defined for each Protection Level as well as the inclination of the representative armour panel on the vehicle. Where attacks at compound angles are required, the details of calculation should be included in the test plan and test report.

Figure 1 illustrates the angles of vehicle attack specified in Annex A for all Protection Levels. Figure .2 demonstrates the determination of angles of impact for sloping plates on actual vehicles. The impact angle of the artillery threat may be established using the same methodology but applying 360° of azimuth and the elevation specified for each Protection Level defined in Annex A.

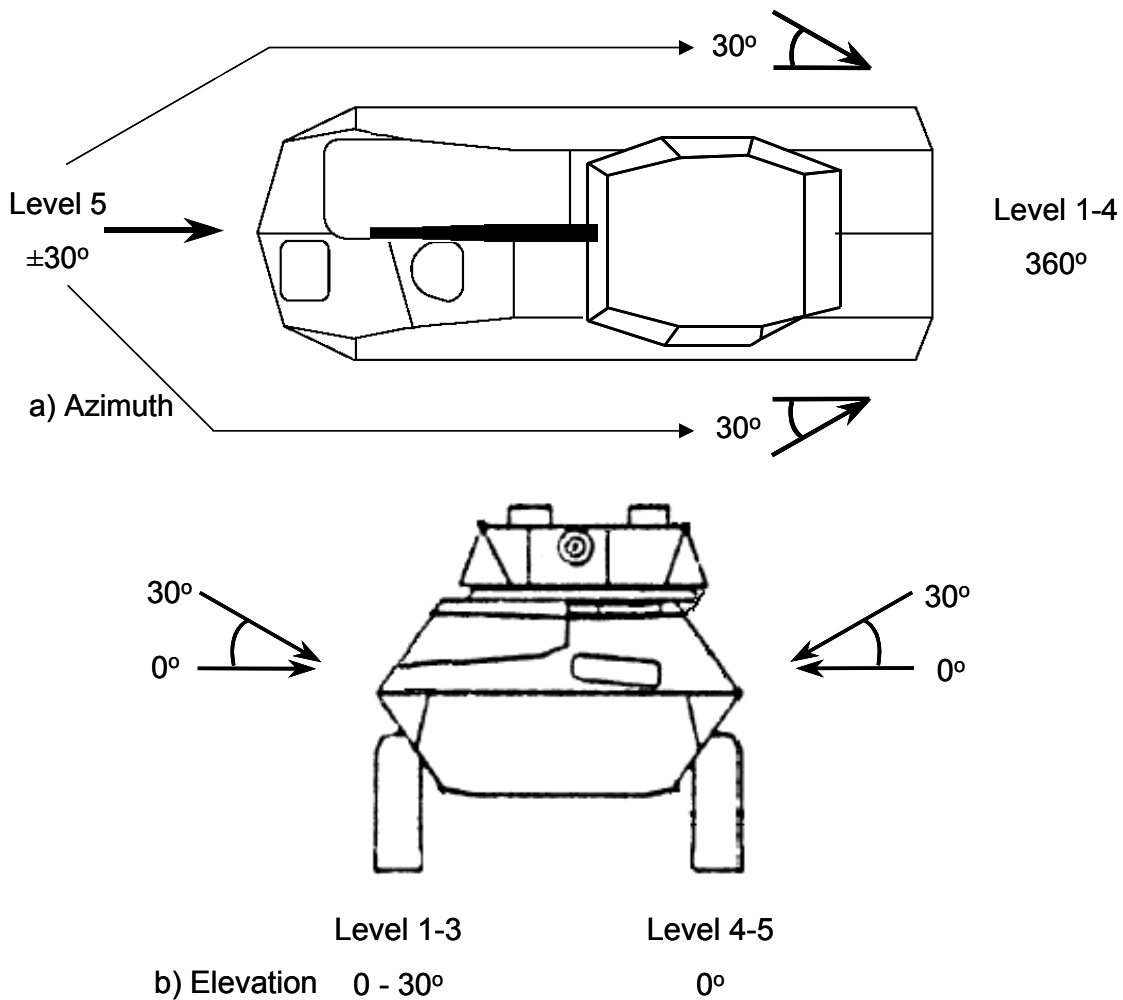
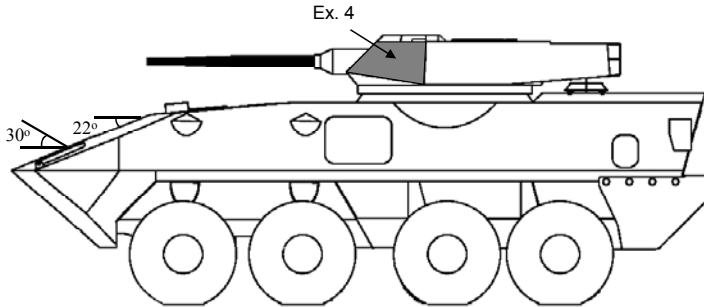

Figure 1 - Attack angles defined in Annex A for the KE Protection Levels

Example 1: KE Level 1-3

Angle of azimuth: 0°
 Maximum angle of elevation: 30°
 Angle of impact: $(90^\circ - 22^\circ) - 30^\circ = 38^\circ (> 0^\circ)$
 Testing angle of impact = worst case = 38°



Example 2: KE Level 1-3

Angle of azimuth: -90°
 Maximum angle of elevation: 30°
 Angle of impact: $(90^\circ - 70^\circ) - 30^\circ = -10^\circ (< 0^\circ)$
 Test angle of impact = worst case = 0°

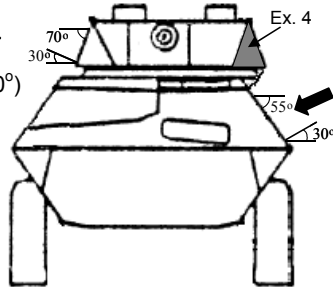

Example 3: KE Level 1-3

Angle of azimuth: 90°
 Maximum angle of elevation: 30°
 Angle of impact: $(90^\circ - 55^\circ) - 30^\circ = 5^\circ (> 0^\circ)$
 Testing angle of impact = worst case = 5°

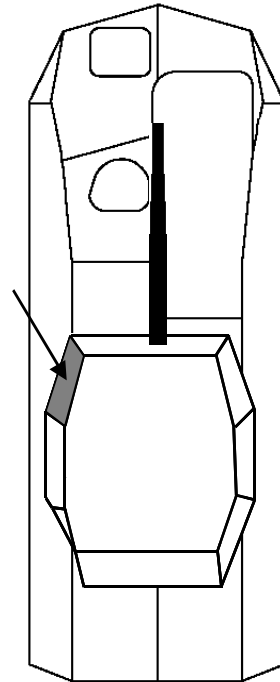
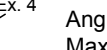

Example 4: KE Level 5 (Grey panel):

Orientation: 73° in azimuth; 25° in elevation

Level 5 (Appendix 1 angle: azimuth $\pm 30^\circ$; elev. 0°)
 Worst angle of azimuth: 30° {since $73^\circ - 30^\circ = 43^\circ (> 0^\circ)$ }
 Worst angle of elevation: 0°
 Test angle of impact: $\arctan \sqrt{\tan^2(25^\circ - 0^\circ) + \tan^2(73^\circ - 30^\circ)} = 46.2^\circ$

Includes

KE Level 4 (Appendix 1 angle: azimuth $0^\circ - 360^\circ$; elev. 0°)
 Worst angle of azimuth: 73°
 Worst angle of elevation: 0°
 Test angle of impact: 25° {since $73^\circ - 73^\circ = 0^\circ$ and $25^\circ - 0^\circ = 25^\circ$ }

and

KE Level 1-3 (Appendix 1 angle: azimuth $0^\circ - 360^\circ$; elev. $0^\circ - 30^\circ$)
 Worst angle of azimuth: 73°
 Worst angle of elevation: 25° {since $25^\circ - 30^\circ = -5^\circ (< 0^\circ)$ }
 Test angle of impact: 0°

Figure 2 - Method for determination of the testing angle of impact (worst angle of attack)

AEP-55, Volume 1
(Edition 1)

For a vehicle armour design to meet the requirements of a defined Protection Level it shall defeat all ammunition threats specified at that threat Level and those specified for any lower Protection Levels. Testing with projectiles specified for the lower Protection Levels will be necessary whenever there is reason to believe that the protection system may be vulnerable to such threats.

For many armours this requirement is automatically met since increasing Protection Level threats are usually more penetrative. An exception may occur with some geometric armour designs, for example perforated armour designed for 7.62 mm calibre bullets may demonstrate a weakness to smaller calibre or lower energy projectiles such as 5.56 mm. Hence this circumstance may represent more severe test conditions, and additional testing would need to be included in the test plan.

Components positioned outside the attack angle interval of one Protection Level, but inside the interval of a lower Level shall be tested at the Level of threat to which they are exposed. Table 2, derived from Annex A, illustrates the hierarchy of Protection Levels, the subordinate KE threats and their angles of attack to be considered.

Table 2 - Protection Level hierarchy indicating potential exposure to a lower Level threat

Protection Level being tested	Threat Level and test angle of attack to consider		
	5	4	3
5	Az: $\pm 30^\circ$; Elev: 0°	Az: 30° to 330° ; Elev: 0°	Az: 360° ; Elev: 0° to 30°
4	--	Az: 360° ; Elev: 0°	Az: 360° ; Elev: 0° to 30°
3	--	--	Az: 360° ; Elev: 0° to 30°

3.3.3 Vehicle target descriptions

Ballistics evaluation tests on vehicle protection systems may be performed on a variety of armour target types dependent on the objectives being sought. Single plate target and minimum engineered targets may be used for quality control of materials and basic assemblies or for R&D test firing on main armour areas to reduce the risk of failure on fully engineered or vehicle targets. Details of these target types are described within Para 4.8.

Only fully representative armour system targets shall be used for the component ballistic acceptance tests in Phase 2 and 3 as covered by this AEP through the use of fully engineered or vehicle targets.

3.3.4 Vehicle armour area descriptions

Fully engineered and vehicle targets contain a number of areas or zones that will be required to be considered and included within the ballistic assessment process at Phase 2 and 3 as they may critically influence the VA assessment within Phase 4. These armour areas are described below.

1. **Vehicle Main Areas (MA):** These are the relatively uniform vehicle armour panel areas that provide protection coverage against the specified ballistic threat Levels. However, these vehicle MAs may not be fully homogeneous in their protection and could contain zones of ballistic weakness as follows.
2. **Localized Weak Areas (LWA):** Where main armour systems are constructed from a combination of materials or rely on geometrical effects to defeat the threats, the protection provided may not be fully consistent over the full armour area. A typical example is the use of ceramic tiles in composite armour where tile joints may present an area of potential weakness. Where present, LWA are typically distributed throughout the MA.
3. **Structural Weak Areas (SWA):** Structural Weak Areas are larger main armour panel discontinuities that are potentially ballistically weak zones. Such areas are often unavoidable in the design or construction of a vehicle. SWA are generally edge oriented and not distributed throughout the MA. Classic examples are component interfaces (door / windows) and main panel intersections (welded joints and associated heat affected zones). Again, any testing within the SWA should exploit the LWAs.
4. **Excluded Zone (EZ):** When the testing of MAs is considered at Phase 2 it is essential that testing is not carried out within or be unduly influenced by the SWA. However, as there may be no *a priori* evidence for the size of the SWA that exists at the target boundary or around boltholes, an assumption has been made for the size of this zone. The nominated area around such features, initially excluded for the purposes of MA testing, is designated the Excluded Zone (EZ). This zone shall be tested in Phase 3 to validate if the EZ is ballistically resistant or if it is a VA. At the option of the National Authority, an assessment may be carried out in Phase 3 to determine the actual extent of the VA within or around the nominated EZ. Details of the EZ dimensions to be assumed are contained within Annex B, Table B 1.

Hence it is essential that the ballistic evaluation process includes the following aspects as further described in the relevant Paras of the Annex.

- Any performance assessment of the main armour areas in Phase 2 shall include the influence of any LWAs present but be outside the designated EZ containing the SWA.
- The performance of any SWAs shall be assessed in Phase 3 within the EZ and again shall include the influence of any LWAs present.

Figure 3 shows examples of how the definition of EZ is applied at different types of SWA. Figure 3 a) presents a welded plate lap joint. One discontinuity is found at the first edge of the plate and an EZ is defined on each side of this boundary. A second discontinuity is found at the boundary of the opposite edge, where EZs are applied as for the first case. It can be seen that the EZ do not overlap leaving a narrow non-EZ region at the centre. Since by definition every surface must be either an EZ or a MA, this thin zone is clearly a MA and shall be tested accordingly (see Paras 3.3.2 and 3.3.3). If the area is insufficiently large to allow a multi-hit assessment then testing should revert to single shot testing as applied to SWAs. Figure 3 b) shows the example of a rebated plate butt joint where the EZs are shown overlapping. In this case the whole area from point A to point B is tested as an EZ in Phase 3. Figure 3 c) presents an angled welded butt joint and in this case, the centre of the discontinuity is at the centre of the welded seam. The EZ then lies on each side of the weld, regardless of the actual extent of the heat-affected zone in the plate material, when unknown. For a cylindrical bolt fixing passing through a plate as illustrated in Figure C 3 d), the EZ is a circle of radius E described about the bolt centreline axis.

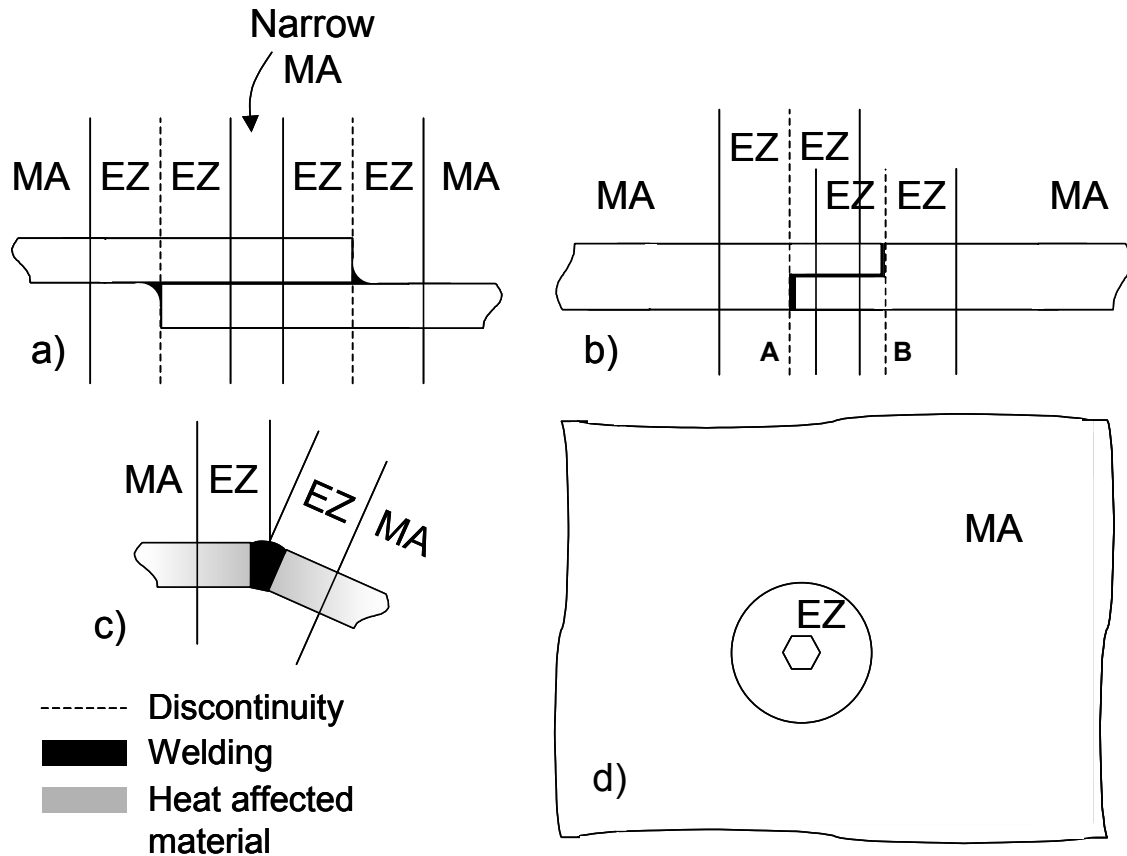

Figure 3 - Examples of generic SWA and the representative EZ

3.3.5 Number of shots required for ballistic assessment

Table 3 stipulates the specified number of accepted impacts of each projectile type and the armour configuration that shall be used to assess the KE and FSP ballistic Protection Levels 1 - 5. The table also demonstrates how the test Phases are aligned to these assessments. Refer also to Para 5.3 on impact location.

The following points should be noted:

1. An optional reduced number of shots indicated in parenthesis is available to National Authorities if during the initial portion of this testing the target back damage is judged to give full confidence that further rounds will produce no complete penetrations (CP).
2. The test requirements for SWAs are reduced compared to those of the MAs in recognition of the reduced area available and overall economics of the process.

This table should be read in connection with Table 1 on assessment methodology (single hit / multi-hit tests).

Table 3.- Minimum number of rounds for each projectile type and armour configuration

Phase	Objective	Target type	Number of shots			
			KE Level 1 - 3	KE Level 4	KE Level 5	FSP
1	Test plan to determine the representative panels and impact angles	Covers entire vehicle protection system	Not applicable			
2	Component MAs acceptance test to determine the ballistic resistance	Fully engineered and/or vehicle targets	22 (10*)	12 (6*)	12 (4*)	5
3	Component SWAs acceptance test to determine the ballistic resistance	Vehicle and/or fully engineered targets	10	5	3	3
4	VA assessment to determine system acceptance	Covers entire vehicle protection system	Not applicable			

* Could be reduced to 10 shots for Protection Levels 1 to 3, 6 shots for Protection Level 4 and 4 shots for Protection Level 5, if the Level of back surface damage is judged by National Authority to give full confidence that further rounds will produce no CP.

The acceptance criteria (FAIR / UNFAIR impact and target pass / fail) for the ballistic tests and the procedure for re-test should this be required are covered within Paras 5.6 and 5.7.

3.4 Phase 2: Main Areas ballistic evaluation

This is the main component acceptance test phase which shall be made with the threats and under the conditions specified in Annex A. Table 3 summarises the test requirements involved.

All assessments shall be made using either fully engineered targets or vehicle targets to determine the ballistic resistance of the main surfaces of the armour panels. These main surfaces may include LWAs. Where this is the case the impact locations selected should maximise the number of LWAs tested whilst meeting the geometric criteria defined for the multi-hit procedure (Annex B).

The ballistic threat testing employs the V_{proof} test methodology with integrated multi-hit evaluation.

For KE threat Levels 1 - 3 a minimum of 22 rounds with no CP is normally required.

For KE threats Levels 4 - 5 the minimum number of rounds is normally set to 12 in order to reduce the ammunition and target numbers required.

The artillery threat testing employs the V_{proof} test methodology using FSPs in single hit mode (impacts spaced so as not to influence one another) with no requirement for multi-hit testing.

For artillery Protection Levels 1 to 3, testing is not required but may be specified by the National Authority using 12.7 mm or 20 mm FSPs (see Annex C).

For artillery Protection Levels 4 and 5, testing is mandatory using the 20 mm FSP and a minimum of 5 rounds with no CP is required.

Component target performance determination is assessed according to Para 5.8.

Shatter gap testing if required by the National Authority is also carried out in Phase 2 (see Annex D).

AEP-55, Volume 1
(Edition 1)

Additionally, the ballistic resistance of targets that have been exposed to environmental test conditions (e.g. vibration, temperature / humidity tests) is optional, but could be included at the discretion of the National Authority.

In the event of CP, the options for re-test are described in Para 5.8. A vehicle can still pass the system acceptance evaluation in Phase 4 if the area represented by the totality of the failed components identified in Phase 2 and 3 is below the 10% threshold as calculated by the approved method described in Para 3.6.1.

3.5 Phase 3: Structural Weak Area and Excluded Zone vulnerability evaluation

During this Phase evaluation of targets containing potential SWA is carried out by testing the EZ with single shot impacts for both the ballistic and FSP threats identified in Annex A. A reduced level of testing is required compared to MA targets. The nominated size of the EZ is related to the Protection Level (and ammunition calibre) as indicated in Annex B.

Vehicle targets are the best target samples for SWA evaluation. Fully engineered targets may be used as long as the SWA are constructed in the exact same manner as for the actual vehicle.

SWAs are only potentially vulnerable but are often the critical areas of a LAV. The aims of the Phase 3 testing on representative armour targets are therefore a combination of the following activities:

- To evaluate the ballistic resistance of the EZ.
- To detect the presence of VA within SWA and then, at the National Authority discretion, to determine the extent of the VA.

In the event of CP, the options for re-test are described in Para 5.8. A vehicle can still pass the system acceptance evaluation in Phase 4 if the area represented by the totality of the failed components identified in Phase 2 and 3 is below the 10% threshold as calculated by the approved method described in Para 3.6.1.

3.6 Phase 4: Vulnerable Area evaluation

The effective area of vehicle Protection Level coverage is the ultimate system acceptance criterion. By computing the tests results of all component acceptance tests of Phases 2 and 3, the total surface area of components sentenced as offering zero ballistic resistance is determined. If this surface area is lower than 10% for all aspect angles, the protection system is accepted. If there is no failed component in Phases 2 and 3 and there is no unprotected area included in the protection system design, the protection system is then automatically accepted. The details of the VA assessment calculation and analysis are covered within the following Para 3.6.1.

The 90% expected protection capability shall be provided for every aspect angle that results from the combination of the azimuth and elevation angles specified in Annex A. The basis of this calculation shall be confirmed experimentally by testing with each projectile type at the defined KE Protection Level (stated and below).

3.6.1 Vulnerable Area assessment

The protection system acceptance Phase 4 is based on a simplified vulnerability analysis called a Vulnerable Area (VA) assessment. The assumption leading to simplification is that the protection system should perform to ensure that in 90% of occurrences no projectile could enter the occupant compartment of a vehicle, even if the projectile's path does not cross the position of an occupant. In other words, the VA assessment assumptions are:

1. A CP of a crew / passengers compartment is defined as a failure of the protective system;
2. The expected protection capability shall be attained for all aspect angles specified within the azimuth / elevation requirements (Annex A). The component that succeeded to its most severe impact angle is assumed to resist at the other impact angles represented by the aspect angles of the VA evaluation.
3. Component probability of hit is to be interpreted as a probability given a hit on the occupant compartment protection system. No account is taken of munitions dispersion or aiming effects.
4. The vehicle is sufficiently far from the weapon to consider that all presented area regions are equally probable of being hit and that all shots potentially hitting the vehicle are essentially parallel.

Theoretically, the expected protection capability (EPC) is defined as the summation, for all components, of the probability of hitting the component multiplied by the probability that this component resists the impact. The term "component" as used above is defined as parts of the protection system, i.e. major armour panels or SWAs, and not functional component as the term is generally used in system vulnerability analysis. The probability of hitting an armour component is proportional to the projected area of the component onto the plane perpendicular to the direction of the threat. For the purpose of the VA assessment method, it is assumed that all components that successfully pass the ballistic evaluation tests during Phases 2 and 3, for the given Levels threats and conditions defined in Annex A achieve a 100% probability to defeat this threat. The components that fail Phases 2 or 3 are assumed to be defeated with a 100% probability given a hit, i.e. are certain to be perforated if hit. The EPC can then be defined as the ratio of the protected area (A_P) to the threatened area (A_O):

$$EPC = 100\% * \frac{A_P}{A_O}$$

The Relative Vulnerable Area (RVA) is defined as ratio of the unprotected (vulnerable) area (A_U) to area A_O :

$$RVA = 100\% * \frac{A_U}{A_O} = 100\% - EPC$$

Area A_O is derived from the parallel projection of the occupant compartment onto the plane perpendicular to the direction of the threat. Area A_P is that proportion of area A_O for which the protection is ensured with respect to the direction of the threat. In contrast, area A_U is that proportion of area A_O for which there is no protection with respect to the direction of the threat.

AEP-55, Volume 1
(Edition 1)

To assess the RVA, a series of views representing the assembled armour personnel compartment (not the entire vehicle) should be produced for analysis. These can be three dimensional computer-generated plots, or hand drawn views. Figure 4 shows an example for a 0° and 90° of azimuth (front view and side view respectively), where the crew compartment is represented by dotted lines. The projected surface area of the crew compartment could be calculated as well as the projected surface area of the vulnerable zones.

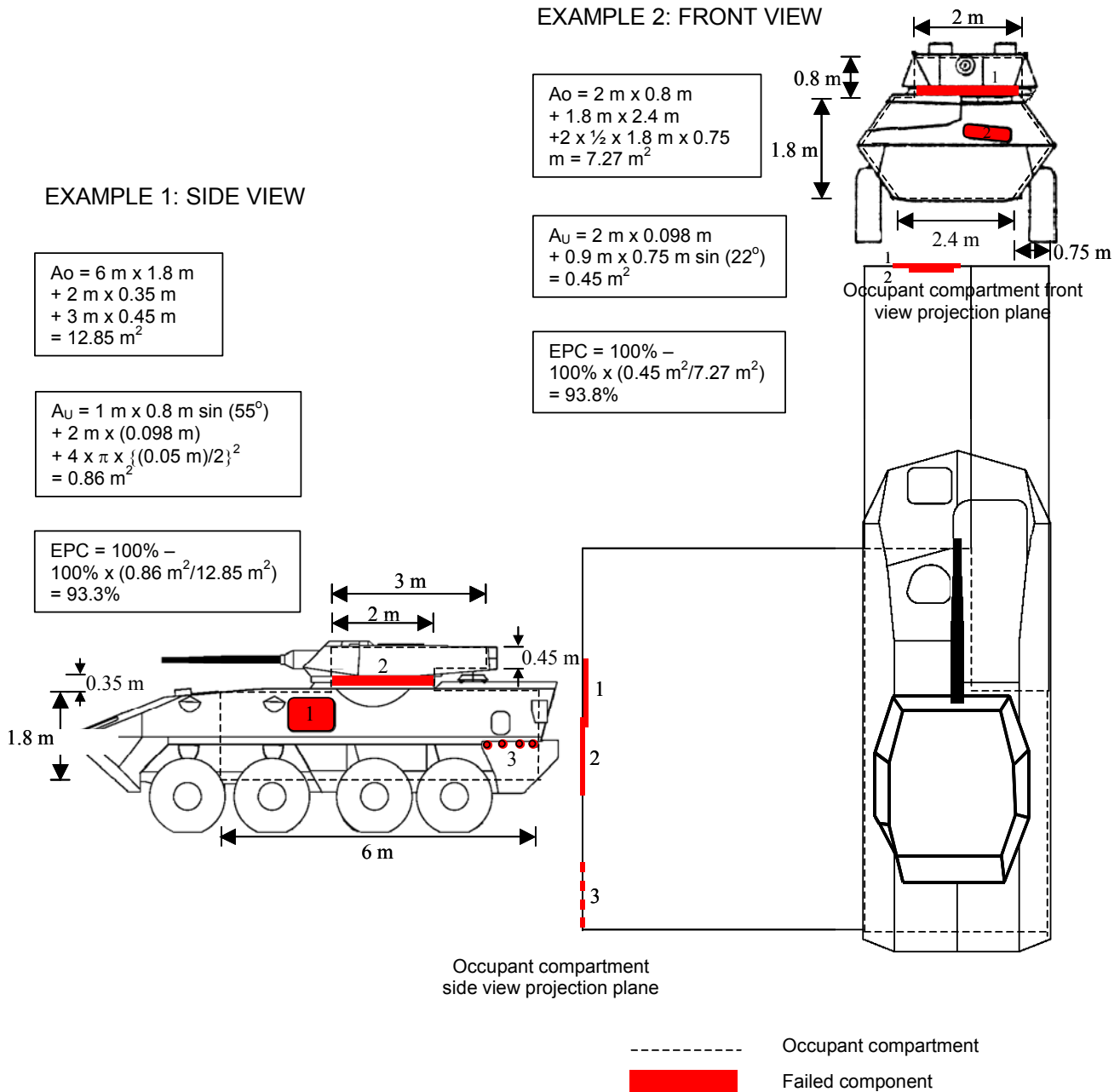

Figure 4 – Example of Vulnerable Area assessment method

For a major armour panel component that failed the testing procedure in Phase 2, the surface area considered as vulnerable corresponds to the presented areas of the component, i.e. excluding the EZ. On the side view of the example in Figure 4, failed component 1 has an actual area 1 m by 0.8 m = 0.8 m² but the projected area to consider in the VA calculation is 1 m x 0.655 m = 0.655 m² since it is in a 55° plane, which give a projected dimension of 0.8 m sin (55°) = 0.655 m.

For a component tested in Phase 3 (SWA evaluation), the surface area considered as vulnerable after a failure depends on the geometry of the weak area. For linear weak zones such as welds, overlaps or edges, the width of the VA is considered by default as being the width of the EZ representing the SWA on each side of the weak area. By example, the failed component 2 depicted in Figure 4 (side view) is a plates assembly built as in Figure 3 b), with EZ overlapping by 2 mm. Assuming that the vehicle in the example is tested for Protection Level 3 (see Annex B), the total width of the EZs is then 98 mm. With a length of 2 m on the occupant compartment, the vulnerable surface area of this defeated component is then 2 m x 0.098 m = 0.196 m².

For circular weak areas such as bolts or small holes, the default dimension considered as offering no protection is assumed to be a radius of E around the centre of the failed component, i.e. a diameter of 50 mm for Protection Levels 1 to 3. By example, the vulnerable surface area of component 3 depicted in Figure 4 (side view) includes a VA corresponding to $\pi \times (50 \text{ mm} / 2)^2 = 0.00196 \text{ m}^2$. The total VA of this component (four bolts) is then $4 \times 0.00196 \text{ m}^2 = 0.00785 \text{ m}^2$. For circular weak areas of radius larger than E, the edges are considered the discontinuities and the extent of the EZ is treated as in Figure 3 a), with a narrow MA at the centre of the weak area.

The default value of the EZ should be used unless evidences approved by National Authority (e.g. test data) demonstrate that a different value provides 90% probability of resistance to the hit.

In the example of the side view in Figure 4, the calculation provides a total threatened surface area A_0 of 12.85 m² and a total vulnerable surface area A_U of 0.86 m², for a RVA of 6.7% and an EPC of 93.3% for this view.

The acceptance criterion for the Phase 4 is an EPC of 90% for every view represented by the angles of attack specified in Annex A.

As a minimum, for vehicles with simple geometry, the EPC shall be determined for the front, sides, rear and highest elevation (e.g. roof at 30° for KE Protection Levels 1 to 3) attack angles. The analysis of RVA and EPC should be repeated at least for every 15° of azimuth and elevation as a minimum. For the Protection Levels 1 to 3, this represents 24 azimuth angles and 3 elevation angles (0°, 15° and 30°) for a total of 72 views. For Level 4, the total number of views is 24 (360° of azimuth and a fixed 0° elevation) and for Level 5, it is 5 views (-30°, -15°, 0°, 15° and 30° of azimuth and a fixed 0° elevation).

The computations associated with VA assessment could also be performed using vulnerability software that automatically calculates the RVA for every view defined in Annex A with angle of attack increments smaller than 15°.

On completion of the EPC computations for the entire vehicle protection system, an acceptance report shall be produced. It should indicate the computation methodology followed as well as the EPC calculated for every point of view analysed (without automatic software) or for the point of view showing the lowest EPC (with automatic software).

4. TEST EQUIPMENT

4.1 Test facility and arrangement

The test facility employed for the ballistic assessments should provide the conditions necessary to meet the requirements stated in the following Paras. The ballistic test arrangements should be similar to those shown in Figure 5. This document does not specify any details of the construction or management of the test facility.

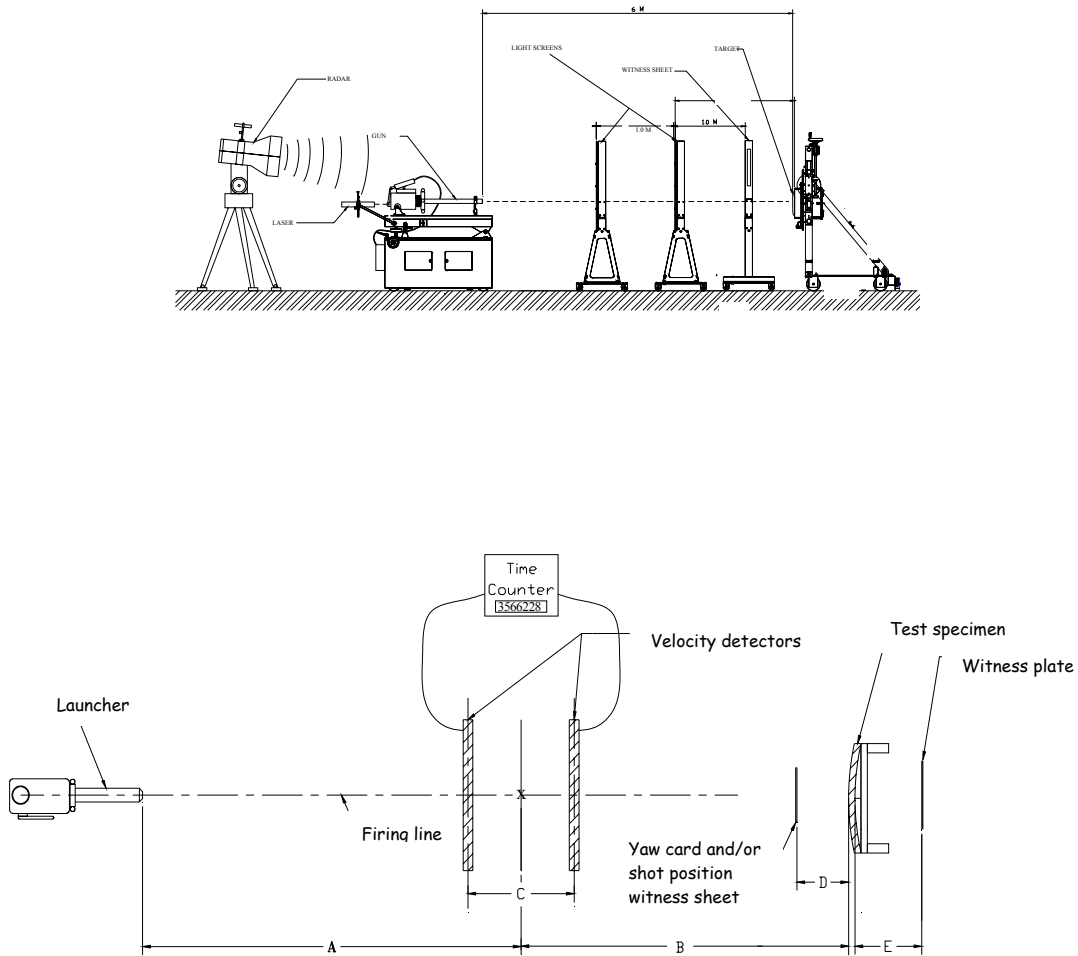

Figure 5 – Examples of experimental arrangement used for ballistic testing

4.2 Launcher to target distance

The launcher to target distance shall be selected such that there is a high probability of the impact conditions being FAIR in terms of velocity (Paras 4.5 and 5.6), yaw (Para 4.6) and impact position (Paras 5.4, 5.6 and Annex B).

4.3 Launching system

Any launching device may be used provided it is capable of consistently and reproducibly propelling the test projectiles (bullets or fragment simulators) at the required aiming point with an acceptable accuracy, impact velocity and angle of impact yaw.

4.4 Projectiles

The KE projectiles used in ballistic testing shall be of the type and calibre specified in Annex A. The FSP used to simulate the artillery threat should conform to the drawing and table provided in Figure 6 and Table 4. The 20 mm FSP is mandatory for Protection Levels 4 and 5 component acceptance tests.

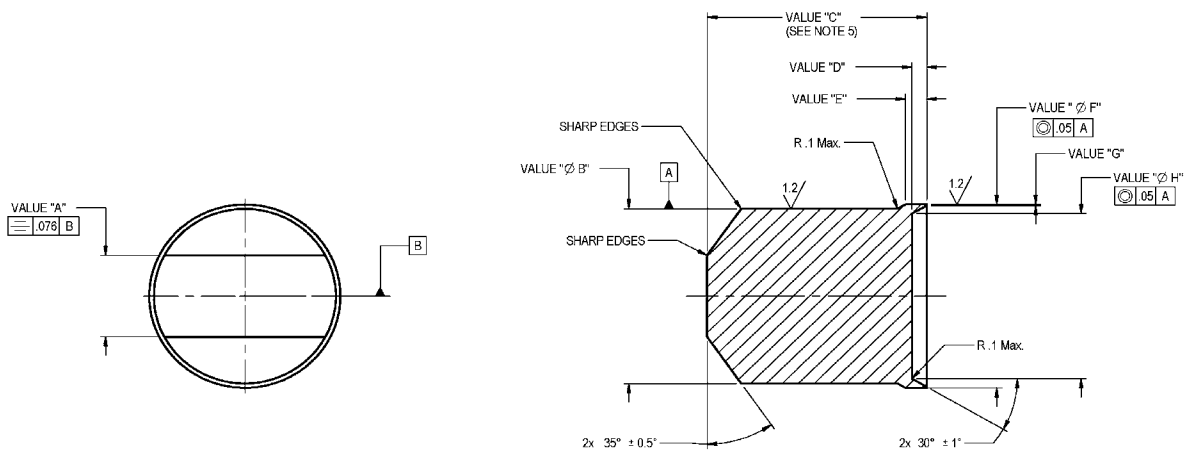

Figure 6 – Reference drawing for FSPs

AEP-55, Volume 1
(Edition 1)

Table 4 – Reference dimensions of FSPs

Fragment Simulator	Weight (g)	A (mm)	Ø B (mm)	C (mm)	D (mm)	E (mm)	Ø F (mm)	G (mm)	Ø H (mm)
12.7 mm	13.4±0.13	5.69-0.4	12.57±0.05	15.24	1.15±0.05	1.47±0.05	12.75+0.08	0.13 max	11.43±0.05
20 mm*	53.8±0.26	9.27-0.4	19.89±0.05	24.00	1.62±0.05	2.31±0.05	20.83+0.08	0.2 max	18.80±0.12

* Mandatory for Protection Levels 4 and 5.

4.5 Projectile velocity measurement

The velocity of each projectile shall be measured prior to impact with any suitable equipment (optical, magnetic, acoustic, X-ray, camera, break / make screens, Doppler radar, etc.) capable of providing an accuracy of ± 0.5%. The recommended measurement plane shall be located perpendicular to the projectile trajectory, at a maximum distance of 2.5 m ahead of the aim point on the target. If the striking velocity is measured at a distance greater than 2.5 m from the target, the striking velocity shall then be extrapolated from the point of measurement to the target using a recognised ballistic drag coefficient for the projectile in question. Supplementary details on velocity correction are given in Annex E.

4.6 Projectile yaw measurement and acceptance criteria

The yaw angle of the projectile at impact may be measured by any suitable method (e.g. yaw card, orthogonal photographic or flash X-ray system, Doppler radar system, etc.) that does not in itself cause projectile instability. A detailed procedure for computing the yaw angle from yaw card measurement is presented in Annex E.

The projectile yaw shall be within the limits specified in Table 5.

Table 5 - Impact yaw criteria

Threat projectile	Protection Level	Impact angle	Yaw criteria (Degrees)	Comment
KE bullets	1 - 3	All	<5	
	4 - 5	<60	<5	
		>60	<3	
		All	<3	Spaced targets
FSP	1 - 3	All	<5	Not mandatory
	4 - 5	All	<5	

The yaw shall be measured periodically during each test series. If excessive yaw is observed, all the firings conducted since the previous measured acceptable yaw will be considered invalid and shall then be repeated.

4.7 Impact location witness

In order to assess impact fairness, a shot location witness should be used to provide evidence of the exact impact point against the intended impact location of the projectile. A yaw card can act as a shot location witness (see Figure 5) even if the yaw measurement is achieved by another method.

4.8 Target types, retention method and orientation

Four target types can be used for ballistic evaluation.

1. Single plate targets: Such targets consist of a single armour material or combination of materials (composite armour).
2. Minimum engineered targets: These targets generally consist of various materials (metals, glass, ceramic, explosives, etc) either loosely assembled or lightly fastened together usually to aid handling during testing (taped, welded, bolted, glued, etc). Targets materials may be configured in contact or with air spaces.
3. Fully engineered targets: These targets are constructed to be fully representative of an actual vehicle armour system. This is achieved by using the same materials, hardware, construction techniques, fixing and mounting method etc, that would be used in the actual vehicle system application. These targets may include Paras of the real system (component mock-ups). Engineered targets may be mounted in a target stand or on a suitable vehicle.
4. Vehicle targets: These targets constitute the actual armour systems. They may be fully functional vehicles or ballistic test target structures (vehicle minus non-armour related components such as the power pack, gun system, etc.).

Single plate targets and minimum engineered targets can be used for R&D and quality control of materials and basics assemblies. Their size and rigidity will normally be reduced compared to fully engineered or vehicle armour target components. Single plate targets and minimum engineered targets represent only the materials that constitute armour panel MAs.

Component acceptance tests shall only use fully representative armour systems through the use of fully engineered or vehicle targets.

For single plate targets and engineered targets, a rigid support fixture shall be used so that the target remains firmly in place during and after the test event. The frame support and clamps or mounting fixture should be capable of retaining the target and withstanding shock resulting from ballistic impact by the test projectiles. The armour test target shall not be altered between the shots when the fixture needs to be re-tightened. The precise target boundary conditions used shall be described in such a way that each test is reproducible.

The support fixture shall be capable of ensuring impact point at the desired aim point and angle of obliquity within a tolerance defined in Para 5.6.

4.9 Witness system

For testing opaque and transparent armour material targets the witness system shall consist of a nominal 0.5 mm (± 0.05 mm) thick Aluminium alloy sheet (e.g. 2024 T3 or T4, AlCuMg ISO/R209 with min. tensile strength of 440 N/mm²). It shall be placed at a standoff distance of 150 mm (± 10 mm) behind and parallel to the back face surface of the target at the aim point as illustrated in Figure 5 (refer to distance E). The witness system should extend over a sufficient area (equal to or larger than the target size) such that all significant projectile or target debris can be detected.

If vision blocks are to be tested, a thinner witness (e.g. 0.05 mm aluminium foil) positioned at a shorter standoff distance (e.g. 50 mm) should be used. This arrangement better reproduces the typical distance from the vision blocks to the eyes and the lower eye injury tolerance (small width of the aperture requires a close approach by crew to effectively observe external features).

AEP-55, Volume 1
(Edition 1)

5. BALLISTIC TEST PROCEDURE FOR COMPONENT EVALUATION

A typical sequence for conducting ballistic tests on an armour component target consists of the following steps:

1. Launcher and ammunition preparation and conditioning
2. Range preparation and set up (e.g. chronographs, yaw cards etc).
3. Target preparation and conditioning.
4. Target installation and positioning.
5. Ballistic test firing and impact validity (FAIR / UNFAIR) evaluation.
6. Performance evaluation (partial or complete penetration).
7. Target component pass, fail or re-test assignment.
8. Test report generation and issue.

The following specific procedures and requirements are relevant to the process.

5.1 Test range ambient conditions

All testing procedures should be carried out in a test facility having the standard ambient conditions, i.e. a temperature of $20^{\circ} \pm 10^{\circ}\text{C}$. The temperature and humidity measurements can be made with any suitable equipment having a minimum accuracy of 1°C for temperature, and 3% for relative humidity (RH). The temperature and %RH of the test range should be recorded at the beginning and on completion of a test sequence.

5.2 Details and marking of targets

The test targets for all acceptance tests should only be either fully engineered or vehicle targets.

Prior to testing, each armour target should be visually or non-destructively examined to verify that no defect or other damage (dents, cracks, delaminations) exist and to identify potential LWAs. The critical dimensions and weight of individual component should be recorded. Based on these studies the required EZ and LWAs should be clearly identified and marked on all test targets.

All targets and any separate subcomponents including the witness plate should carry a unique identifying number that should relate to:

- The trial series number;
- The vehicle facet that the target represents;
- The threat weapon ammunition used in the assessment. Note that use of a threat code will allow easier / unclassified dissemination of results.

In addition, during testing all ballistic impacts should be individually marked on all components of the target and witness plate. Numbers should be sequential and account for all serials fired including any preliminary test rounds or non-FAIR impacts etc.

These unique target and ballistic impact numbers should be recorded within the test facility report.

5.3 Hit location and number

When a projectile (bullet or fragment simulator) strikes an armour panel, the material properties of the panel in a zone surrounding the point of impact are altered. The result of a subsequent round striking in this zone will be affected by these material changes. For the multi-hit test protocol, overlapping of shot damage zones is permitted. The separation distance allowed between shots and the shot pattern used are presented in Annex B.

In order to provide the required protection capability as defined in the STANAG for KE threats, the multi-hit testing protocol described in Annex B (see paragraphs 2, 3, 5 and 6) shall be used. Note that an optional, lower multi-hit protection capability for transparent armour is acceptable at the National Authority discretion (see Annex B Para 4), but vehicles classified under this protocol shall be classified as "STANAG 4569 KE Level X [PARTIAL]".

The armour target assessments for the following cases are all in single hit mode.

Armour target assessment in the single hit mode is specified for all ballistic impacts on EZ and all FSP threats. The single hit mode requires that every shot be completely independent and in original condition target material, i.e. with no interaction with target damage caused by other shots. Therefore, during testing, care must be taken to avoid any influence from previous impact damage that might deleteriously affect performance.

For MA testing all accepted impacts shall be at the specified distance away from the edges, seams and other discontinuities as presented (see Annex B). This distance is called the Excluded Zone (EZ).

The component area considered for the evaluation of SWAs is the EZ defined on MAs, i.e. 25 mm on each side for Protection Levels 1 to 3 and 50 mm for Protection Levels 4 and 5. To ensure that the shot is actually testing the SWA, the impact point shall be at a minimum distance from the aim point or the intended feature but not outside the EZ. Testing any LWAs present within a potential SWA shall be emphasized. With a welded joint for example, shots may be aimed at the centre of the seam, at the side of the seam and in any potential heat affected zone.

The shot locations selected should be such as to maximize the number of LWAs tested that also incorporate any prevailing geometric criteria i.e. those described in Annex B. With some materials (e.g. transparent armour), the weakest point of the panel will generally be at the perimeter of the component. In this case, the aim point should be chosen close to the border between the MA and the EZ reserved for SWA testing. For example, in the presence of a mosaic armour of tiles, the aim point should be at the tiles joint intersection.

In all cases, targets samples shall be of a size representative of the actual component on the vehicle protection system. If the size of the component is too small to be tested using the complete multi-hit shot pattern defined for the specified Protection Level, it shall be tested with only the two first shots of the patterns described in Annex B. If the component is too small to allow firing even only one pair of shots, it shall then be considered as a SWA and tested accordingly.

For Protection Levels 1 to 4, more than one four shot group may be fired at a target panel if it is judged by the National Authority that there is no interaction of the damage caused by the different shots groups.

5.4 Target conditioning

Prior to ballistic testing, each target should be pre-conditioned to a temperature of $20^{\circ} \pm 5^{\circ}\text{C}$ and a relative humidity (RH) specified by the National Authority for at least 12 hours. The targets should be reconditioned once their temperature is no longer within the tolerance band of $\pm 5^{\circ}\text{C}$. If different test conditions from these values are used, they should be clearly identified and recorded in the test report.

AEP-55, Volume 1
(Edition 1)

For test conditions where the temperature of the target is not the same as the test range conditions, the temperature of each target should be measured prior to and immediately following completion of the test and recorded in the test report.

The National Authority may specify pre-conditioning of targets that are sensitive to humidity. In those cases where the RH of the range test facility differs from that specified for the target, the test shall be performed within a maximum time of one hour following the completion of conditioning. This approach is appropriate to outdoor firing ranges where it is not possible to control the ambient test conditions.

The National Authority may require testing under extreme environmental conditions. In this case, the requirement should take into account the climatic zones defined in STANAG 2895. The precise requirements shall be defined in a specification or technical description.

5.5 Target positioning and obliquity measurement

Each target submitted for test shall be firmly mounted to a rigid support within the range facility. When mounting targets for testing to a holding rig or frame, care must be exercised to ensure that the loads applied or their method of application do not influence the ballistic response of the target.

The procedure used to position the target should ensure that the specified impact angle to the line of fire is achieved and measured at the intended point of aim on the target. The specified tolerance for the target obliquity is $\pm 0.50^\circ$.

The target obliquity should be measured for each round and recorded in the test report. Target obliquity is conventionally measured as the angle subtended between the normal (90°) to the plate surface and the line of fire. Other angular measurements may be taken provided a clear description or sketch defines the procedure used.

Single target angles can be used to represent compound angles provided their method of calculation is made explicit in the test report.

5.6 Test impact validity assessment

Once the conditions creating the expectation of a valid test are met, the actual firing sequence is performed with the appropriate measurement equipment. A ballistic impact is considered FAIR if it meets the criteria defined within this AEP as summarised below but is sentenced as UNFAIR if the criteria are not met. All ballistic impacts whether FAIR or UNFAIR shall be recorded in the test report.

- Impact velocity, tolerance ± 20 m/s from the nominal velocity (Annex A)
- Obliquity of impact, tolerance for the target obliquity $\pm 0.50^\circ$ (see Para 5.5)
- Yaw, tolerances 3° or 5° (see Para 4.6)
- Multi-hit testing criteria (shot positioning), see Annex B
- Distance from edge to impact point for MA testing (EZ):
 - 25 mm for Protection Levels 1 to 3.
 - 50 mm for Protection Levels 4 and 5 as well as for transparent armour Protection Level 1 to 3 PARTIAL (see Annex B).

(A shot impact location witness should be used to assess the edge separation distance, the distance from the intended point of aim and the distance between shots, when required (see Annex B)).

All FAIR impacts will contribute to the ballistic assessment of the target and must then be judged to meet (Partial Penetration, PP) or fail (Complete Penetration, CP) the specified performance requirement.

However, under certain conditions, impacts classified as UNFAIR may be accepted for the assessment. This situation arises if the UNFAIR impact creates more severe conditions yet performance requirements (PP) are met, or creates less severe conditions and results in a (CP).

The interpretation of what constitutes a FAIR and UNFAIR impact and whether ballistic tests are regarded as accepted or rejected depends upon the severity conditions defined in Table 6.

Table 6 - Individual impact fairness and severity conditions

Criteria	Fairness conditions	Relative severity	
		More severe conditions	Less severe conditions
Impact velocity	±20 m/s	Faster	Slower
Obliquity of impact	± 0.50° (see § 5.5)	Lower obliquity	Higher obliquity
Yaw angle	0 to 3° or 0 to 5° (see § 4.6)	Not applicable	Higher angle
Impact position (Phase 2 only)	In MA	In EZ	Not applicable
Impact separation distance	Single hit: see § 5.3	Shorter distance (damage zone overlapping)	Not applicable
	Multi-hit: see Annex B	Shorter distance	Longer distance
Impact group separation	See Annex B	Shorter distance (damage zone overlapping)	Not applicable

If the test conditions of an UNFAIR impact are less severe than specified and the performance requirements are not met (CP), this will be considered as an accepted impact, and will constitute a target failure. If the performance requirements are met (PP) the UNFAIR impact is considered as rejected.

Another situation may arise in multi-hit evaluation when an UNFAIR impact is accepted because it led to a target success (PP) under more severe conditions. However, any subsequent impact on the same target is considered UNFAIR by default even though the firing conditions of the impact were within the given tolerances. Nevertheless, the impact shall be accepted if it leads to success (PP) but rejected if it leads to failure (CP). In this last case, all the previously accepted impacts are also rejected and shall be repeated.

If a certain number of impacts of a four-shots pattern are performed and are accepted PP and then a subsequent impact is a rejected CP (more severe UNFAIR impact), all the previous impacts are to be rejected and shall all be repeated.

AEP-55, Volume 1
(Edition 1)

5.7 Witness plate and armour examination

The level of damage on the aluminium witness plate is the performance criterion for the evaluation of success or failure of a target against a particular projectile. Nevertheless, armour target damage examination is also required since it contributes to the decision on continuing or halting the test sequence for a component (see Table 3).

After each ballistic impact, the witness plate shall be visually examined for damage and evidence of penetration by the projectile or target materials. A CP is recorded when light is observed to pass through the damage in the witness plate. A PP is recorded when no light is visible through the damage if present.

All observable damage on the witness plate should be appropriately marked and numbered to allow traceability. The witness plate should be moved or replaced during the assessment to ensure that observable damage areas from individual test impacts remain discrete from one another.

5.8 Component performance determination

Following completion of the ballistic test sequence with the number of shots required by each Phase of the assessment (see Table 3), the success or failure of a component is determined. Component design failure is defined when one or more accepted impact results in CP of the target.

Following the failure of a component design the National Authority may select one of the following three options.

Option 1. A single re-test of the failed component design with the identical configuration is allowed. The re-test should comprise the full number of rounds stated within Table 3 with no reduction allowed.

Option 2. A full re-test using revised armour solutions (effectively a resubmission).

Option 3. The component is considered as comprising a VA for the purposes of the Protected Area calculation.

The process of testing and acceptance is summarized as a flow chart in Annex F.

An example is provided for a Level 1 target assessment, indicating the possibilities available to the National Authority during the test process.

If shot #10 is achieved with no CP of the target, the National Authority may decide that the test can be stopped if target damage is sufficiently low and the component is then accepted as successful. Again, if testing continues to shot #22 without CP, the component is also accepted as successful.

If a CP occurs between shots #11 to #22, the test could be stopped since this AEP allows no CP within the series. At National Authority discretion the series could be continued to shot #22, but this is not required by the AEP. However, if a second CP does occur up to #22, the component is declared failed and re-test of the same target recipe is not allowed.

If a CP occurs before shot #10, the test could be stopped, but the National Authority could still ask to complete the series to shot #22. If no other CP occurs, the National Authority could choose between declaring the component failed, allowing a re-test of the same recipe or asking for a resubmission. If an additional CP occurs within the remainder of the 22 shot series, a re-test of the same target recipe is not allowed.

5.9 Ballistic test report

In order to proceed with the VA assessment, the following information for every target component ballistically tested shall be fully documented in a report.

- a. Date and place of trial, Protection Levels tested.
- b. Actual firing range used, distance from velocity measurement point to target, witness plate material, thickness and standoff distance.
- c. Photo or drawing of test set-up identifying components and defining positions / distances.
- d. Name of the testing personnel.
- e. Target type (fully engineered or vehicle) and aim zone (MA with or without LWA in Phase 2 or SWA with or without LWA in Phase 3).
- f. Temperature and relative humidity at the test facility, and target pre-conditioned temperature if different from test facility.
- g. For each shot, projectile nomenclature and description, along with any information on manufacture and provenance.
- h. For each test series, barrel calibre, length, and twist if applicable, test specimen-mounting configuration.
- i. For each shot, approximate location of impact, intended and actual striking velocities obtained, angle of yaw, partial or complete penetration, FAIR or UNFAIR impact, accepted or rejected impact and notes on target damage, e.g. bulge and cracks.
- j. For each test series, indication of compliance with minimum specified ballistic performance requirements.
- k. When appropriate, justification of reduction of the number of test rounds according to Table 3.
- l. Any other information or remarks pertinent to the conduct of the test, or behaviour of the material to demonstrate that the requirements of this AEP have been met.
- m. Type, mass and dimensions of the projectile, calibre, core diameter, lot number, model number, name of supplier, country of manufacture, and ballistic retardation if known.

Any other information relevant to the National Authority, particular requirements or conditions of the target and threat should be documented, such as:

- a. The level of classification (unclassified, confidential...) of the test results.
- b. Sampling procedure, and full description of each armour target tested including: mass, size, areal density, thickness (max., min., mean), hardness (max., min.) nominal areal density, material type, manufacturer and lot number.
- c. Photograph of targets before and after testing, penetration depth etc.
- d. A table or graph of propellant charges versus muzzle velocity.

Test conditions and projectiles

Table A1 – Test conditions and projectiles summary for KE and artillery threat

Level	KE threat				Artillery threat (FSP 20 mm)		
	Ammunitions	V _{proof} * (m/s)	Azimuth	Elev.	V _{proof} (m/s)	Azimuth	Elev.
5	25 mm x 137 APDS-T, PMB 073	1258	±30°	0°	960	0 – 360°	0° – 90°
4	14,5 mm x 114 API/B32	911	0 – 360°	0°	960	0 – 360°	0° – 90°
3	7,62 mm x 51 AP (WC core)	930	0 – 360°	0° – 30°	--	0 – 360°	0° – 30°
	7,62 mm x 54R B32 API	854					
2	7,62 mm x 39 API BZ	695	0 – 360°	0° – 30°	--	0 – 360°	0° – 22°
1	7,62 mm x 51 NATO ball	833	0 – 360°	0° – 30°	--	0 – 360°	0° – 18°
	5,56 mm x 45 NATO SS109	900					
	5,56 mm x 45 M193	937					

*V_{proof} = Figures are mean values: tolerance of striking velocity for individual shot is ± 20 m/s

Table A2 - Accepted test projectiles and characteristics

Level	Ammunitions	Name	Material	Projectile weight(g)	Comment
5	25 mm x 137 APDS-T, PMB 073	Oerlikon-Contraves	W alloy core	121.5 (150 with sabot)	Unique supplier
4	14,5 mm x 114 API/B32	Russian 14,5 mm API/B32	Steel core	64	Original ammunition design
		Barnaul AP-I 57-BZ-561S	Steel core	64	Specific manufacturer
		Chinese 14.5 mm Type 56	Steel core	64	Chinese designation
		ARL Drawing number 32000	Steel core	63.4	Surrogate without incendiary. Figure A1.
3	7,62 mm x 51 AP (WC core)	Nammo AP8	W alloy core	8.4	Present day available product
		Bofors Carl Gustav FFV AP M993	W alloy core	8.4	Designation under previous supplier
			W alloy core	8.4	US designation of the same round
	7,62 mm x 54R B32 API	Russian 7,62 x 54R B32 API	Steel core	10.04	Original ammunition design
	Chinese 7,62 x 54R B32 API	Steel core	10.04	Chinese equivalent	
2	7,62 mm x 39 API BZ	Russian 7,62 x 39 API BZ	Steel core	7.77	Original ammunition design
		Chinese 7.62 x 39 Type 56	Steel core	7.67	Chinese designation
1	7,62 mm x 51 NATO ball	Ball M80	Lead core, copper jacket	9.65	US designation for the 7.62 x 51 NATO ball
		C21	Lead core, copper jacket	9.5	Canadian designation for the 7.62 x 51 NATO ball
		DM41	Lead core, copper jacket	9.45	German designation for the 7.62 x 51 NATO ball
	5,56 mm x 45 NATO SS109	SS109	Steel and lead core, copper jacket	4	Original ammunition design
		M855	Steel and lead core, copper jacket	4	US designation for the 5.56 x 45 NATO SS109
		DM11	Steel and lead core, copper jacket	4	German designation for the 5.56 x 45 NATO SS109
	5,56 mm x 45 M193	M193	Lead core, copper jacket	3.56	Original ammunition design

ANNEX B
AEP-55, Volume 1
(Edition 1)

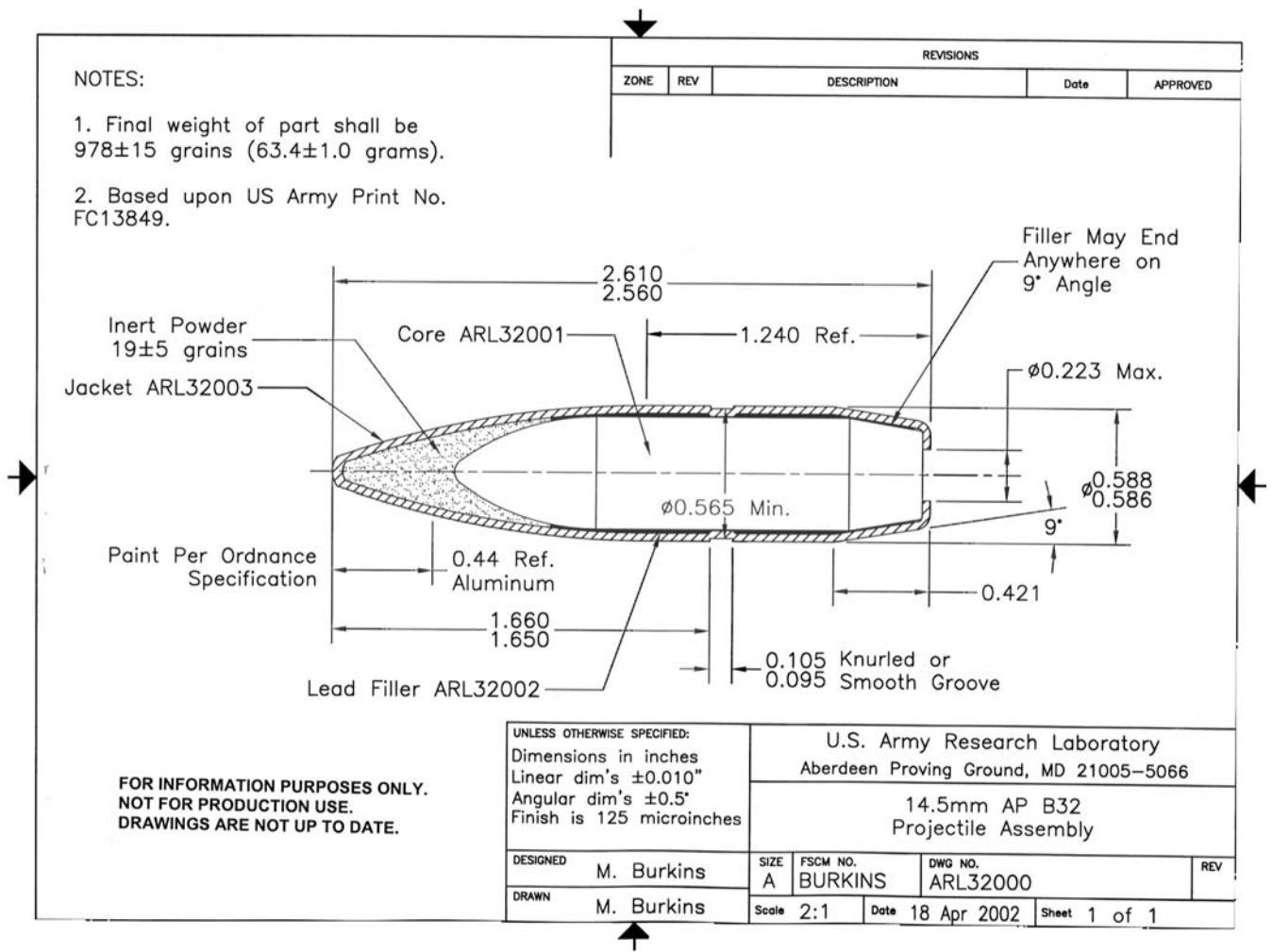

Figure A1 - Drawing of Protection Level 4 threat (ARL Drawing 32000)

MULTIPLE HIT TESTING

1. General

The capability of the armour system under evaluation to with stand multiple impacts (multi-hit requirement) from the specified test projectiles is included as part of the Phase 2 V_{proof} ballistic assessment process.

The application of multi-hit conditions to armour component ballistic testing require a number of geometric parameters be defined in order to obtain a reproducible and fair evaluation. These parameters and qualifying comments are as follows:

1. **Distance between the centres of individual shot impacts.**
The specified shot patterns / separation distances have been determined from the results analysis of realistic live fire test scenarios or ballistic trials experience. Alternative patterns are allowed for transparent armour as described below.
2. **The impact accuracy tolerance.** The values for individual rounds are based on National Authority technical expert experience of the weapons and projectiles concerned. National Authorities may at their discretion demand tighter impact accuracy tolerances than those stated herein.
3. **The EZ.** The minimum specified distance that the ballistic assessment impacts shall be separated from component panel edges, to avoid testing within a SWA.
4. **Component target size effects.** To address cases where the target size is small compared to the test multi-hit test pattern area, a shot pattern with reduced number of shots is allowed.

This Annex specifies the multi-hit assessment requirements for opaque and transparent armour components for Protection Levels 1 to 5.

In addition, alternative multi-hit assessment requirements are provided for transparent armour in Protection Levels 1 to 3. Evaluations carried out under these test conditions will be accorded a [PARTIAL] nomenclature.

It is a requirement for multi-hit testing that all ballistic impacts shall attempt to exploit the Localized Weak Areas (LWA) of the armour target where present or suspected.

2. Multi-hit requirements for Protection Levels 1 - 3

For Protection Levels 1 to 3, the multi-hit procedure is based on an ambush scenario where an individual with personal weapon attacks an immobile vehicle for the equivalent of 4.5 seconds per occupant. The derived multi-hit pattern is two pairs of impacts repeated at a prescribed distance.

The multi-hit parameters that shall be respected for ballistic assessments conducted with the projectiles specified for Protection Levels 1, 2 and 3* are defined in Table B1, and illustrated in Figure B1.

Table B1 – Shot separation and impact tolerances for Protection Levels 1, 2 and 3

Dimension definition	Value	Size (mm)
Distance between shots pairs (#1 & #2, #3 & #4)	N	25
Distance from midpoint of shots #1 and #2 to shot #3	L	100
Maximum tolerance on shot impact position	T	-0 / +20
EZ (Minimum distance to component target edge / boundary)	E	25

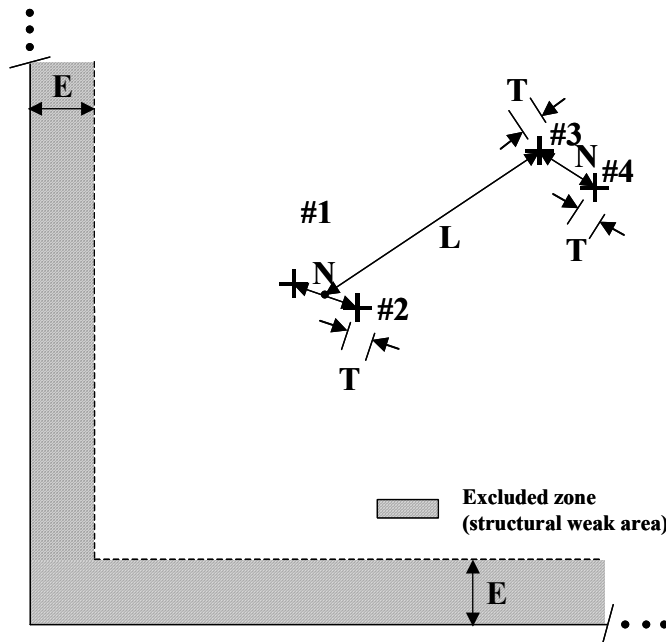

Figure B1 – Example of multi-hit shot pattern for Protection Levels 1 – 4

Any vehicle successfully assessed using the requirements specified above shall be classified as compliant with “STANAG 4569 KE Level X”.

3. Multi-hit procedure for Protection Levels 1 - 3

The detailed procedure for multi-hit assessment is described below with reference to the drawings (a - h) within Figure B2.

Shot #1: The first projectile (#1) is fired at the chosen aim position, which should be LWA if present (Figure B2 a); the actual impact should be within a ± 10 mm zone of this point.

Shot #2: The possible positions for the second shot (#2) are then determined by tracing concentric circles of minimum radial distance N and maximum radial distance N+T onto the target (Figure B2 b). Once shot #2 is completed of the defined zone (Figure B2 c), the allowed area for the third shot (#3) can be defined.

Shot #3: Two concentric circles centred on the midpoint between shots #1 and #2, of minimum radial distance L and maximum radial distance L+T can be traced on the target. From the midpoint, an angle of $\pm 60^\circ$ is traced in the directions perpendicular to shot #1 and to shot #2. The zone formed by the concentric circles and the angles is the allowed area for shot #3 (Figure B2 d). (Figure B2 e).

Shot #4: The fourth shot shall be aimed in the zone formed by concentric circles at distances of N and N+T from the impact point #3, but not closer to the midpoint of shots #1 and #2 than the distance L, as illustrated in Figure B2 f.

On completion of shot #4 (Figure B2 g), the resultant four shot pattern is as illustrated in Figure B2 h.

ANNEX B
 AEP-55, Volume 1
 (Edition 1)

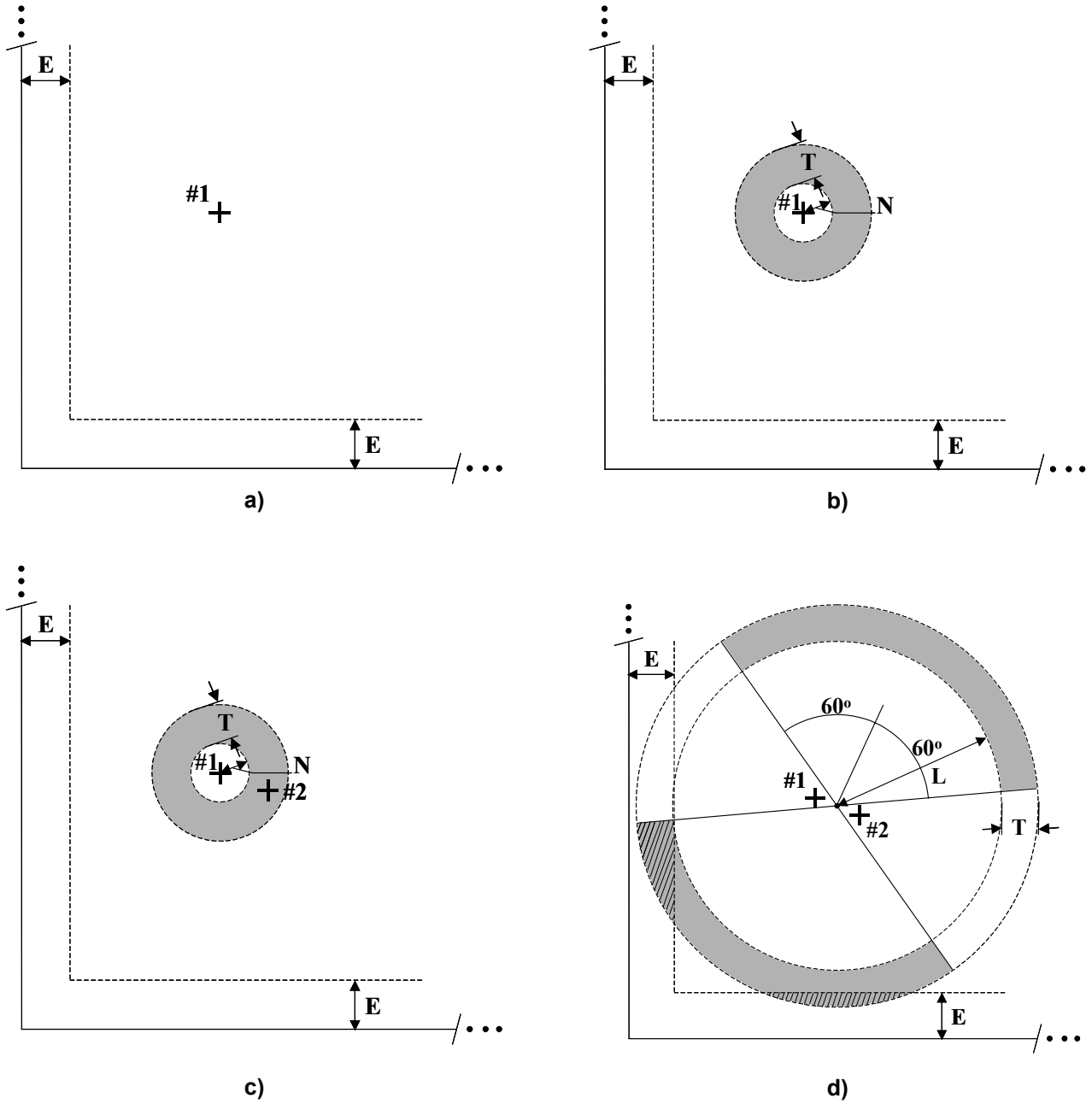

Figure B2 – Multi-hit sequence for Protection Levels 1-4

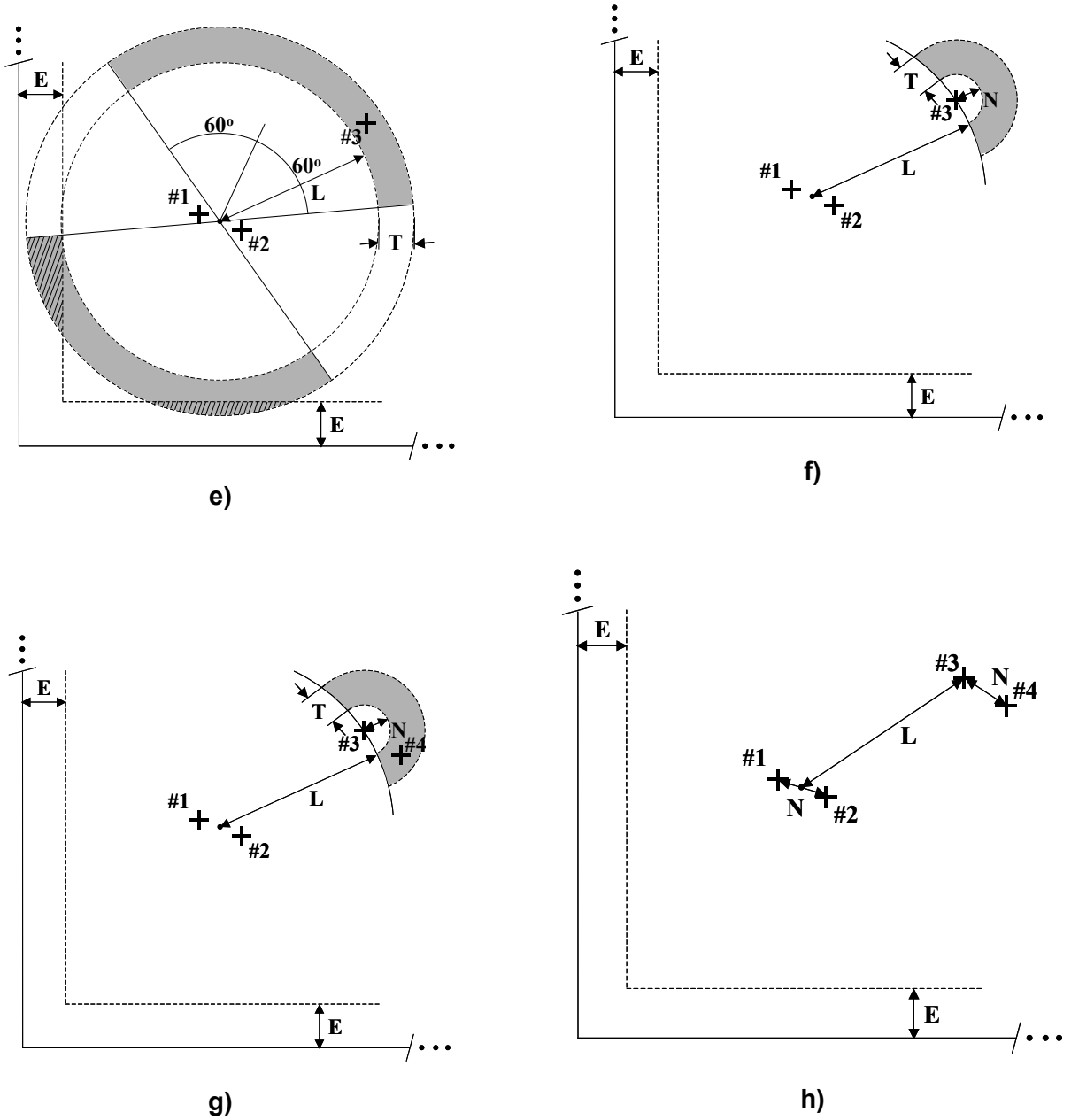

Figure B2 – Multi-hit sequence for Protection Levels 1-4 (continued)

4. Alternative multi-hit procedure for Protection Levels 1 - 3 (Transparent armour only)

Achieving the specified Level 1 - 3 multi-hit ballistic resistance requirements for transparent may be impractical due to weight, geometric or human factor constraints.

Accordingly, if a lower multi-hit ballistic resistance is acceptable to National Authorities, the following alternative testing protocol may be used for transparent armour only. Any vehicle successfully assessed using the alternative requirements specified shall be classified as compliant with “STANAG 4569 KE Level X [PARTIAL]”.

The alternative multi-hit test protocol for transparent armour requires three impacts in an equilateral triangle with a separation of 120 mm between impacts. The tolerance distances is -0 + 20 mm. The distance from the edge (E) shall be at least 50 mm. The pattern is illustrated in Figure B3.

Table B2 – Alternative shot separation tolerances for transparent armour (Protection Levels 1, 2 and 3)

Dimension definition	Value	Size (mm)
Distance between shots (equilateral triangle)	N	120
Tolerance on shot impact	T	-0 / +20
Minimum distance to component target edge / boundary	E	50

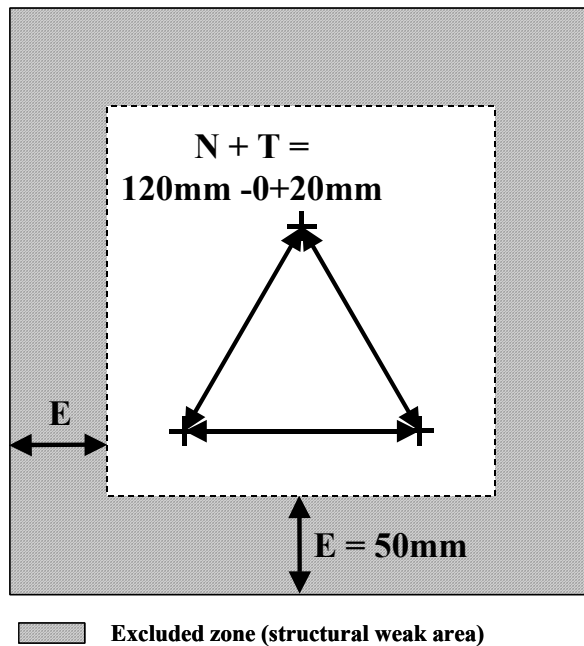

Figure B3 – Multi-hit pattern for Protection Levels 1 - 3 PARTIAL (transparent armour).

5. Multi-hit procedure for Protection Level 4

For Protection Level 4, the multi-hit procedure is based on an ambush scenario where a fixed heavy machine gun attacks an immobile vehicle with a five rounds burst. The derived multi-hit pattern is two pairs of impacts repeated at a prescribed distance as described for Protection Levels 1 to 3.

The assessment procedure is the same as for Protection Levels 1 to 3 as illustrated in Figure B1 and B2, but with the shot spacing and impact tolerance parameters as presented in Table B3.

Table B3 – Shot distance and tolerances for Protection Level 4

Dimension definition	Value	Size (mm)
Distance between shots of pairs	N	50
Distance from centre of shots #1 and #2 to shot #3	L	200
Maximum tolerance on shot impact position	T	-0 / + 50
Minimum distance to component target edge / boundary	E	50

6. Multi-hit procedure for Protection Level 5

For the Protection Level 5, the multi-hit procedure is based on a unique two shot pattern per target sample as illustrated in Figure B4 and the shot spacing and impact tolerance parameters as presented in Table B4.

Table B4 – Shot distance and tolerances for Protection Level 5

Dimension definition	Value	Size (mm)
Distance between shots of a pair	N	150
Maximum tolerance on shot impact position	T	-0 / + 50
Minimum distance to component target edge / boundary	E	50

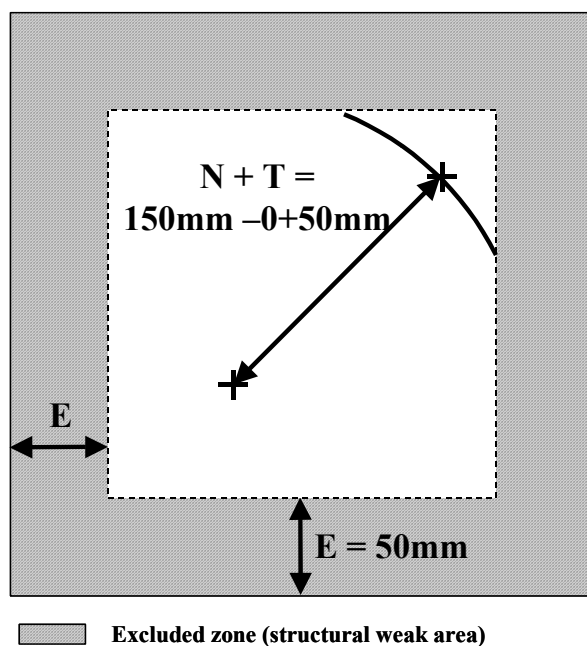

Figure B4 – Multi-hit pattern for Protection Level 5

7. Multi-hit tests – target numbers and size

Sufficient MA targets should be made available to perform the V_{proof} multi-hit ballistic assessments required for each Protection Level.

The number of targets required will be dependent on several factors:

- The number of accepted shots required for the assessment as described in Table 3.
- The multi-hit shot pattern demanded as described in Tables B1 - B4 above.
- The actual size of the target component.
- Allowance for contingency.

For Level 1 - 4 multi-hit assessments, testing shall be performed with the four-shot patterns described. However, where the total number of rounds is not a multiple of four, testing may conclude with a pair of shots to finish a series, and these can be on a separate target. For example, after shooting five panels of four shots (twenty shots), the last two shots required by Table 3 to reach the twenty-two shot total could be fired in a single pair without completing another four-shot pattern.

The influence of the size of the component on the multi-hit test procedure is described in Para 5.3.

ARTILLERY THREAT

1., The details of the artillery threat and protection requirements in terms of the HE shell type, Protection Level, protection ranges and attack elevations were included in STANAG 4569 for reference purposes mainly, to provide advisory information for military commanders on vehicle spacing during operations.

2. The performance data presented is empirically based upon 155 mm shells attacking Rolled Steel armour plate assessed in arena trials and encompasses the two following important points:

- The attack elevation quoted for Levels 1 through 3 in the STANAG 4569 Annex A were derived assuming shell detonation occurred at heights up to 30 m above ground level. For Levels 4 and 5 in the STANAG 4569 Annex A, the attack angle is all around and over the vehicle at a distance of 25 m.
- Protection Levels take into account a 90% chance of surviving a single shell detonation only. (It should be noted that if protection against multiple shell detonations is desired then the probability of occurrence of a closer range detonation and of being struck by a larger fragment both increase).

3. At the long ranges of artillery engagement appropriate to Protection Levels 1 - 3, the low obliquity of attack achievable on a vehicle roof coupled with low fragment impact velocity on account of their high drag coefficients leads to the KE projectile threats dominating the armour demand. The chance of impact from a large fragment from a single shell detonation at ranges of 60 - 100 m is also extremely low. Hence, no testing against Level 1 - 3 fragment threats is required by STANAG 4569, but is optional to the National Authority.

4. However, for Protection Level 4 and 5 different circumstances apply, as the detonation range is close enough to allow high velocity fragment attack at 90° to the vehicle roof. As the KE threats for Level 4 - 5 are disposed horizontally the artillery threat determines the roof protection requirement, and thus fragment testing of vehicle armour is required to fully comply with STANAG 4569. It is mandatory to test at a 30° attack angle. Testing between attack angles of 30° and 90° is optional to the National Authority.

5. The assessment of protection provided from artillery shell fragment threats is to be achieved using gun launched fragment simulating projectiles (FSP) as defined in Figure 6 of calibre 20 mm and at velocities in accordance with the Table C1 below. The data included for Levels 4 - 5 is summarised from Table A1 of Annex A.

Table C1 – FSP Velocities for testing for Protection Levels 4 and 5 (Levels 1, 2 and 3 for information only)

Protection Level	Range of burst (m)	20 mm FSP V_{proof} (m/s)
5	25	960
4	25	960
3	60	(770)
2	80	(630)
1	100	(520)

6. A reduced amount of single impact FSP testing compared with the KE threats is demanded as indicated in Table 3. No multi-hit testing is required reflecting the wide dispersion of shell fragments in real situations even at 25 m range of detonation. Testing is however required to assess both the Main and Weak armour Areas (LWA and SWA).

SHATTER GAP TESTING

1. Shatter-gap is a phenomena exhibited by a few projectile / armour material interactions. The classical shatter-gap is exhibited when the projectile core is shattered and thereby defeated by the armour when impacted at relatively high velocities (see Refs. 18, 21 and 22). At lower velocities, the projectile could however defeat the armour because the impact energy is insufficient to break the projectile core. This usually results in projectile / armour combinations having multiple ballistic limit values as shown in Figure D1. The classical shatter gap phenomenon is most common with ceramic armour systems. Where a shatter gap is suspected, an appropriate test procedure should be employed to explore the possibility of low velocity penetration.

2. Comprehensive testing to explore the possibility of shatter gap vulnerability requires a large number of tests at various reduced velocities. Such investigations are at the discretion of the National Authority and do not fall within the test requirements of this AEP. Nonetheless armours that are found to have vulnerability to the threat projectile listed in this AEP but at lower velocities than is specified in this AEP are considered to fail to meet the requirement.

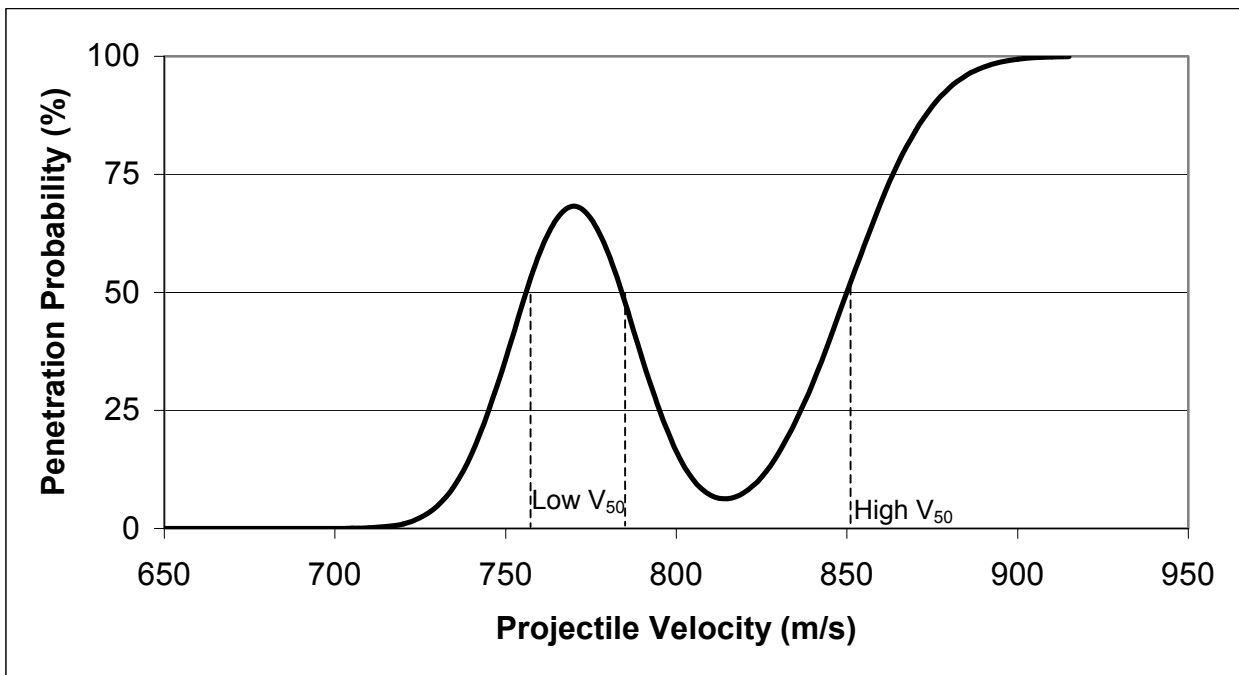

Figure D1 - Example of shatter gap penetration probability distribution with multiple V_{50} .

TEST EQUIPMENT ISSUES**1. Velocity correction**

No corrections for air drag effect are required for KE projectiles when the striking velocity is measured at a distance of 2.5 m or less from the target (distance **B** in Figure 5). When projectile velocity is measured at a distance greater than 2.5 m from the target, the striking velocity V_s shall then be calculated from the point of measurement to the target. The drag coefficients listed in Table E1 could be used with the formula provided below, but measured values for the projectiles used are preferable.

Table E1 – Drag coefficients for KE threats

Protection Level	Drag coefficient
1 - 4	0.33
5	0.165
20 mm FSP	1.500

A common method used for velocity correction is the exponential decay law based on a constant drag coefficient C_d , and can be calculated using the following formula:

$$V_s = V_i \cdot \exp\left(\frac{-X\rho C_d \pi D^2}{8m}\right)$$

where X is the distance from the measurement point to the target, ρ is the air density (1.225 kg/m^3 at sea level and standard conditions), D is the projectile calibre (excluding sabot), m is the projectile mass, and C_d is the average drag coefficient for the effective velocity range.

An alternative velocity correction method for air drag is by direct measurement of velocity at multiple distances and extrapolation to the target strike face.

2. Yaw angle characterization

The measurement of projectile impact yaw angle is an important feature of ballistic testing as the yaw value, or even rate of yaw, may determine the ultimate target response and may influence whether a PP or CP results for a given threat / target geometry.

For the ballistic assessments with KE bullets and FSPs described within this AEP, it is necessary to routinely measure indicated projectile yaw for each firing and also to determine precise yaw within a test series as described below.

The use of a yaw “card” is a simple and effective method of assessing projectile yaw. The card material utilised should be suitable in that on perforation a clean hole or signature is produced faithfully recording the presented area of the projectile, but critically without in any way disturbing the onward flight characteristics of the projectile.

ANNEX E
 AEP-55, Volume 1
 (Edition 1)

Cards should be placed in a series perpendicular to the line of flight with the last card positioned as close to the target surface as practicable (within 150 mm from the target is desirable - closer distances may result in fragmentation damage). The perforation hole is measured only if a visible observation of the projectile profile signature indicates that yaw is present. When a series of yaw cards (e.g. 7) are positioned at regular measured distances between the weapon and the target, the yaw cycle can be extrapolated to determine precisely the projectile yaw at impact with the target.

When using FSPs, the dimensions $D1$, $D2$ and L (see Figure E2) should be measured and recorded. Yaw is then computed by measuring, using an optical device with a magnification factor of at least 5X, the largest dimension (A) of the hole caused during perforation of the yaw card. For fragment simulator having no rear skirt, $D1=D2$. The yaw angle (θ) is then determined for cylindrical projectiles using the following formulas:

$$DM = \frac{D1 + D2}{2}$$

$$T = \sqrt{L^2 + DM^2}$$

$$\theta = \alpha - \beta = \sin^{-1}(A / T) - \tan^{-1}(DM / L)$$

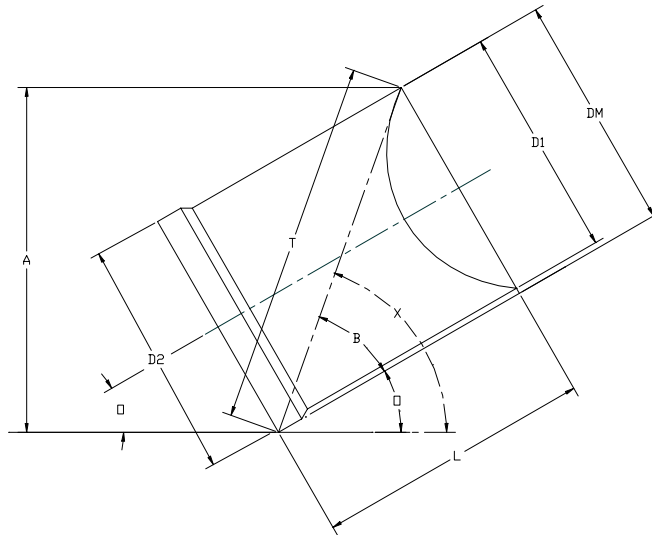

Figure E2 - Reference dimensions for yaw measurement with FSP

When the hole in the yaw card is a perfect circle no yaw is present in the projectile at the point of measurement.

Photography or flash radiography are alternative methods used for precise yaw measurement. Measurement is required at least once per test series. When using photography or flash radiography, two orthogonal measurement planes shall be used to allow visualisation of yaw in both the horizontal "X" and vertical "Y" directions combined (*Av* and *Ah*). With photographic systems, the use of a 45 degrees inclined mirror allows capture of two orthogonal images (actual side view and reflected top view) on a single image. The mirror and camera jig system should be aligned to the flight of the bullet with an in-bore laser using two pin hole screens to ensure proper alignment with the launcher axis. The images taken should also include a zero degree reference line from which each yaw component will be measured. The total compound yaw (Θ) angle can then be computed by applying the following formula:

$$\Theta = \arctan \sqrt{\tan^2 Av + \tan^2 Ah}$$

FLOW CHART SUMMARY OF THE TESTING AND ACCEPTANCE PROCESS

The sequence of the acceptance test of a component are illustrated in the flow chart presented in Figure F1, referring to the following note and decision points:

Decision I: A decision by the National Authority is required:

- A. To stop the component testing after reaching the allowed minimum number of accepted shots (Table 3, numbers in parenthesis) when the back surface damage is judged by the National Authority to give full confidence that further testing will not lead to an accepted CP, or;
- B. To continue the component testing.

Decision II: Following the occurrence of a single CP in the test series, the National Authority may decide to:

- A. Declare the component design as failed.
- B. Continue testing the component as long as desired, until the maximum number of accepted shots required, as shown in Table 3, is reached, in anticipation of performing a retest. (Note that only one retest of a given component design is permitted, and if an additional accepted complete penetration occurs in either the remainder of the first test or the retest the component is declared vulnerable.)

Decision III: The National Authority may decide to:

- A. Accept to declare the component as failed and representing VA.
- B. Accept to test another component of revised component design if proposed by the manufacturer (re-submission).

Decision IV: Following the occurrence of a single accepted CP, when the maximum number of accepted shots has been reached without subsequent accepted CP, The National Authority may decide to:

- A. Accept to retest the same component design.
- B. Accept to declare the component design as failed.

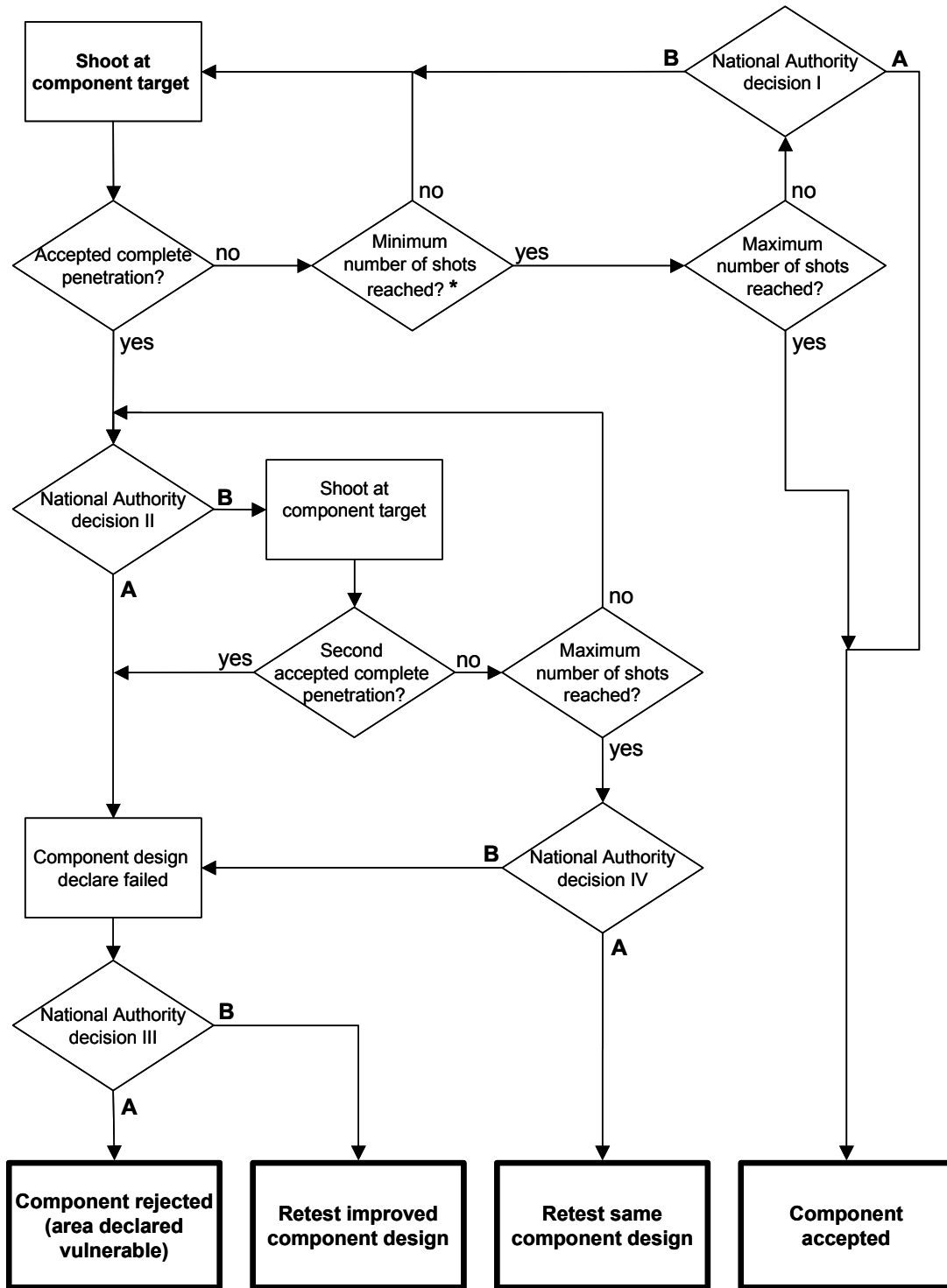

Figure F1 – Ballistic testing algorithm

* The minimum number of accepted shots required is shown in parenthesis in Table 3.

OPTIONS FOR BALLISTIC PERFORMANCE EVALUATION

1. The V_{proof} and V_{50} tests are only two of several types of test to determine the ballistic performance or failure characteristics of armour materials against KE projectile. Other types of tests that may be relevant include:

- a. Behind-armour debris test (i.e., fragmentation) arising from penetration of the armour by a KE projectile, or from damage such as back spall produced by a non-perforating projectile.
- b. Critical angle tests where the striking velocity is kept constant throughout a test series but target obliquity is progressively changed to determine the angle at which the KE projectile will be stopped with a given probability level and confidence limit.
- c. Critical velocity (V_c) tests based on projectile residual velocity or residual momentum measurements (ballistic pendulum) to determine the armour energy absorbing capability when penetrated (overmatched).
- d. Depth of penetration (DOP) test where a homogeneous semi-infinite backing is placed behind a tested component or material target and scoop depth measured.

2. The tests 1 - 4 may not be used in place of the ballistic tests prescribed in this document but can be carried out in addition to provide supplementary information.

DEFINITIONS

For the purposes of the test methods and procedures contained herein, the following definitions apply:

Add-on armour (additional or appliqué armour): An armour system that can be easily installed or removed from a vehicle without adversely affecting its structural integrity or operation. It usually covers the identified vulnerable areas and provides.

Angle of azimuth: The angle in the horizontal plane between the vehicle longitudinal axis and the line connecting the firing point and the rear of the vehicle occupant compartment (see Figure 1).

Angle of elevation: The angle between the plane of the horizon and a line drawn from the firing point to the point of impact on the target surface (see Figure 1).

Angle of impact: The angle between the projectile trajectory and the direction perpendicular to the plane tangent to the point of impact on the target sample (see Figure H1 next page). The angle of incidence and target obliquity may be used with the same meaning. Angle of impact should not be confused with yaw angle nor the angle of azimuth or elevation.

Area of coverage: The area of an armour target that meets or exceeds the ballistic Protection Level requirement to achieve a specified Protection Level.

Areal density (AD): The weight of armour material per unit area. It is usually expressed in kg/m^2 and is the ratio of the mass of the armour material over its area of coverage.

Armour: A shielding material provided for protection against ballistic threats.

Ballistic resistance: The measure of the potential of a protection system component to defeat an impacting projectile or fragment.

Ballistic retardation: The velocity reduction of a projectile caused by air drag, per unit distance (m/s/m).

Bulge height: The maximum permanent displacement of the back surface of an armour test target caused by projectile impact on the front surface.

Cavity diameter or size: The diameter of the hole made in the armour material measured from the undistorted front and back surface. For a non-symmetric cavity, both the smallest diameter (width) and the largest diameter (length) should be measured and recorded.

Complete penetration (CP): A complete penetration has occurred when an impacting projectile cause the projectile, a piece of the projectile or target debris to pass through the witness plate, i.e., there is at least one perforation through which light is visible through the witness plate.

Component: A discrete part of a vehicle protection system that requires ballistic protection assessment. For the purpose of this assessment, two kinds of components are used, those representing Main Area and those representing Structural Weak Areas (Excluded Zone). The definition of component as used in this document is not that commonly used in Vulnerability Analysis, which includes non-protective parts of the vehicle to evaluate the full vulnerability of a vehicle (e.g. mobility kill).

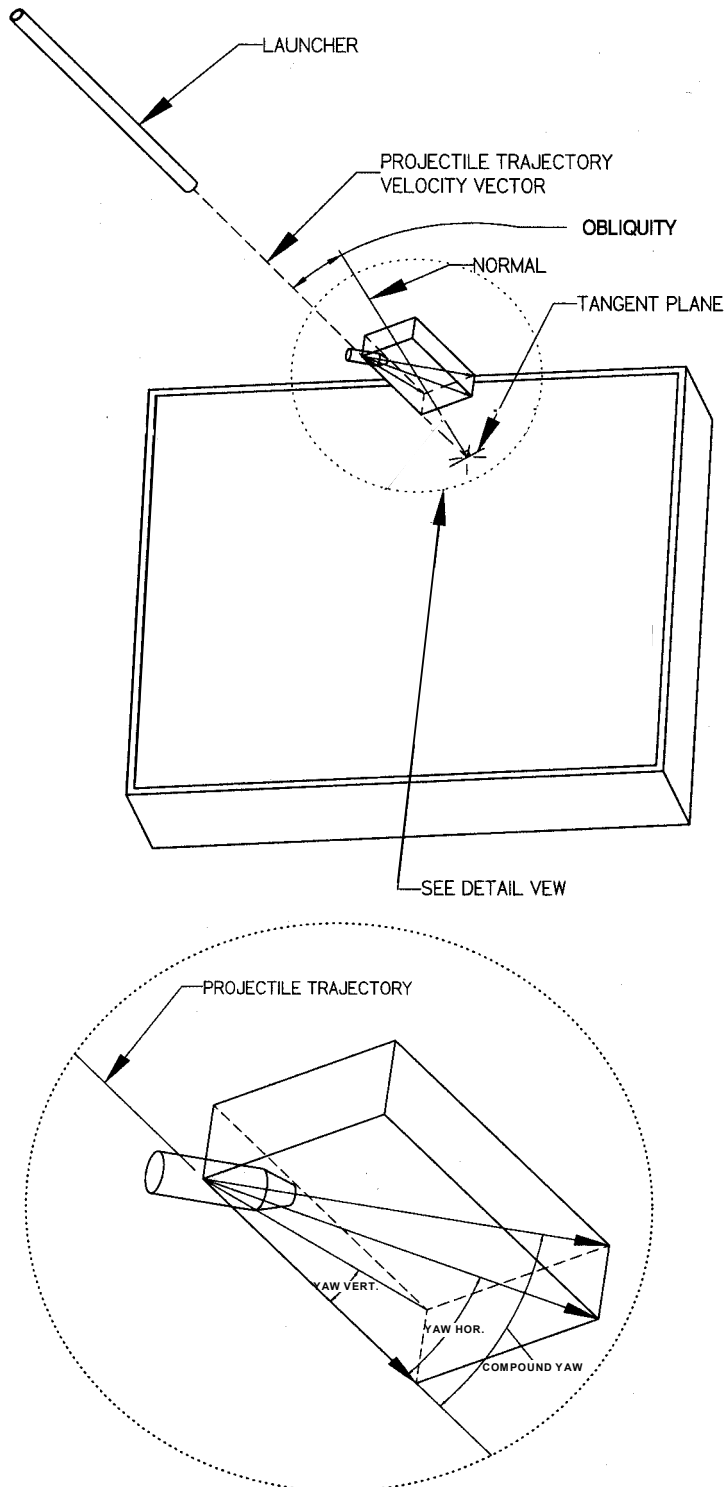

Figure H1 - Angle of impact and yaw

Composite armour: An armour system consisting of two or more different armour materials assembled together to form a protective unit. Not to be confused with composite materials such as GFRP that may form one armour element.

Delamination: The separation of a panel into layers in the thickness direction.

Excluded zone (EZ): The zone allocated around the perimeter of an armour component that is deemed to encompass any Structural Weak Areas present by virtue of the materials, manufacture or joining process employed when fabricated into or attached to the vehicle structure. The area that is not classified as Excluded Zone is the Main Area.

FAIR impact: An impact that meets the specified conditions of velocity, angle of impact, yaw and impact position, within the tolerances defined for each condition (see Para 5.6).

Fragment simulating projectile (FSP): A specific fragment simulator type based on a standardized cylindrical projectile with a chisel nose (see Figures 6 and E2). Available in a homologous size series. Designed to be capable of gun firing to simplify armour testing.

Fully engineered target: An armour configuration fully representative of final vehicle production configuration, i.e., having the same geometrical construction, materials and total areal density. These targets could be panels or mock-ups of vehicle components containing welds or overlaps, etc.

Impact location: The impact location is defined to be at the centre point of the impact.

Main Area armour: A component of representative relatively uniform area of an armour that may include Localized Weak Area.

Opaque armour: Any protection system through which vision is not possible (see Transparent armour).

Partial penetration (PP): A projectile impact that does not result in light being visible through the WP.

Protection capability or Expected protection capability (EPC): The potential of a protection system to resist an attack. The protection capability may be expressed as the probability that the occupants survive without injuries during a particular attack scenario. The protection capability is related to the ballistic resistance of the protection components and the impact probability of those components.

Protection Level: The degree of protection defined in the STANAG 4569. The Protection Levels are defined as threats with conditions specified in ANNEX A of this AEP-55 to STANAG 4569. To be declared compliant to a certain STANAG 4569 Protection Level, the protection system of a logistic or light armoured vehicle shall demonstrate adequate protection capability when evaluated with the threats under the conditions specified.

Relative Vulnerable Area (RVA): The ratio of unprotected (vulnerable) area (A_U) over the total threatened area (A_O) of a protection system.

Shall: A statement that makes the associated requirement in this document fully mandatory.

ANNEX I
AEP-55, Volume 1
(Edition 1)

Shatter gap: The reduction in velocity range over which a projectile may exhibit a distinct change in its characteristics of interaction with a target, from projectile shatter to projectile remaining intact. This may cause the armour to exhibit multiple V_{50} values. The significance for armour testing is to ensure that complete penetration does not occur at lower velocities by the intact projectile that is otherwise fractured and defeated by the target at higher impact velocities.

Shot location witness: A suitable measurement technique to provide evidence of the exact impact point in relation to the intended shot location (see Figure 5) of the projectile. It is used to assess impact fairness for multiple hit testing (see Yaw card).

Should: A statement that makes the associated requirement in this document not fully mandatory, but highly recommended.

Spall: The material detached and ejected of a layer of armour material from the rear surface of the armour. Spall can be produced by both perforating and non-perforating impact of a projectile on an armour panel.

Strike face: The surface of a test target designed to face the attack of a ballistic threat.

Striking or impact velocity (V_s): The velocity of the projectile upon impact with the target face.

System acceptance testing: The process, including ballistic testing of components (Phases 2 and 3) and Vulnerable Area assessment (Phase 4) performed on a vehicle armour system to assess its capability to achieve a given Protection Level.

Target distance: The distance between the muzzle of the test launcher barrel and the strike face of the target (see Figure 5).

Test series: All the impacts required to assess the ballistic performance of one component / threat combination.

Transparent armour: Any protection system through which vision is possible (see Opaque armour).

UNFAIR impact: A shot not conforming to one or more of the specified conditions (velocity, angle of impact, yaw and impact position) (see Para 5.6).

V_{50} ballistic limit: The striking velocity at which 50% of the impacts of a projectile will result in complete penetration of a given armour on specified attack conditions.

Vehicle target: An armour system that may be a fully functional vehicle, or a ballistic structure (vehicle without non-armour related components such as power packs, fire control, etc.).

Vision Block: A narrow aperture made of a transparent material in an armoured vehicle to allow the crew to see outside the vehicle. The small width of the aperture requires the crew to position their eyes very near the block to effectively see outside. Vision blocks need to be tested with thinner witness plates in closer proximity to the test target to reproduce typical ocular conditions.

V_{proof}: The minimum nominal velocity specified for a particular projectile for a pass / fail or acceptance test where a given number of rounds are fired at a test specimen and where no complete penetration is allowed in the initial qualification test series. An increase in the number of **V_{proof}** rounds fired will improve the statistical confidence in the result.

Vulnerable Area (VA): The surface area of a component found not protective according to the STANAG 4569 criteria. The Vulnerable Area is accounted in the calculation of the Relative Vulnerable Area.

Weak Areas: The zones of an armour system that potentially reduce the expected ballistic resistance of a protection system. Two types of Weak Areas, Structural and Localized, are defined below:

- Structural Weak Areas (SWA) are armour zones inherent in the design that differ from the uniform Main Areas and are usually associated with discontinuities in the armour system. These include openings, holes, gaps, welds (including heat affected zones) and joints between major armour panels, bolts and edges, overlaps, etc. Structural Weak Areas are assumed for the purpose of the assessment to be located within the Excluded Zone and are excluded from the armour Main Areas, and thus shall be tested separately (Phase 3).
- Localized Weak Areas (LWA) are smaller potential weak areas included in the armour Main Areas. They could be inherent in the design such as mosaic tile joint, small holes or other geometric features uniformly distributed on armour panel main surfaces. They could also be defects that are not visually detectable to eye examination such as flaws, cracks, inclusions, voids, porosity, and limited delamination

Witness plate: A material sheet placed behind a target impact area to indicate the effects of debris caused by the projectile impact.

Yaw angle: The maximum resultant angle between the main axis of the projectile and its trajectory (velocity vector) irrespective of plane (see Figure H1).

Yaw card: A material placed in the projectile's line of flight, whose perforation signature is used to determine the projectile yaw. The yaw card can also be used as impact location witness sheet (see Figure 5).

REFERENCES – RELATED DOCUMENTS

1. Chang, A.L., and B.A. Bodt, "JTCG/AS Interlaboratory Ballistic Test Program – Final Report", Army Research Laboratory Report no. ARL-TR-1577, Dec. 1997.
2. Fortier, C., D. Bourget, and G. Pageau, "Comparative Study of Selected Methods for Estimating Ballistic Limit Velocities of Armour Materials", Proc. 17th Int. Symposium on Ballistics, Pretoria, South Africa, Mar. 98.
3. Kneubuehl, B.P., "Improved Test Procedure for Body Armour, Statistical Base and Evaluation Program", Proc. PASS96 Symp. Colchester, UK, Sept. 1996.
4. Tobin, L., "The Draft Revised Version of STANAG 2920", Proc. Soldier Modernisation Seminar, 24/25 Oct. 1996, Ottawa, Canada
5. NATO DRAFT STANAG 2920, (draft Ed. 2) "Ballistic Test Method for Personal Armour Materials and Combat Clothing", Oct. 1996.
6. STANAG 4164, "Test Procedures For Armour Perforation Tests Of Direct Fire Armour Defeating Ammunition", Apr. 97.
7. MIL-P-46593A, "Projectile, Calibers .22, .30, .50 and 20MM Fragment Simulating", 12 Oct. 1964.
8. International Test Operating Procedures, USATECOM ITOP 2-2-713 "Ballistic Tests of Armor Materials".
9. International Test Operating Procedures, USATECOM ITOP 4-2-805, "Projectile Velocity and Time of Flight Measurements".
10. U.S. Army Test Operating Procedures, USATECOM TOP 10-2-506, "Ballistic Testing of Personnel Armor Materials".
11. U.S. Government Printing Office, "**V**₅₀ Ballistic Test for Armor", MIL-STD-662F, Feb. 1998.
12. MIL-STD-810F, Environmental Test Methods and Engineering Guidelines, January 2000.
13. STANAG 2895, Climatic Environmental Conditions Affecting the Design of Material for use by NATO Forces, NATO 1992.
14. ASTM E94, Guides for Radiographic Testing
15. ASTM E142, Method for Controlling Quality of Radiographic Testing.
16. Gander, T.J., and Hogg, I.V., (eds), Jane's Ammunition Handbook, 4th edition, Jane's Information Group, 1995.
17. Security Classification Guide for Armor Materials, ARL Program No. 0183009.
18. Bosik, A. J., Bosik, T. A., Pageau, G., *Development of Test Procedures for Multi Hit Testing of Body Armour*, Proceedings of the Personal Armour System Symposium 2000 (PASS 2000), 5-8 Sept. 2000, DCTA Colchester, UK, 7 p.

ANNEX I
AEP-55, Volume 1
(Edition 1)

19. Bourget, D., and Pageau, G., *Armour Data Recording and Analysis Software: Capability Overview*, Proceedings of the Personal Armour System Symposium 2000 (PASS 2000), 5-8 Sept. 2000, DCTA Colchester, UK, 8 p.
20. International Test Operating Procedures, USATECOM ITOP 2-2-716, Measurement of Behind Armour Debris.
21. Gonzalez, R., *Confounding Effects in Light Armor Ballistic Testing*, Proc. Aeroballistic Range Ass. Meeting, Madrid, Spain, 2000, 12 p.
22. Graves, J.H., Kolev, H. Joint Technical Coordinating Group on Aircraft Survivability Interlaboratory Test Program, Rept no. ARL-TR-755, June 1995, ADA 297279, 38 p.
23. U.S. Army Test Operating Procedures, USATECOM TOP 2-2-715, Protection of Armored Vehicles Against Kinetic Energy Projectiles.
24. International Test Operating Procedures, USATECOM ITOP 2-2-617, Vulnerability Testing of Combat Vehicles and Their Components
25. Mackiewicz, J., Ballistic Test Procedures and Protocol for Military Body Armour, U.S. Army, Soldier and Biological Chemical Command, Natick, Draft Report, Jan. 1999.
26. Vaivads, R., Maillette, J., McKeown, M., Characterization of Shot Patterns from Automatic Weapons in Support of the Development of a Multi-Hit Ballistics Test Procedure, Phase 1: Task B, Experimental Assessment of Shot Patterns, Royal Military College, Kingston, Mech. Eng. Report, no. 010101, Jan. 2001.
27. Vaivads, R., Maillette, J., McKeown, M., Characterization of Shot Patterns from Automatic Weapons in Support of the Development of a Multi-Hit Ballistics Test Procedure, Phase 1: Task A, Threat Survey, Selection and Acquisition, Royal Military College, Kingston, Mech. Eng. Report, no. 000601, Jan. 2000.
28. NATO AC/225 Panel III Sub-Panel 5, Collaborative Research into Small Arms Technology, (CRISAT) Technology Area 2: Terminal Effects, Final Report, July 1993, NATO Unclassified, Appendix 4, *Test Specification for Assessing Target and Behind Target Effects of Small Arms Kinetic Energy Ammunition*, Addendum A V_{50} Test Method.
29. Lok, Tat-Seng, Performance of Laminated Glazing Subjected to Small Arms Ballistics, Proc. Specialty Symposium on Structures Response to Impact and Blast (SRIB), Oct. 1996, Tel-Aviv, Israel.
30. AS2343, Pt.1, 1983, Glazing panels: Bullet-resistant panels for interior use, Standards Association of Australia, Sidney, Australia, 1983.
31. ASTM F1233-89, Standard Test Method for Security Glazing Materials and Systems, American Society for Testing and Materials, USA, 1989.
32. BS5051, Pt. 2, Security Glazing: Specification for Bullet-Resistant Glazing for External Use, British Standards Institution, London, 1979.
33. Strassburger, E., Test and Evaluation Procedures –Artillery Threat, document for STANAG 4569, Ernst Mach Institute (EMI), 15 Mar. 2002.

34. Gonzalez, R., Ballistic Multi-hit Standard for STANAG 4569 Levels 1-3, document for STANAG 4569, US Army Tank-automotive and Armament Command, May 2002.
35. Hodak, A., Shot Spacing Discussion Paper, document for STANAG 4569, Canadian Directorate for Land Requirements, 5 Jan. 2003.
36. Underwriters Laboratories, Standard for Safety of Bullet-Resisting Equipment, UL 752, 10th Ed., Mar. 10, 2000.
37. UNI EN 1063, Security Glazing – Testing and Classification of Resistance Against Bullet Attack, 2001.
38. Vaivads, R., Characterization of Shot Patterns for a 14.5 mm HMG, Royal Military College, Kingston, Mech. Eng. Report, no. 030301, Mar. 2003
39. Gonzalez, R., Multi-Hit Testing Procedure for the Ballistic Testing of Armor Against 14.5mm Heavy Machine Gun, US Army Tank-automotive and Armament Command, Mar. 2003.