



Task 1.4.3

Using S3D to Analyze Ship System Alternatives for a 100 MW 10,000 ton Surface Combatant

Submitted to:

Kelly Cooper
Office of Naval Research

Prepared by:

Rich Smart (USC)
Julie Chalfant (MIT)
John Herbst (UT)
Blake Langland (USC)
Angela Card (MSU)
Rod Leonard (USC)
Angelo Gattozzi (UT)

Contract Number:

N00014-14-1-0696 (MIT)
N00014-14-1-0668 (USC)
N00014-14-1-0196 (UT)
N00014-14-1-0168 (MSU)

For further information, please contact
Julie Chalfant, chalfant@mit.edu

For access to S3D and the models in this report, please contact
Blake Langland, langland@engr.sc.edu

April 2017

CONTENTS

Executive Summary	4
1 Introduction	5
2 Smart Ship Systems Design (S3D) Overview	6
2.1 System Design.....	6
2.2 Mission Analysis	7
2.3 Parsing Results.....	7
2.4 Integration with LEAPS	10
3 Ship Design	11
3.1 Ship Requirements and Mission Loads.....	11
3.2 ASSET Run	12
3.3 S3D Initialization	14
3.3.1 Structure Modeling	14
3.3.2 Payload Modeling	14
3.3.3 Zonal Loads.....	16
3.3.4 Support System Equipment.....	16
4 Design Variants.....	16
4.1 Baseline Design	16
4.1.1 Electric Power Distribution.....	16
4.1.2 Power Conversion	19
4.1.3 Thermal Management System.....	21
4.1.4 Gas Turbine Engine Specific Fuel Consumption	22
4.1.5 Equipment Arrangement / 3D Visualization	24
4.2 Design Variant 1: High Speed Power Generation	24
4.3 Design Variant 2: Advanced Materials	25
4.4 Design Variant 3: Alternate Topology	26
4.5 Design Variant 4: Mechanical Electrical Hybrid	29
5 Design Evaluations	30
5.1 Weight.....	30
5.2 Volume.....	32
5.3 Number of Components.....	33
5.4 Power Demand, Cooling Required and Fuel Consumption.....	33
5.5 Range	37
5.6 Uncertainty.....	38
6 S3D Advances and Recommendations	39
6.1 Equipment Models	39
6.2 Process.....	40
6.3 Recommendations.....	41
6.3.1 Electrical Designer: Cable Calculator	42
6.3.2 Piping Designer	42
6.3.3 Mechanical Designer	42
6.3.4 HVAC Designer	43
6.3.5 Naval Architecture Designer	43
6.3.6 Mission Module and Controls	43
6.3.7 Data Availability, Scalable Models, Verification and Validation.....	44
6.3.8 Aggregated Loads and Assemblies	45

6.3.9	Margins, Allowances, Uncertainty and Risk.....	45
6.3.10	Semi-Automated Design Assistance	46
7	Summary	47
8	References	47
	Appendix A: Roles.....	49
	Appendix B: Payload Equipment Details	51
	B.1 Payload Assumptions	51
	B.2 Railgun	52
	B.3 LASER.....	53
	B.4 Active Denial System.....	53
	B.5 Vertical Launching System (VLS).....	54
	B.6 Dual Band Radar	54
	B.7 InTop Array.....	55
	B.8 Sonar.....	55
	B.9 Total Ship Computing Environment	55
	B.10 Helicopters.....	56
	B.11 Boats	56
	B.12 References	56
	Appendix C: Baseline System Diagrams from S3D.....	58
	Appendix D: Equipment Help Files Examples	61
	D.1 Pump Flow Rate.....	61
	D.1.1 Functionality	61
	D.1.2 Fault Modeling	61
	D.1.3 Analytical Methods	62
	D.1.4 Data	62
	D.1.5 User Guidelines	62
	D.2 Motor	63
	D.2.1 Functionality	63
	D.2.2 Fault Modeling	64
	D.2.3 Analytical Methods	64
	D.2.4 Data	64
	D.2.5 User Guidelines	65
	D.3 Abbreviations and Acronyms.....	65
	Appendix E: High-Speed Generator.....	66

TABLES

Table 1.	Ship threshold and objective performance requirements.	11
Table 2.	Payload list and maximum electrical power demand in MW at battle condition.....	12
Table 3.	Summation of non-payload electrical and cooling demands at cruise and mission battle conditions.	13
Table 4.	Ship threshold and objective performance.	14
Table 5.	Summary of converter data for 10kV dc to/from 6.9kV ac.	19
Table 6.	Estimated dc to dc power converter dimensions.	20
Table 7.	Converter sizes chosen for the baseline ship.....	20

Table 8. Assumed power level and specific fuel consumption for gas turbine generator sets used in the study.....	23
Table 10: Weights and dimensions of gas turbine generator sets.....	24
Table 11. Multiplication factors for “advanced material” power electronics.	25
Table 12. Weights by SWBS group in ASSET and S3D.....	31
Table 13. Weights in metric tons by SWBS group for each variant.	32
Table 14. Volume in cubic meters.	32
Table 15. Number of components.	33
Table 16. Mission segment alignment summary.	34
Table 17. Mission results.....	35
Table 18. Fuel load for range calculation.	38
Table 19. Range and steady state power demand results for range mission.	38
Table 20. Results for test of uncertainty.	39

FIGURES

Figure 1. Design Dashboard showing component weight breakdown by equipment category for baseline design.	9
Figure 2. Design Dashboard showing component weight breakdown by equipment category for high speed generator design variant. Note the reduction in Gas Turbine Generator Set weight for this design.	9
Figure 3. Project Dashboard View, comparing total weight for each of four variants.....	10
Figure 4. Hybrid constant current/constant power charging profile for the EM Gun system.	15
Figure 5. Baseline Electrical Distribution System Diagram.....	17
Figure 6. Gas turbine ratings used for operation in electrical simulations [GE Marine 2014, LM2500+G4 (left), LM500 (right)].	18
Figure 7. Notional generator efficiency as a function of power level.	18
Figure 8. Baseline thermal management system.	22
Figure 9. Effect of ambient temperature and air to fuel ratio on heat rate [Rahman et al. 2011].....	23
Figure 11. U.S. Navy Proposed MVDC Architecture [Doerry 2016].	27
Figure 12. Bus Node functional block diagram.....	28
Figure 13. PCM-1A functional block diagram.....	28
Figure 14. Electrical power demand for the baseline design during peacetime cruise (top), sprint to station (center) and on-station battle (bottom), by one-digit SWBS group.	36
Figure 15. Fuel consumed in normal (two-generator) and high-efficiency (single-generator) alignments.....	37

Executive Summary

The Electric Ship Research and Development Consortium (ESRDC) was tasked by the Office of Naval Research (ONR) with using the Smart Ship Systems Design (S3D) software to develop and compare several ship system designs demonstrating key elements of a 100 MW Medium Voltage Direct Current (MVDC) electric power distribution architecture suitable for integration into a future 10,000 ton surface combatant. The goals of this exercise were twofold: first, perform a study of several ship system variants and quantify the differences between the variants; and second, provide user evaluation of the S3D design environment, user-driven refinement of the environment, and improved understanding of the design processes it enables.

The team developed a notional “Baseline Design” with an array of mission loads for a 10,000 ton surface combatant using 10kV dc distribution and conventional silicon-based solid state power conversion. Then, several design variants were developed to explore the impact of alternative topologies and advanced materials. These included:

- High speed power generation
- Advanced materials for solid-state power conversion
- Alternative power system topologies
- Mechanical/electrical hybrid (developed but not evaluated)

Designs were compared for changes in weight, volume, number of components, and range. Additionally, a notional time-based mission consisting of three mission segments was developed to compare the performance of each design variant against an operational vignette; selected results are presented in the report.

In addition to developing notional designs for the 10,000 ton surface combatant, the ship design project provided important feedback to the S3D software development team. The project led to several enhancements of the design tool including new equipment library components, e.g., bus nodes and IPNCs, as well as new functionality, e.g. the mission alignment comparison tool.

Recommendations for future enhancements to S3D as a result of this exercise include semi-automated design assistance; review of the role of margins, allowances, uncertainty and risk, treatment of aggregated loads and assemblies; verification and validation of models and an expanded model library; expansion of the catalog of scalable models; inclusion of high-level controls for mission analysis; and improvements to the individual discipline-specific design tools.

1 Introduction

The Electric Ship Research and Development Consortium (ESRDC) was tasked with using the Smart Ship Systems Design (S3D) software to develop and compare several ship system designs demonstrating key elements of a 100 MW Medium Voltage Direct Current (MVDC) electric power distribution architecture suitable for integration into a future 10,000 ton surface combatant. The goals of this exercise were twofold: first, perform a study of several ship system variants and quantify the differences between the variants; and second, provide user evaluation of the S3D design environment, user-driven refinement of the environment, and improved understanding of the design processes it enables.

S3D was used to develop multiple designs for a notional 10,000 ton surface combatant using a fully integrated Medium Voltage Direct Current (MVDC) electric power distribution architecture to support an array of advanced mission loads.

The technical approach was to select a 10,000 ton displacement hull form and define a set of ship requirements to guide the designs. A baseline system design using conventional power system architectures, currently available power generation, and power conversion technologies was then developed to assess feasibility and provide a benchmark for comparison of variant designs; this is termed the baseline design.

Guided by the information available in an open-source format and the desire to exercise the current capabilities of the S3D software, four variants were selected for further exploration beyond the baseline: high-speed turbine generator sets, advanced material converter technology, revised power system topology, and a mechanical/electrical hybrid. These variants provided an exercise of the environment with one fairly simple design change (replacing turbine generator sets with high-speed units), one equipment change with cascading effects (advanced material converter technology), one arrangements change (revised topology), and one example of a significantly different technology that affects multiple systems (mechanical-electrical hybrid).

The variants accomplished in this study pave the way for possible interesting follow-on studies that could be accomplished by drawing from the expertise available and the new technologies under exploration within ESRDC. Several possible system variants are postulated for further exploration:

- Advanced thermal concepts including two-phase cooling
- High-temperature superconducting cables and machines
- Energy magazine concept development
- Alternate hullforms

All ship designs were developed in S3D to exercise the developmental early-stage design tool and provide feedback on the S3D design environment and the impact of S3D on the ship design process.

The remainder of the report is organized as follows:

- Section 2 provides an overview of the S3D design environment.
- Section 3 describes the initialization of the ship design.
- Section 4 describes the baseline design and the variants.
- Section 5 presents the evaluations of the variants.
- Section 6 discusses recommendations for future upgrades to the S3D environment.
- Section 7 presents a summary of the report findings and recommendations.

Appendices provide details regarding roles of participants, payload equipment selections, screenshots of the designs in S3D, example help documents from S3D, and equipment sizes and locations in the baseline ship.

2 Smart Ship Systems Design (S3D) Overview

S3D is a comprehensive engineering and design environment capable of performing early concept development and concept comparison (weights, power demand, etc.), and high-level ship system tradeoff studies, as described in [Langland et al., 2015].

2.1 System Design

The current S3D environment contains tools for the development and simulation of the electrical, piping, and mechanical ship systems and the arrangement of the system components in the 3D ship model. S3D is currently capable of static power-flow simulation for all major disciplines.

The S3D environment currently includes the following design tools:

- Equipment library – A relational database tool that houses a set of notional and commercial off-the-shelf equipment that can be rapidly integrated into a ship design.
- Naval Architecture Designer– A 3D visualization tool that permits the arrangement of equipment within a ship hull model ensuring physical fit of the conceptual design.
- Mechanical Designer– A tool that enables the design and simulation of mechanical support systems.
- Electrical Designer – A tool that enables the design and simulation of electrical support systems.
- Fluid Cooling Designer – A tool that enables the design and simulation of fluid cooling support systems.

The design tools are integrated such that changes in one discipline, once saved, are reflected in the other disciplines. Similarly, the simulation results from one tool are propagated to the other

disciplinary tools. The static power-flow simulators provide steady state values such as electrical power produced or consumed, voltages, currents, fluid temperature, torque, etc.

2.2 Mission Analysis

In addition to the system design tools described above, the S3D design environment includes modules for the analysis of a design against a mission, thus facilitating performance comparisons between designs based on achieving the required mission parameters and overall fuel consumption.

As described in [Langland et al., 2015], a mission is defined independently from any specific ship design allowing for a suite of missions to be defined in a general way and permitting the evaluation of any number of designs against a standard set of missions. A mission consists of a sequence of mission segments and associated operating states.

The Mission Designer is used to configure a mission with one or more mission segments in a non-ship-specific manner, including such information as operational states, ship speed, duration, and environmental factors. The Mission Designer also specifies how the S3D Mission Analyzer will react to mission events such as depleted energy storage devices or tripped breakers over the course of a mission.

The Mission Analyzer can either co-simulate all disciplines of a specific design with fixed speed, duration, and system alignments, or co-simulate all disciplines for one or more design(s) against a mission. The first analysis automatically cycles through all the design tools, performing a simulation in each until the simulations converge. The second analysis runs one or more designs through a mission designed in the Mission Designer tool, first prompting the user to ensure that the ship design to be evaluated is configured properly for the operational state and speed defined for each mission segment.

2.3 Parsing Results

S3D includes tools to view results for a single design or to compare the results of multiple designs. The Design Dashboard allows the user to parse metrics and simulation results for a single design; the Project Dashboard performs a similar function for multiple designs simultaneously. These tools facilitate the in-depth investigation of ship designs created in S3D.

The Design Dashboard is used to sort and display design data for both the underlying design configuration as well as the results of the design's performance against mission segments as described in the section on Mission Analysis. The Design Dashboard also presents General Design Characteristics which summarize the Electrical, Machinery, and Thermal system designs. Information presented in the Design Dashboard is useful for evaluation of a specific design or comparison of multiple designs against a common set of missions. The data can be filtered by discipline (e.g., electrical, mechanical, etc.) and grouped by equipment category or one-, two-, or three-digit SWBS number. SWBS (Ship Work Breakdown Structure) is a categorization system

used by the Navy that organizes information or components by shipboard function [NAVSEA]. Data displayed includes: air cooling required, liquid cooling required, cost, electrical power demand, electrical power supplied, mechanical power supplied, mechanical power demand, weight, volume and ship work breakdown structure (SWBS) category.

Figure 1 below shows the design dashboard configured to display a breakdown of component weights by equipment category; Figure 2 shows the same information for the high speed generator design variant. Note the significant reduction in Gas Turbine Generator Set weight from 372,954 kg to 165,213 kg in the high speed generator design variant.

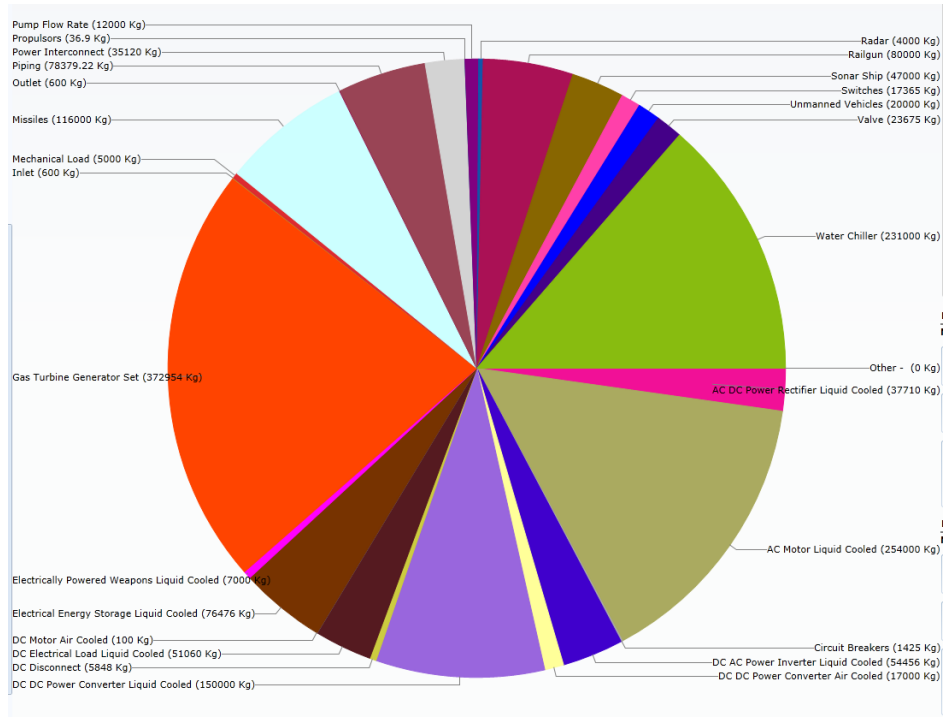

Figure 1. Design Dashboard showing component weight breakdown by equipment category for baseline design.

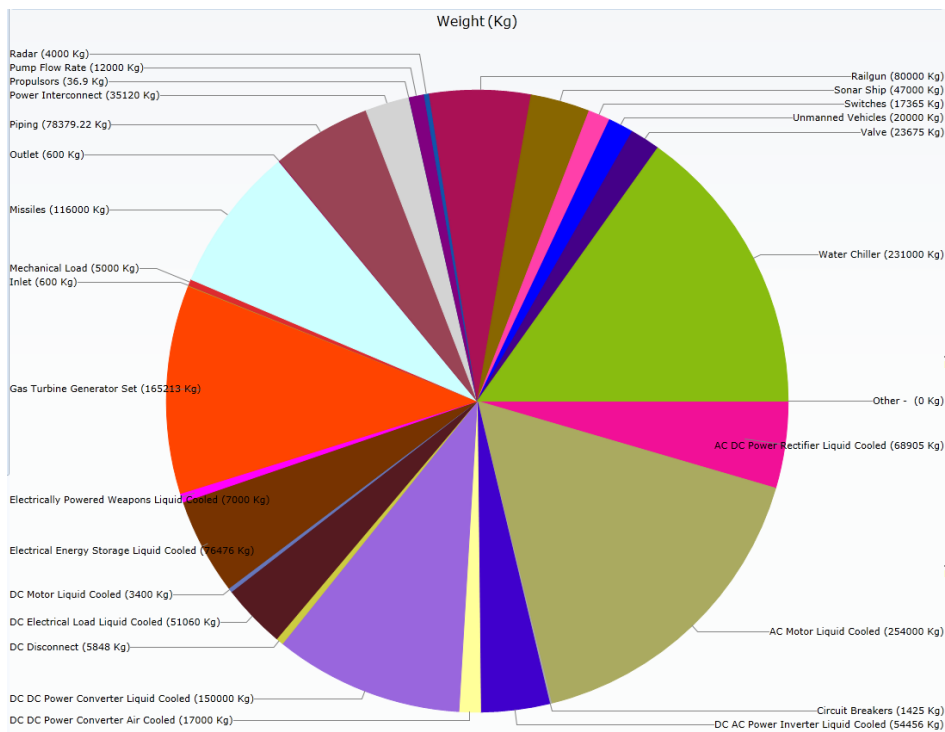

Figure 2. Design Dashboard showing component weight breakdown by equipment category for high speed generator design variant. Note the reduction in Gas Turbine Generator Set weight for this design.

In addition to investigating individual designs using the Design Dashboard, it is possible to compare results across multiple designs using the Project Dashboard, which has similar capability to the Design Dashboard in the ability to view, sort and parse data and results across multiple designs simultaneously. This tool allows investigation into the data since the information can be sorted, filtered and displayed in many ways. As an example, Figure 3 shows a comparison of total weight for each of the four main variants.

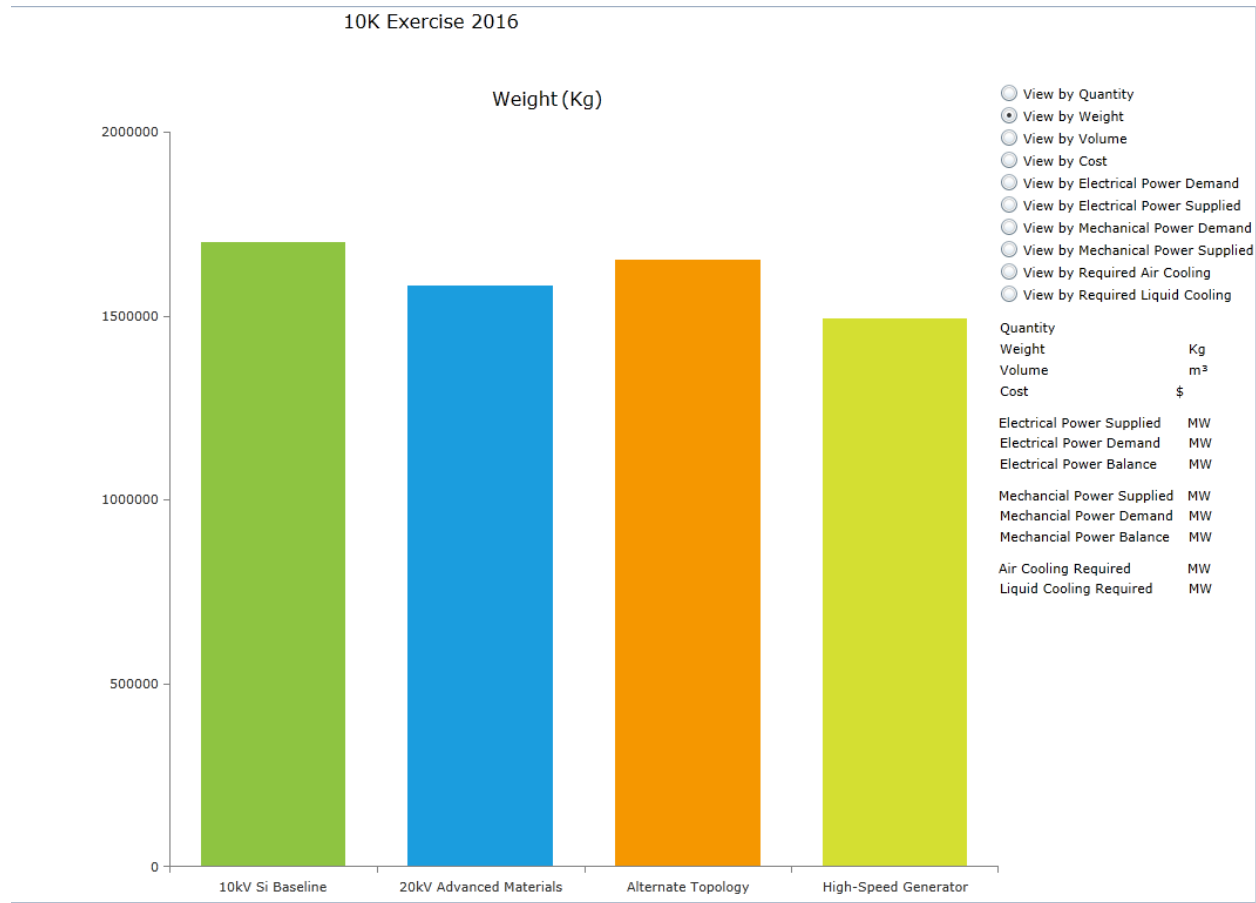

Figure 3. Project Dashboard View, comparing total weight for each of four variants.

2.4 Integration with LEAPS

A project is currently underway within ESRDC to integrate S3D with the Navy’s suite of design tools so that required data is available in the Navy’s design data repository, LEAPS (Leading Edge Architecture for Prototyping Systems). Once this integration is complete, information from ASSET will be directly accessible by S3D and any data developed within S3D will be available to the Navy’s suite of design tools. In the interim, and in this project, data must be manually transferred from LEAPS to the S3D data repository. For more information on the integration of S3D with LEAPS, see [Langland et al., 2015], [Ferrante et al., 2015], and [Chalfant 2015].

3 Ship Design

To begin the project, the team developed ship requirements and mission loads, and then created a representative baseline model using ASSET, the Navy’s early-stage ship synthesis tool. Pertinent information was transferred from ASSET to S3D, and the ship systems were fleshed out within the S3D tool to create the baseline ship. Details of these steps are provided below.

3.1 Ship Requirements and Mission Loads

The team developed a set of threshold and objective performance requirements, shown in Table 1, to guide the ship designs and enable comparisons between the variants. Since this is an electric-drive ship in which all installed power can be directed either to propulsion or ship service loads or some combination of each, we found a need to define a performance requirement of “battle speed” in addition to the usual sustained and endurance speeds. Battle speed is defined as the maximum sustained speed that can be attained with weapons and sensors fully engaged.

Table 1. Ship threshold and objective performance requirements.

Parameter	Threshold	Objective
Installed Power	95 MW	100 MW
Displacement	11,000 mt	10,000 mt
Maximum Sustained Speed	27 kts	32 kts
Maximum Battle Speed	25 kts	30 kts
Cruise Speed	14 kts	16 kts
Range	3,000 nm	6,000 nm

To place the design in the realm of future capabilities, we performed a survey of new weapon and sensor technologies in the world’s navies and selected several leading-edge technologies that would tax the power and cooling systems onboard the ship. Using publicly available information, a list of sensors, communications and weapons equipment along with the associated power and cooling system loads, efficiencies, weights and dimensions was compiled. The list of payload equipment with maximum electrical power demand in MW during battle condition is presented in Table 2. Details supporting the equipment selection are included in Appendix B, along with tables delineating the information required for ASSET and S3D.

Table 2. Payload list and maximum electrical power demand in MW at battle condition.

Equipment	Maximum Electrical Power Demand (MW)
Armament	
Railgun	17
LASER	1.2
Active Denial System	2.4
Command and Surveillance	
Multi-Function Phased-Array Radar	5
Integrated Topside (InTop), including Surface Electronic Warfare Improvement Program (SEWIP) and communications	4
Hull Mounted Sonar, Towed-Array Sonar	0.45
Total Ship Computing Environment (Integrated weapons, sensor, machinery and navigation control systems)	0.15
Vehicles	
Helicopter/UAV	0
Small Boats/USV	0

3.2 ASSET Run

A baseline ship was developed using the Navy’s early-stage design synthesis tool, ASSET, with the goal of achieving the mission requirements set forth in Table 1. Decisions made in the initial ASSET design are delineated below:

- A hullform similar to DDG-51 was selected as a starting point. A plug was installed to increase length, and sizing parameters were selected to achieve a hullform that would displace approximately 10,000 mt at an appropriate draft.
- The payload items described above were arranged on a skeleton ship to determine approximate locations, and then entered into the Payload and Adjustments table of ASSET.
- A selection of three LM-2500+G4 engines at 29 MW each and three LM-500 engines at 3.7 MW each produce approximately 98 MW of installed power at Navy ratings. These engines were selected to provide a variety of power levels in different combinations, with the additional goal of totaling to approximately 100 MW. Note that this selection was heavily swayed by the 100MW installed power requirement; there are other combinations of prime movers that may achieve better efficiency and performance for the given ship.
- The generator selection was combined with an Integrated Power System (IPS) and a dc Zonal Electrical Distribution System (ZEDS) using 5 MW power conversion modules (PCMs).

- Two 36 MW permanent magnet motors provide the propulsion power required to achieve the sustained and cruise speeds required.
- The manning complement was selected to be 243 personnel total including the air detachment.

Part of the ASSET process is to produce a balanced hull that meets trim, list, intact and damaged stability, and seakeeping requirements; to achieve this, equipment locations were adjusted along with hullform and superstructure parameters, bulkhead locations, deck locations, etc.

The ASSET run produced information on hull and deckhouse sizing and structure, propulsion power, design endurance range, and the weight, volume, electrical and cooling demands of all non-payload items (Table 3). These data provided the input information required to begin the S3D system design and arrangements.

Table 3. Summation of non-payload electrical and cooling demands at cruise and mission battle conditions.

Equipment Name	Cruise Electrical Load (KW)	Mission Electrical Load (kW)	Cruise Cooling Load (KW)	Mission Cooling Load (KW)
Vital Loads				
Zone 1	622	788	248.8	315.2
Zone 2	761	1013	304.4	405.2
Zone 3	761	1013	304.4	405.2
Zone 4	751	916	300.4	366.4
Non-vital Loads				
Zone 1	293	163	117.2	65.2
Zone 2	371	191	148.4	76.4
Zone 3	378	199	151.2	79.6
Zone 4	382	163	152.8	65.2

The ASSET algorithms are parametrically based on historical data, so the ship produced by ASSET assumes existing and past technology. We postulated that a ship design requiring 100 MW of power would not fit in a 10,000 mt hull using traditional equipment and distribution systems; we were able to achieve 10,000 mt, but were only able to store enough fuel for a design endurance range of 50 nautical miles, which is clearly unacceptable. By incorporating new technologies in the design through the use of S3D the team analyzed the ship variants to determine whether the weight and volume of support systems can be reduced and fuel load increased to the point that range can be increased to a reasonable distance. See Table 4 for the results of the initial ASSET run.

Table 4. Ship threshold and objective performance.

Parameter	Threshold	Objective	ASSET
Installed Power	95 MW	100 MW	99 MW
Displacement	11,000 mt	10,000 mt	10,000 mt
Maximum Sustained Speed	27 kts	32 kts	30.5 kts
Maximum Battle Speed	25 kts	30 kts	27 kts
Cruise Speed	14 kts	16 kts	15 kts
Range	3,000 nm	6,000 nm	49.8 nm

3.3 S3D Initialization

The next step was to transfer pertinent information from ASSET to the S3D model.

3.3.1 Structure Modeling

The hullform was recreated for the design exercise in QinetiQ's Paramarine[®] Naval Architecture Design and Analysis Tool [QinetiQ] to produce a format that was readable by S3D; this step will be obviated by the LEAPS integration project currently underway. Using the hullform parameters from ASSET such as length, beam, prismatic coefficient, maximum section coefficient and waterplane coefficient, a hullform and superstructure were created in Paramarine that were similar to but not exactly like the hullform and superstructure created in ASSET. This meshed ship structure was exported as a .stl file for import into the S3D tool. The deck and bulkhead locations were taken from ASSET and manually input into S3D. Within the current version of S3D, there is no deck camber or shear; decks are planes parallel to the xy plane.

3.3.2 Payload Modeling

Each weapon and sensor is modeled as an individual component in S3D. Support equipment for each payload item is modeled as a single amalgamated component, thus separating the weight, volume, and losses for the support equipment from those of the weapon or sensor itself. The efficiency of the support equipment is set to generate losses (and thus heat) in the proper location for the thermal management system to handle. As an example, the radars are assumed to be 30% efficient overall; however, some of the losses occur at the radar face and some occur in the radar support equipment. The S-band radar array modeled in S3D for this project draws 1250 kW total from the system. The radar array was set to 750 kW at 50 percent efficiency, generating 375 kW of heat at the radar face. The radar support equipment was set to 60% efficiency, so it draws 750 kW/.6 or 1250 kW from the electrical distribution system and generates .4*1250 kW or 500 kW of heat at the location of the support equipment. Thus, total power drawn by a single S-band

radar array is 1250 kW, and total heat generated is 875 kW, which is 70% of 1250 kW, but the heat is generated in the proper location for the thermal management system to handle. Also of note is that the support equipment may actually consist of many separate individual consoles, but is modeled in S3D as a single block with a total weight and size that accommodates all the support equipment items along with required positioning and clearance.

Mission Loads: Electromagnetic Railgun System

Beyond propulsion loads, the Electromagnetic Railgun (EMRG) system represents the largest mission load supported by the ship's electric power distribution system. The EMRG is designed to deliver high-current pulses to the breech of the gun at a repetition rate of 10 shots per minute. The baseline design provides the high-current pulses by using four high-voltage capacitor bank modules. The capacitor modules are charged by four dc charging power supplies (effectively dc-dc converters) which represent the load actually seen by the ship's power system. Based on prior work under the ONR-sponsored Hybrid Energy Storage Module (HESM) program [University of Texas, 2014], the charging profile (Figure 4) for the capacitor modules is assumed to be a hybrid constant current/constant power profile that provides a balance between charging efficiency and peak charging power. A separate energy storage module is used to buffer the transient load seen by the ship's power system, absorbing and supplying power to maintain an essentially constant load on the ship power system. Based on projected system efficiency and the objective 32 MJ projectile kinetic energy, during maximum repetition rate operation the average power draw of the EM gun system is approximately 17 MW.

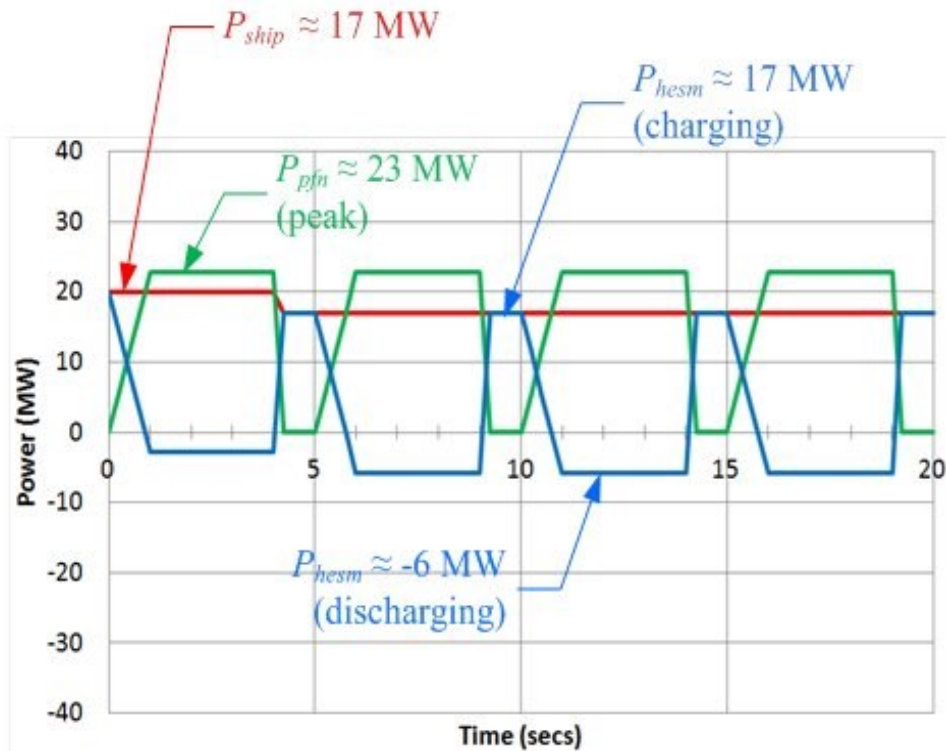

Figure 4. Hybrid constant current/constant power charging profile for the EM Gun system.

Due to the short duration of the railgun discharge, the high current pulses associated with the gun firing are not considered in the S3D analyses.

The size and weight of the capacitor bank modules used in the baseline design are scaled from a 2003 study of a capacitor-based pulsed power system designed to provide 64 MJ of kinetic energy in the projectile [Bernardes et al., 2003]. The energy storage subsystem for the EMRG system is based on current ONR-sponsored work on high-speed rotating machines for energy storage.

3.3.3 Zonal Loads

To limit the complexity of the electrical and thermal management system schematics, ancillary zonal hotel and service loads were aggregated into vital and non-vital classes fed from dedicated zonal converters. Table 3 summarizes the vital and non-vital electrical loads and the associated thermal load on the cooling system; individual vital and non-vital loads were created for each zone with appropriate electrical demand and efficiencies to generate the appropriate cooling demand. These loads were centrally located in the zones, uniformly sized, and given a weight of zero.

3.3.4 Support System Equipment

The major equipment items generated by ASSET that were imported to S3D included the drivetrain (motor, shaft, and propeller), gas turbine generator sets, and HVAC air conditioning units (chillers). None of the electrical distribution system equipment that was generated by the ASSET machinery module was imported to S3D since it is based on outdated algorithms; instead, an entirely new electrical distribution system was created within S3D, appropriately parameterized to supply the loads.

4 Design Variants

4.1 Baseline Design

The baseline design was constructed using conventional power system architectures and currently available power generation and power conversion technologies to assess feasibility and provide a benchmark for comparison with variant designs.

4.1.1 Electric Power Distribution

The baseline power distribution architecture is a conventional split ring bus with four distribution zones. A simplified block diagram of the distribution system is shown in Figure 5; a detailed rendering is shown in Figure C.1 of Appendix C.

Due to the practical limitations of currently available silicon-based solid state switches, the primary distribution voltage was limited to 10 kV (± 5 kV dc) for the baseline design. Power is generated at 6.9 kVac; rectifiers co-located with each generator immediately convert power to the distribution voltage of 10kVdc. Generators are connected to the ring bus on the side closest to the physical location of the generator, providing dual power paths through the fully connected ring bus while also providing separation between sources of power. The plant can be operated in a split-bus configuration by opening forward and aft disconnects in the main ring bus.

Propulsion motors are also connected to the ring bus on the side closest to the physical location of the motor, through a motor drive that provides 15-phase variable-speed ac power to the motors.

High-power mission loads (e.g. EMRG and RADARs) are supplied from both the port and starboard primary distribution buses via dedicated converters co-located with the loads. All other payloads and all vital and non-vital support loads are powered via converters located port and starboard within each zone. Vital loads are connected to both the port and starboard converters, while non-vital loads are provided a single source of power through only one in-zone converter. No cross-connects are provided between zones, so each zone has two sets of in-zone converters.

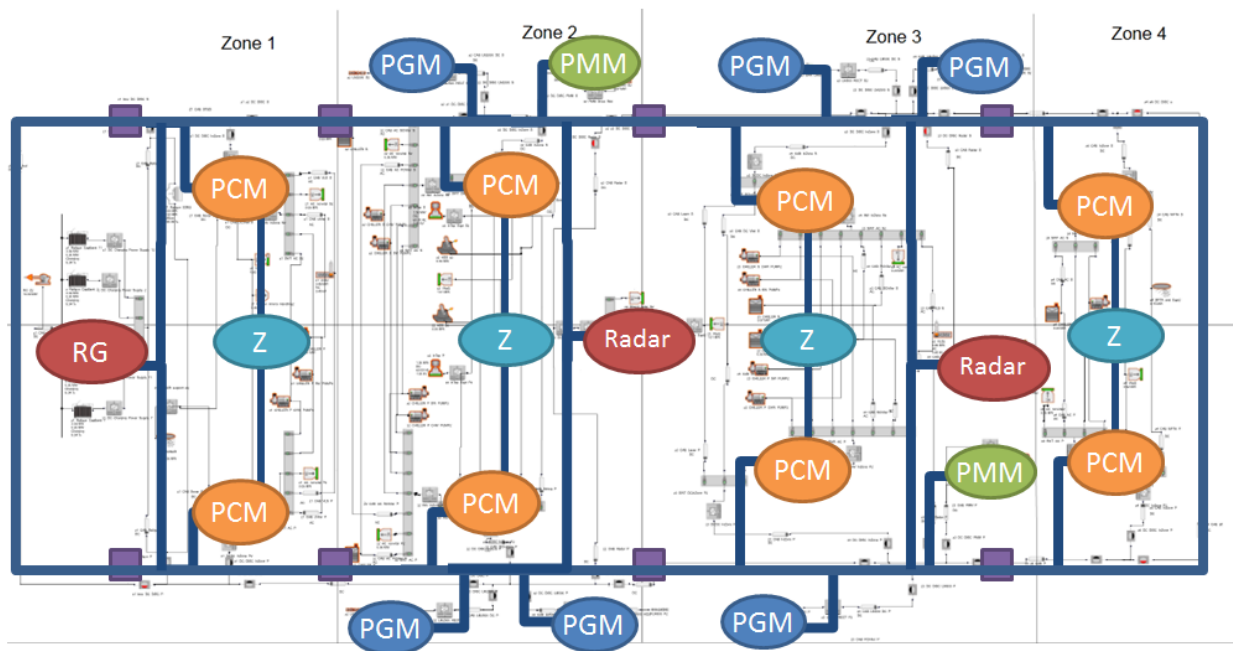

Figure 5. Baseline Electrical Distribution System Diagram. For details, see Appendix C.

Prime power generation is nominally 99 MW and consists of six turbine-generator sets: three LM-2500+G4's nominally rated for Navy operation at 29 MW and three LM-500's nominally rated for Navy operation at 3.7 MW [GE Marine, 2014]. Power ratings for the engines were pulled from published data using ratings at sea level and 100°F with 4 inches/6 inches of water inlet and exhaust losses, respectively; see Figure 6. Specific Fuel Consumption (SFC) curves were created for these engines by linearly downgrading the published SFC curves to operate at

100°F; it was assumed that the 40°F increase in operating temperature caused an approximately 3% degradation in SFC.

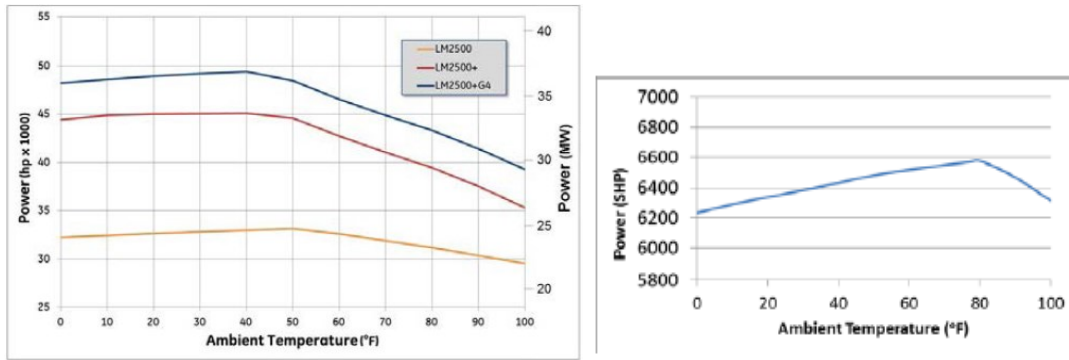

Figure 6. Gas turbine ratings used for operation in electrical simulations [GE Marine 2014, LM2500+G4 (left), LM500 (right)].

A notional percent power versus efficiency curve was generated to enable calculation of the generator thermal loads and define mechanical power requirements for the engines. This curve was used in all of the design variants except the High Speed Generator where slightly lower efficiency is expected. Figure 7 shows the notional curve used for the “baseline” synchronous generators; a 0.5% “penalty” was applied to the high-speed generators.

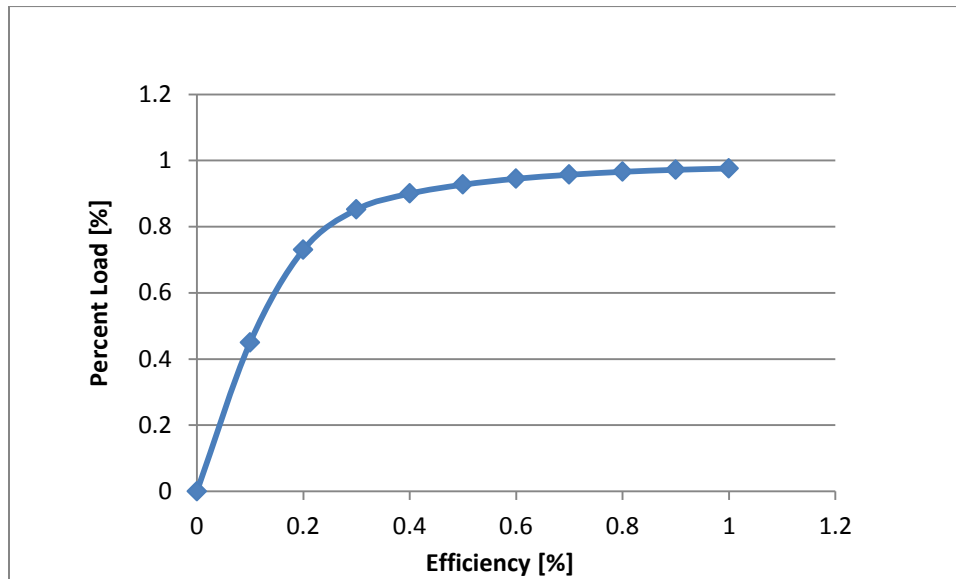

Figure 7. Notional generator efficiency as a function of power level.

Propulsion is provided through two variable speed 36.5 MW permanent magnet propulsion motors; these components are based on a prototype PM motor developed by DRS Technologies [2013].

4.1.2 Power Conversion

Power conversion elements represent a significant portion of the size and weight of the electric power distribution system for the ship designs. Power conversion required in the baseline design includes:

- Rectification of the prime power generation for dc distribution.
- dc-dc converters to step down the primary distribution voltage into the zones and for the RADARs.
- Inverters for in-zone ac loads.
- dc charging power supplies for the capacitor-based pulse forming network.
- Variable speed drives for the permanent magnet propulsion motors.

Dimensions and weights for conventional Silicon power converter units were provided by Ericsen [2014], adapted from [Soltau et al., 2014]. It is assumed that 1 kHz transformers are included internally to the dc-dc converters. Table 5 shows the data for rectifier/inverter power converters; converters would be no larger or heavier than the equivalent converters from Table 5. Weight for the 35 MW rectifier was extrapolated from weights of smaller units; it is recognized that this is unadvisable and better information should be sought for this unit. Final results for the converters chosen to be used in the baseline ship are tabulated in Table 7.

Table 6 shows data for the dc-dc power converters. For the 10 kV (+-5 kV) dc distribution bus design, the converter of the next incremental size was used, selecting data from the two tables for dc-dc transformers and inverters/rectifiers. Several inverters from 1 kVdc to 450 Vac were required at power levels less than 4 MW each; it was assumed that these

Table 5. Summary of converter data for 10kV dc to/from 6.9kV ac.

Power Rating (MW)	Weight (kg)	Length (m)	Depth (m)	Height (m)
6	3720	4	1.6	2.36
8	3780	4	1.6	2.36
10	3900	4	1.6	2.36
12	3960	4	1.6	2.36
14	5610	5.5	1.6	2.36
18	5730	5.5	1.6	2.36
22	6438	6.4	1.6	2.36
24	6618	6.4	1.6	2.36
26	*	7.3	1.6	2.36
28	*	7.3	1.6	2.36
30	*	8.8	1.6	2.36
32	*	8.8	1.6	2.36
34	*	8.8	1.6	2.36

36	*	8.8	1.6	2.36
38	*	9.7	1.6	2.36
40	*	9.7	1.6	2.36

* Asterisks indicate components with insufficient data to determine weight.

converters would be no larger or heavier than the equivalent converters from Table 5. Weight for the 35 MW rectifier was extrapolated from weights of smaller units; it is recognized that this is unadvisable and better information should be sought for this unit. Final results for the converters chosen to be used in the baseline ship are tabulated in Table 7.

Table 6. Estimated dc to dc power converter dimensions.

Converter	Primary Voltage (kV)	Secondary Voltage (kV)	Weight (kg)	Length (m)	Depth (m)	Height (m)
10 MW DCDC	10	1	10000	14	1.6	2.36
5 MW DCDC	10	1	5000	7	1.6	2.36

Table 7. Converter sizes chosen for the baseline ship.

Name	Current Type	Rated Electrical Power (MW)	Rated Primary Voltage (kV)	Rated Secondary Voltage (kV)	Length (m)	Depth (m)	Height (m)	Weight (kg)
LM500_RECT	AC-DC	4.5	6.9	10	4	1.6	2.36	3720
LM2500_RECT	AC-DC	35.3	6.9	10	8.8	1.6	2.36	8850*
PMM_Drive_A	DC-AC	15.0	10	6.9	5.5	1.6	2.36	5730
PMM_Drive_B	DC-AC	22.5	10	6.9	6.4	1.6	2.36	6618
DCDC_Radar_Fwd	DC-DC	3.3	10	1	7	1.6	2.36	5000
DCDC_Radar_Aft	DC-DC	1.7	10	1	7	1.6	2.36	5000
Charging_Power_Supply	DC-DC	5.0	10	20	7	1.6	2.36	5000
z1_DCDC_InZone_P	DC-DC	4.0	10	1	7	1.6	2.36	5000
z1_DCDC_InZone_S	DC-DC	4.0	10	1	7	1.6	2.36	5000
z2_DCDC_InZone_P	DC-DC	8.9	10	1	7	3.5	2.36	10000
z2_DCDC_InZone_S	DC-DC	8.9	10	1	7	3.5	2.36	10000
z3_DCDC_InZone_P	DC-DC	6.0	10	1	14	1.6	2.36	10000
z3_DCDC_InZone_S	DC-DC	6.4	10	1	7	3.5	2.36	10000
z4_DCDC_InZone_P	DC-DC	3.1	10	1	7	1.6	2.36	5000
z4_DCDC_InZone_S	DC-DC	2.7	10	1	7	1.6	2.36	5000
z1_INV_InZone_P	DC-AC	2.1	1	0.45	4	1.6	2.36	3720
z1_INV_InZone_S	DC-AC	2.1	1	0.45	4	1.6	2.36	3720
z2_INV_InZone_P	DC-AC	2.9	1	0.45	4	1.6	2.36	3720
z2_INV_InZone_S	DC-AC	2.9	1	0.45	4	1.6	2.36	3720
z3_INV_InZone_P	DC-AC	3.3	1	0.45	4	1.6	2.36	3720
z3_INV_InZone_S	DC-AC	3.7	1	0.45	4	1.6	2.36	3720

z4_INV_InZone_P	DC-AC	1.8	1	0.45	4	1.6	2.36	3720
z4_INV_Inzone_S	DC-AC	1.3	1	0.45	4	1.6	2.36	3720

* Asterisk denotes extrapolated value.

4.1.3 Thermal Management System

The thermal management system, illustrated in Figure 8, consists of a ring header with parallel supply and return lines. Six 1,100-ton chiller units are divided into four zones; this number of units resulted from the ASSET run which takes into account both water-cooled and air-cooled equipment along with personnel and ambient loads.

Branches for each zone plus branches for rail gun, radars, and propulsion loads group the cooling loads. Piping elements consist of straight pipe, tee, and gate valve models. Tees are placed at each branch junction. Straight pipe connects tees, valves and components. Valves are included on each branch to regulate flow rates throughout the system.

To minimize the complexity involved in adding reducers and expanders throughout the system, and to keep the system size within the computer memory constraints of the Silverlight S3D application, all pipe diameters are set to 300 mm. To enhance the accuracy of the model, the piping system component weights were calculated outside of S3D using the analysis results.

The piping system weight was calculated as follows:

1. The system was configured with all loads operating at their maximum power setting.
2. Valves were set to provide flow to each component to cool the component to adequate temperature.
3. The mass flow rate through each branch was calculated via analysis.
4. A branch pipe and valve diameter was evaluated such that the analysis mass flow rate achieved a flow velocity of approximately 2.7 m/s.
5. The evaluated diameter was rounded up to the next larger standard pipe size.
6. Weight per unit length for pipes and valve weights for the standard-sized pipes and valves were imported into S3D, overwriting the standard 300mm-diameter weights.

Within S3D the total system weight was calculated using the imported component weights and the piping system routing lengths.

For the mission analyses, the system is configured with the port and starboard header cross-connect valves closed and the valves to the branches from the header to the loads connected such that each branch is fed from only one side. The valves at the loads are set such that all of the loads remained a similar temperature. The chillers were set to keep the header temperature at 6.7°C with a seawater inlet temperature of 29.4°C.

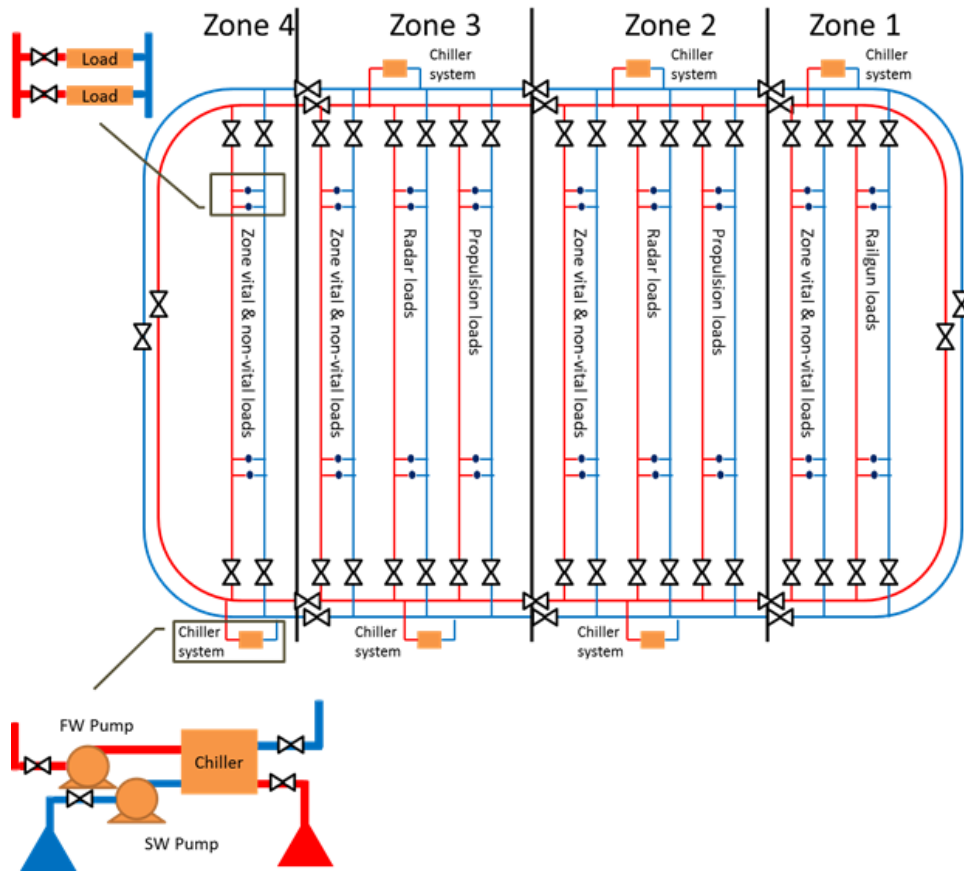

Figure 8. Baseline thermal management system.

The baseline cooling systems for all of the design variants except for the advanced materials design have the same layout and configuration for analysis as the baseline.

4.1.4 Gas Turbine Engine Specific Fuel Consumption

SFC is the mass of fuel required to produce a given amount of energy at a particular operating point (power level) and under specified operational conditions (e.g. elevation, temperature). Within S3D, specific fuel consumption is measured in kg/MJ. SFC reflects the efficiency of the engine to convert the energy in the fuel to useful work at the output shaft. Gas turbines are typically most efficient – operating with the lowest SFC – at their maximum rated power condition. SFC increases as temperature and elevation increase and as the engine output power decreases below the rated power; off-optimum operating conditions can result in significant increases in SFC and total fuel consumption.

Engine SFC values at maximum rated power and curves of SFC versus power level are typically presented at ISO conditions (59°F, sea level). The maximum rated power and SFC versus power curves were modified to reflect the “penalty” on maximum rated power and SFC for operation at

the 100°F Navy-Day condition. Published data on the impact of ambient temperature on the SFC of gas turbines was used to generate notional curves of SFC versus power level for the LM2500+G4 and LM500 engines. Figure 9 shows the impact of temperature for a range of fuel/air ratios; note the essentially linear increase in SFC with inlet temperature [Rahman et al., 2011]. Table 8 shows the modified power levels and corresponding SFC values used in the mission simulations.

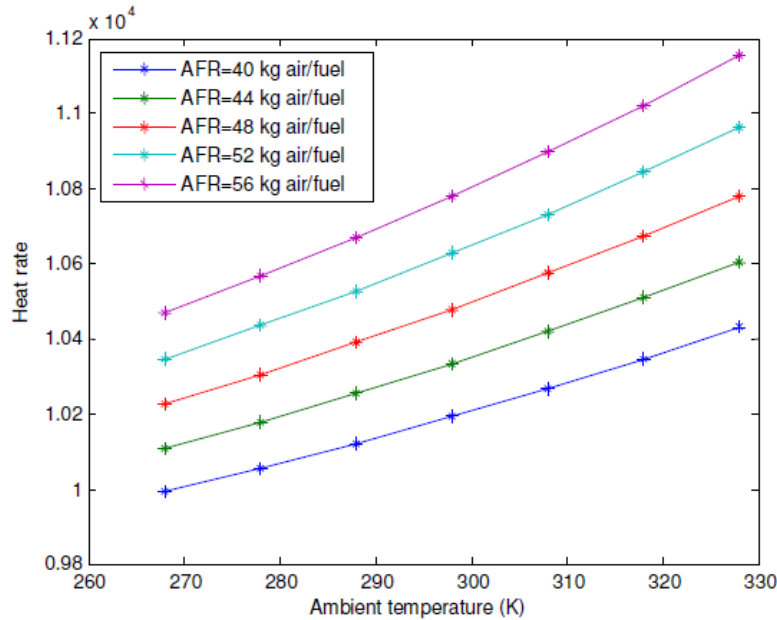

Figure 9. Effect of ambient temperature and air to fuel ratio on heat rate [Rahman et al. 2011].

Table 8. Assumed power level and specific fuel consumption for gas turbine generator sets used in the study.

	Power Level [MW]	Specific Fuel Consumption [kg/MJ]
LM2500	2000	0.268
	8000	0.155
	20000	0.072
	29000	0.062
LM500	300	0.186
	900	0.124
	1500	0.093
	2250	0.082
	3700	0.077

4.1.5 Equipment Arrangement / 3D Visualization

Equipment arrangements were accomplished using the 3D visualization capability within the naval architecture workspace. Figure C.3 in Appendix C shows the arrangement of the baseline design. Payload and major equipment locations were determined from the ASSET run; remaining smaller equipment items were located logically, developing from this baseline positioning.

4.2 Design Variant 1: High Speed Power Generation

This design variant was explored to assess the ability of S3D to include the effects of a known technology improvement, in which a known machine is directly substituted for the comparable component in the Baseline Design. The Navy is currently evaluating the use of high-speed rotating electric machines to reduce the size and weight of these power system components. DC distribution systems are particularly well suited for high speed power generation in that the high frequency output of the generator is immediately rectified. This eliminates the need for synchronization of multiple generators and simplifies the integration of machines with different operating speeds and frequencies. DC distribution systems also allow the gas turbines to operate at their optimum speed for a given load, improving the overall efficiency of prime power generation at less than peak load. There is a relatively minor increase in generator losses due to operation at higher rotational speeds and electrical frequencies; since data for the efficiency impact on the notional high speed generators was not available, the notional power level versus efficiency curve created for the baseline was modified to reduce the generator efficiency by 0.5%.

Table 9 displays a comparison of the sizes and weights of the two Gas Turbine Generator (GTG) models used in this ship design. Changing the generators in the three primary LM2500+G4 GTGs and three secondary LM500 GTGs from standard to high-speed generators creates a total direct weight savings of approximately 208 metric tons. Moreover, the cascading effects of this weight change are evidenced in major reductions in foundation weights and minor reductions in many auxiliary systems, and the total impact of this change is an increase of 304 metric tons of fuel, which increases range from 50 to over 1900 nautical miles, as determined by modifying the generator weights in ASSET. The fuel increase has its own cascading effect of increased fuel storage and support equipment weight; this effect is fairly minor and is already included in the above calculations.

Table 9: Weights and dimensions of gas turbine generator sets.

	LM2500+G4		LM500	
	Standard	High-Speed	Standard	High-Speed
Length (m)	14.38	11.41	7.14	5.87
Width (m)	3.81	3.81	2.36	2.36
Height (m)	2.44	2.44	2.39	2.39

Weight (mt)	97.05	40.05	27.3	15.0
--------------------	-------	-------	------	------

4.3 Design Variant 2: Advanced Materials

This design variant was explored to assess the ability of S3D to measure the ship-wide impact of changes in specific components within an unchanged topology; specifically, the converter equipment was assumed to be made of an advanced material that allowed increased distribution voltage, reduced losses, higher material operating temperature and reduced size and weight.

There are several potential benefits from advanced power conversion technologies:

- **Reduced Power Conversion Weight and Volume:** the individual converters were assumed to take up less volume and have a lower weight for the same conversion power. The goal of this exercise is to show cascading effects of the changes beyond just size and weight of the converters.
- **Reduced Cable Plant:** a higher distribution voltage reduces current required for a given power level. The reduced copper weight is partially offset by increased insulation requirements but the net effect is a reduction in the cable plant weight.
- **Reduced Cooling Requirements:** the higher temperature capability allows direct fresh water cooling of the converters as opposed to chilled water; this reduces the required number of chillers and the complexity of the thermal management subsystem, but may show increases in piping weight due to the inclusion of a fresh water cooling system in addition to the chilled water system. In addition, the higher efficiency of the devices will require less cooling.

This methodology could be indicative of the effects of including advanced wide-bandgap (SiC, GaN) power conversion technologies, which offer the potential for significant reductions in the size and weight of the power conversion elements. However, the data available on the dimensions and weight of representative SiC or GaN power electronics equipment was conflicting. To avoid providing inaccurate data on specific technologies, we assumed a hypothetical “advanced material” converter series and re-parameterized the converters as indicated in Table 10. In addition, the efficiency of converters using advanced materials was set at 99% instead of the 98% used for Si technology converters.

Table 10. Multiplication factors for “advanced material” power electronics.

Property	Multiplication Factor
Length	0.7
Width	1.0
Height	1.0
Weight	0.85

To accomplish the Variant 2 design, the baseline ship design was cloned. The voltage ratings for the main bus cables, dc disconnects, and power converters were increased to 20kVdc and the

generator voltage was increased to 13.8 kVac. Cabling was resized for the new voltages using commercially available high voltage cables. The dc disconnect (no-load) and ac circuit breaker dimensions and weights were left unchanged.

The improved efficiency of the advanced material power converters reduces the total cooling load for the design. Additionally, the ability to operate at higher temperatures, where higher cooling and heated water differential – and corresponding higher heat transfer - occurs, makes the use of heat exchangers a viable cooling method. The cooling system for this design was designed to account for these factors. The system for this design contains a chilled water header system with the same layout as that for the baseline design, except that it has 2 fewer chillers, and two freshwater loops with heat exchangers for cooling are added. The freshwater loops cool many of the advanced material power converters which are able to operate at higher temperatures. The freshwater loops are cross connected to the chilled water system for redundancy.

For analyses the system was configured similar to the baseline configuration, with all cross connect valves closed, and loads receiving cooling water from branches off either the port or starboard sides.

4.4 Design Variant 3: Alternate Topology

This design variant was chosen to investigate the effect of changing the topology of the power distribution system. A new zonal topology was developed loosely based on a proposed MVDC architecture circulated by the U.S. Navy [Doerry 2016]. This zonal topology, depicted in Figure 10, uses cross-zone connections between ac load centers in adjacent zones to provide the required redundant power supply for mission loads and vital zonal loads and introduces several new component configurations and functionalities.

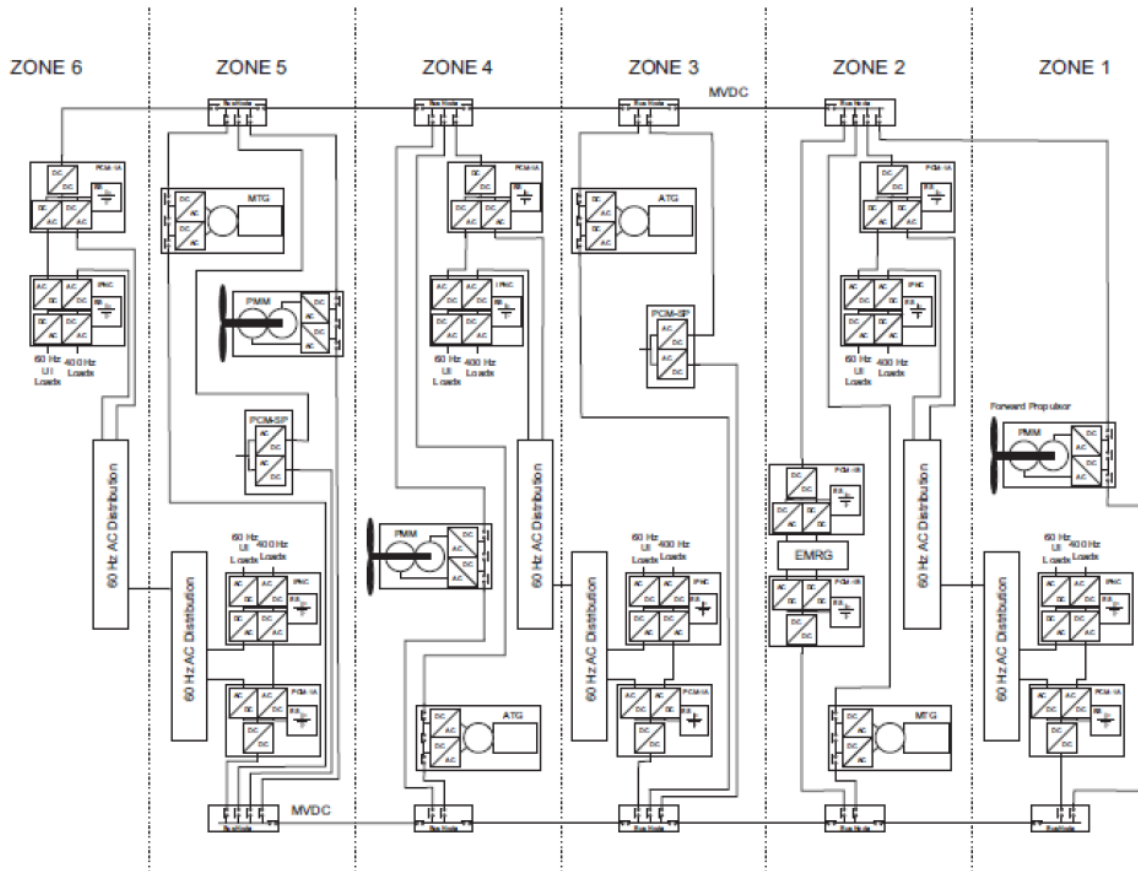

Figure 10. U.S. Navy Proposed MVDC Architecture [Doerry 2016].

Bus Nodes

Bus nodes (Figure 11) provide the interface disconnects between zones and the disconnects (or other dc circuit protection devices) between the high voltage main distribution bus and other major power system components. Primary bus node connections include the power generation modules, high power MVDC mission loads, propulsion loads, and in-zone power distribution hardware (e.g. PCM-1A). If necessary, a ground reference device can be included in the bus node or possibly integrated within the PCM-1A and/or Power Generation Modules. This study did not investigate grounding effects.

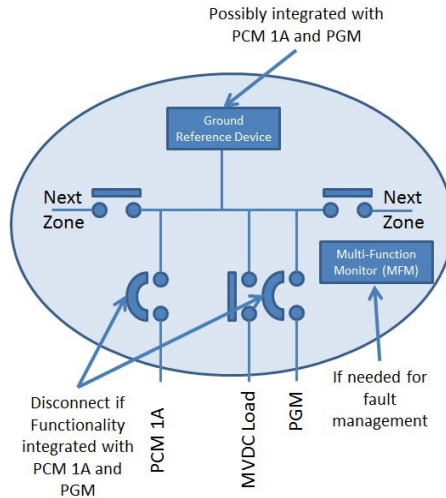

Figure 11. Bus Node functional block diagram.

PCM-1A

The functionality of Power Conversion Module 1A (PCM-1A) is shown in Figure 12. The PCM-1A is connected directly to the Bus Node, receiving power from the high voltage main distribution buses. Input modules provide step down conversion to the in-zone distribution voltage, in this case, an internal 1000 Vdc bus.

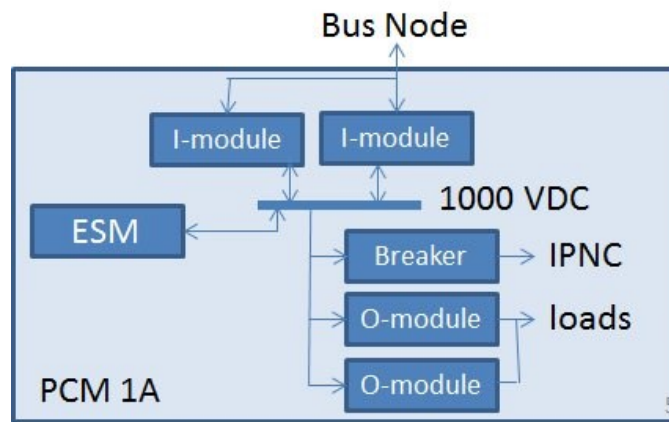

Figure 12. PCM-1A functional block diagram.

Output modules and/or circuit protection devices then provide interfaces to in-zone IPNC modules (see below) or to in-zone loads via an ac load center (ACLC).

Integrated Power Node Center (IPNC)

In the S3D architecture, the integrated power node centers (IPNC) receive 1000 Vdc from the PCM-1A modules and convert it to supply loads with special power needs including 400 Hz subsystems and variable speed drive motor loads. (Operation at the 1 kVdc input voltage will require an update of the applicable standard Mil-PRF-32272.) The IPNC may also include local

energy storage (~1 second) to allow the 450 Vac load centers to reconfigure in the event of a fault.

For this study, no weight was included for energy storage in the IPNC or PCM-1A modules since energy storage was not specifically modeled in the other variants. Including weight for energy storage in these modules would have improperly penalized the alternate topology variant.

AC Load Centers

The zonal distribution systems include multiple ac load centers (ACLC) to provide disconnect/circuit protection for in-zone ac loads. Interconnections between the ACLC's cross distribution system zonal boundaries, providing the required redundant power supply for in-zone mission and vital loads.

The proposed architecture has several component functionalities that were not originally supported in S3D equipment library, including the IPNC and PCM-1A modules which have multiple inputs and multiple outputs at different voltages and frequencies. Accurate representation of these functions required coding new component models.

4.5 Design Variant 4: Mechanical Electrical Hybrid

This design variant was developed to explore the impact of a hybrid mechanical/electrical power and propulsion system and to provide insight into the potential to backfit higher power electrical generation and distribution systems to support advanced electrical weapons and sensors on existing platforms. This notional design variant is based on the DDG-51 power configuration which uses four gas turbines mounted on two combining gearboxes for mechanical propulsion and three smaller GTG's for the ship service electrical distribution system. The Mechanical/Electrical Hybrid design variant retains the two main reduction gears (MRG) but replaces one of the LM2500 GTG's on each gearbox with a 10 MW motor/generator and the associated power electronics to provide a bi-directional interface to the ship electric power distribution system.

This design variant captures the efficiency of mechanical drive at high speed/power and also allows the ship to operate efficiently with electric propulsion at lower speed/power. A key design trade in this variant is the weight and volume of the gearboxes relative to the weight and volume of direct-drive propulsion motors and the associated power electronics. As noted previously, limiting the study to Distribution A data makes a quantitative comparison very challenging as weight and volume data for the MRG's was not found in public sources.

Another design feature to note in this design variant is the substitution of an LM2500+G4 high speed turbine generator set for one of the AG9140 ship service generator sets that is currently used in the DDG 51 ship design. The swept volume of the AG9140 uptake ducting effectively increases the length of the unit such that the overall volume (skid plus ducting) is comparable to that of the 30 MW high speed generator set. [Herbst et al 2013 ASNE Day]

In addition to the two 3,600 rpm gearbox-mounted motor/generators, this variant included other design features:

- High Speed Ship Service Generators: in this variant, we substituted updated 4.7 MW LM500 GTGS for two of the SSGTG's and a 30 MW LM2500/Vectra 40G GTG for the third generator set.
- Pulsed Alternator (PA) Based Pulsed Power System: in this variant, we modified the pulsed power supply for the EM Railgun by replacing the notional capacitor-based pulse forming network with an array of pulsed alternators. Each of the four PA's includes a 5 MW motor/generator and bi-directional power converter to interface with the ship's power distribution system.

This design variant presented several challenges to S3D, most notably the bi-directional nature of the electric machines and power converters connected to the main reduction gearboxes and the operation of the pulsed alternators. This affects primarily the Mission Analysis evaluations as in some segments the machines operate as generators and in other segments they operate as motors. These challenges are relatively straightforward to address but were beyond the scope of the current effort so the emission evaluations and comparisons with the other designs are not presented

5 Design Evaluations

In addition to the goal of exercising the S3D collaborative design tool on more complex designs with specific constraints and performance requirements, the project also allowed side-by-side comparisons of different design variants to evaluate the impact of advanced technologies. The design work in S3D was supplemented by corresponding analysis runs in ASSET, allowing the team to leverage the existing data and empirical algorithms for sizing of support structures and tankage that are not explicitly defined in S3D.

Full results and comparisons are available in the model. A subset of data is provided and discussed herein.

5.1 Weight

Weight within S3D is calculated as a summation of the weights of individual components. Total weight can be viewed in the S3D design dashboard, organized by equipment type or SWBS and filtered by discipline, SWBS, equipment type, etc.

Weights at the one-digit SWBS grouping for both ASSET and S3D are shown in Table 11. There are significant differences between the weights produced using ASSET and the S3D weights, mainly because many things estimated in ASSET are not addressed in S3D; for example, structural and foundation weights, water in the piping, and small tools. Further differences may be caused by SWBS categories in S3D not aligning perfectly with ASSET categories since a

single component in S3D has only one SWBS number assigned to it; further delineation of weights would require breaking components down into smaller constituent parts. For example, a gas turbine generator component in S3D may include lubricating oil, fuel oil, and foundation weights that fall into SWBS categories other than the core electrical power generation SWBS.

Table 11. Weights by SWBS group in ASSET and S3D.

SWBS Group	ASSET Weight (mt)	S3D Weight (mt)
100 Hull Structure	3,470	-
200 Propulsion Plant	1,370	320
300 Electric Plant	1,540	610
400 Command & Surveillance	400	160
500 Auxiliary Systems	880	330
600 Outfit and Furnishings	530	-
700 Armament	330	320
F00 Loads	700	20
TOTAL With Margins	9,220	1,748

Despite the differences between the overall ship weights estimated by ASSET and those estimated within S3D, interesting details of the ship designs can be investigated using the S3D data. Table 12 shows a comparison by three-digit SWBS group of weights in each variant of this study; total weight by category and the change in weight from the baseline are shown. Some SWBS groups remain constant from one variant to another, so those weights are not included in Table 12.

In the High-Speed Generator Variant, the only change was a swap of the regular gas-turbine generators for high-speed generators; therefore the only weight group that changed was SWBS311, which covers power generation and conversion equipment.

In the Advanced Materials Variant, weight group 311 changed as expected because all of the power conversion equipment was lighter. There is also a change in the propulsion weight group, SWBS 235, because the propulsion motor drives are lighter. The advanced materials enabled a higher voltage distribution bus, which caused the cabling to be lighter as shown in weight group 321. Finally, all the conversion equipment was allowed to operate at a higher temperature, resulting in lower weights in the chiller equipment and piping SWBS groups.

In the Alternative Topology Variant, a reduction in the number of converters and switchgear for each zone resulted in a reduction in the overall weight for power generation and conversion equipment, even though the remaining converters had to be increased in size to accommodate the increased per-converter power demands. There was also a small reduction in weight for chilled water piping because the removal of some liquid-cooled converters also removed the piping routed to them. Interestingly, there was an increase in the cabling weight because the cross-connect cable from one zone to the next was at the low voltage of the in-zone cabling and was therefore substantial; the two cross-connect cables weighed a total of 43 mt. Since the cross-

connect cables operate at 450Vac and are required to carry many megawatts of power, they are comprised of many individual cables – 16 cables in the forward bundle and 11 cables in the aft bundle, for a weight per unit length of 135 kg/m forward and 93 kg/m aft. The cables are also of significant length; 70 m forward and 52 m aft.

Table 12. Weights in metric tons by SWBS group for each variant.

SWBS Group		Total Weight By Category (mt)				Change from Baseline (mt)		
		Baseline	High-Speed Generator	Advanced Materials	Alternate Topology	High-Speed Generator	Advanced Materials	Alternate Topology
235	Propulsion	24.7	24.7	21.0	24.7	-	3.7	-
311	Power gen. & conversion	510.4	302.7	489.8	473.9	207.7	20.6	36.6
321	Cabling	71.4	68.8	51.9	109.2	-	19.5	(37.8)
324	Switchgear	24.6	24.6	24.6	14.9	-	-	9.8
514	Chilled water equipment	245.5	245.5	168.7	245.5	-	76.9	-
532	Piping	76.8	76.8	56.4	74.3	-	20.5	2.5
TOTAL						207.7	141.2	11.0

5.2 Volume

Similar to weight, volume can be analyzed in S3D by equipment type or SWBS group. Volume is a summation of the volume of individual components, calculated as the component’s axis-aligned bounding box volume. Note that the differences seen in the volume groupings are similar to those seen in the weight analysis above, for the same reasons. A summary is presented in Table 13.

Table 13. Volume in cubic meters.

SWBS Group	Baseline	High-Speed Generator	Advanced Materials	Alternate Topology
235 Propulsion	90	90	63	90
311 Power generation and conversion	1,429	1,060	1,234	1,225
321 Cabling	248	248	231	266
324 Switchgear	64	64	64	42
514 Chilled water equipment	311	311	236	311
532 Piping	343	343	363	314

5.3 Number of Components

The number of components for a specific design or for subsets of the design such as equipment type or SWBS number may be used as an indicator of complexity of the design as long as the designs are at an equivalent level of fidelity. The number of components in each SWBS category for all components modeled in all the S3D variants is shown in Table 14. Two takeaways: first, the number of components in the alternate topology variant is much lower than the other variants, reflecting the much reduced complexity of the design. Second, the number of components in the piping SWBS is much higher than any other category; this is because the modeling methodology in the piping designer requires more components to achieve the same level of detail as in the other design tools.

Table 14. Number of components.

SWBS Group	Baseline	High-Speed Generator	Advanced Materials	Alternate Topology
100 Uptakes	12	12	12	12
200 Propulsion Motor	2	2	2	2
235 Propulsion Motor Drive	4	4	4	4
243 Shafts	2	2	2	2
245 Propellers	2	2	2	2
311 Converters	30	30	30	22
321 Cabling	90	90	86	67
324 Switchgear	62	62	62	39
410 Integrated Topside	4	4	4	4
456 Radar	8	8	8	8
461 Sonar	3	3	3	3
514 Chiller Equipment	49	49	46	49
532 Chilled Water Piping	566	566	567	553
541 Fuel Pipe	8	8	8	8
586 RAST	2	2	2	2
600 Vital/Nonvital Loads	10	10	10	10
711 Guns	15	15	15	15
721 Missiles	2	2	2	2
F23 Helicopters	2	2	2	2
TOTAL	873	873	867	806

5.4 Power Demand, Cooling Required and Fuel Consumption

In addition to the “static” comparisons of fixed parameters presented above, S3D can also evaluate designs based on quasi-static mission simulations (see Section 2.2) to capture the effects of time-dependent performance parameters such as fuel consumption and range. A mission is defined by a series of mission segments; each mission segment is defined by duration or distance

and a specific system configuration describing the ship speed, active loads, switch settings and power generation alignments. The mission analyzer calculates total fuel consumption based on the duration of the mission segment, the mechanical power output required from the gas turbines to drive the generators, and the specific fuel consumption (SFC) characteristics of the engine.

For the purposes of this study, a three-phase mission was created consisting of a peacetime cruise segment, a sprint to station, and on-station operations. The peacetime cruise segment operated the ship at 15 knots in cruise condition with all weapons off, radar at reduced power, vital loads at medium power and non-vital loads at maximum power. The sprint to station segment operated the ship at a high speed of 28 knots in surge condition with RADAR and InTop at full power and weapons at reduced power. The battle condition segment provided full power to all weapons, full power to vital loads and medium power to non-vital loads, with remaining power available for battle speed. Typically during battle condition, all generators are online despite the reduced efficiency to maximize redundancy and responsiveness of the plant. Because of the extended 7-day duration of this mission segment, fuel consumption would be unrealistic with all generators online. For the final mission simulation runs only two LM2500's were online, consistent with the other mission segments. The status is summarized in Table 15.

Table 15. Mission segment alignment summary.

Mission Segment	Speed (kts)	Duration (days)	Weapons	Sensors	Vital Loads	Non-vital Loads
Peacetime Cruise	15	90	Off	Med	Med	High
Sprint to Station	32	1	Med	High (select loads)	High	Med
Battle	8	7	High	High	High	Med

As a comparison, excerpts from the design dashboard are included for each mission segment in Figure 13, showing electrical power demand by one-digit SWBS group for the baseline design. Note the change in relative percentage used for each: peacetime cruise is fairly equally spread between functions, sprint to station is dominated by propulsion, and on-station battle is dominated by sensors.

The results of the mission analysis are presented in Table 16. Although the total fuel consumption is very close between the variants, less than 0.5% difference overall, the differences bring out interesting features of the designs, as described below:

High-Speed Generator: The only difference between the baseline and the high-speed generator variant is the change in generators; all other equipment and the layout are the same. The slightly lower efficiency of the generators should be reflected in a higher electrical demand, a higher liquid cooling requirement, and a higher fuel consumption. The decreased generator efficiency was 0.5%; however, the changes in electrical demand, liquid cooling and fuel consumption will not be exactly 0.5% because there is also an increase in power to the chillers and pumps, which is slightly counteracted by the gas turbine operating at a somewhat improved SFC due to the increased power demand.

Alternate Materials: The differences between the baseline and the alternate materials variant include improved efficiency of all converters and reduced power for cooling equipment. This is reflected in the lower fuel consumption, lower electrical load, and lower liquid cooling requirement.

Alternate Topology: The alternate topology arrangement operates at the same efficiency for the converters and with the same cooling paradigm as the baseline; however, there are differences in the number of converters that power flows through in this arrangement. Although the S3D converter models allow efficiency to vary with load, in this simulation, all converters are set to a level 98% efficiency regardless of power flow. In the alternate topology arrangement, all power to in-zone dc loads flows through two converters between the main bus and the load (the PCM1A and the IPNC) instead of just one converter in the other topologies (the in-zone dc-dc converter). Therefore, all in-zone dc loads draw more power from the generators in the alternate topology variant than in the baseline and the alternate topology should operate at a slightly lower overall efficiency. This difference will be more noticeable when the total electrical load is more heavily weighted by in-zone dc loads; propulsion, ac loads, and major mission loads should have the same efficiency as the other topologies in this study.

Mechanical Power: The mechanical power demand is identical across all four variants analyzed; this is as expected because the speed and the power train are identical across all four variants.

It should be noted that fuel consumption is significantly affected by the relative loading on generators, due to the shape of the specific fuel consumption curves. In general, two equally-loaded gas-turbine generators will consume much less fuel than one heavily-loaded generator

Table 16. Mission results.

	Mission Segment	Baseline	High-Speed Generator	Advanced Materials	Alternate Topology
Fuel Consumed During Segment (kl)	Peacetime Cruise	23,164	23,171	23,095	23,264
	Sprint to Station	332	334	329	338
	On Station	1,808	1,809	1,804	1,810
	TOTAL	25,304	25,314	25,228	25,412
Electrical Power Demand (MW)	Peacetime Cruise	22.985	23.012	21.587	24.047
	Sprint to Station	43.488	43.689	42.611	44.525
	On Station	23.727	23.756	22.842	24.422
Mechanical Power Demand (MW)	Peacetime Cruise	3.442	3.442	3.442	3.442
	Sprint to Station	29.074	29.074	29.074	29.074
	On Station	0.544	0.544	0.544	0.544
Liquid Cooling Required (MW)	Peacetime Cruise	12.262	12.354	11.764	12.410
	Sprint to Station	9.280	9.505	8.471	9.398
	On Station	12.610	12.711	12.107	12.830

and one lightly-loaded generator, since a gas turbine at light load is extremely inefficient. This must be recognized during the comparison of mission scenarios across ships to ensure the differences seen in fuel consumption are due to the installed equipment and not to the operational choices.

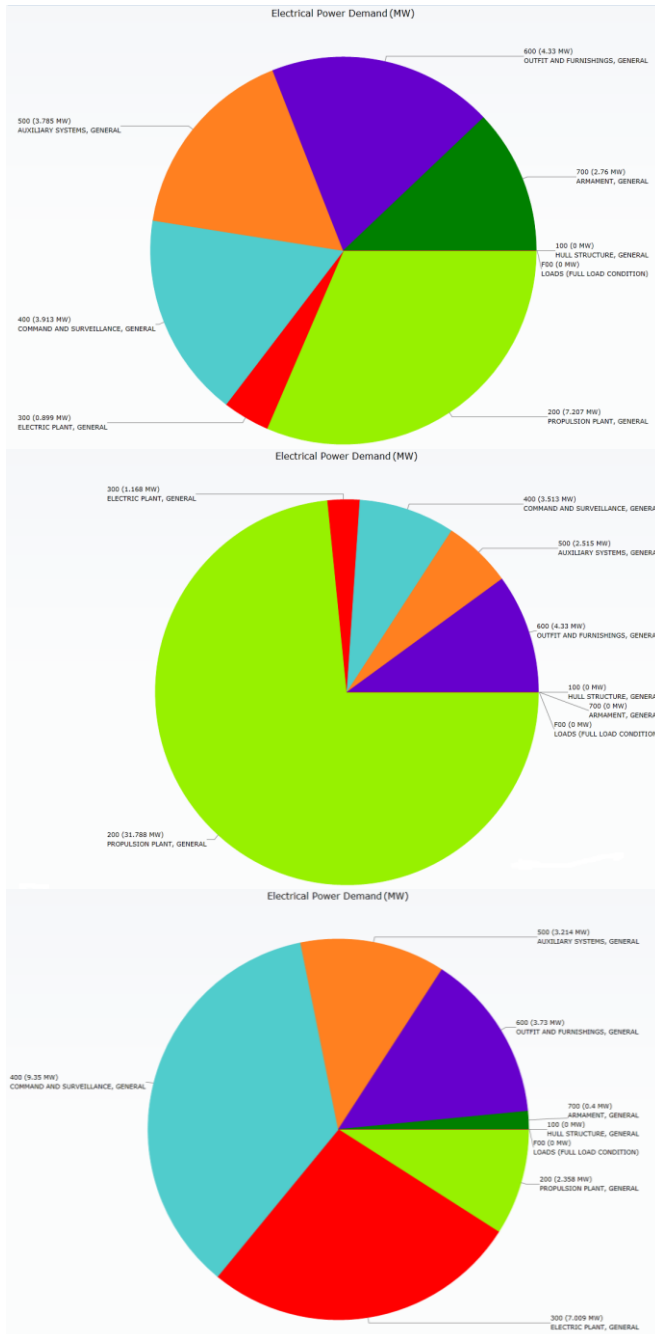

**Electrical Power Demand
by SWBS Group**

- 200 Propulsion – Yellow
- 300 Electric Plant – Red
- 400 Command and Surveillance – Blue
- 500 Auxiliary Systems – Orange
- 600 Vital/Non-vital Loads – Purple
- 700 Armament – Green

Figure 13. Electrical power demand for the baseline design during peacetime cruise (top), sprint to station (center) and on-station battle (bottom), by one-digit SWBS group.

A second analysis was accomplished to assess the impact of single-generator operations. The peacetime cruise segment was duplicated for all four designs, operating with a single generator online; the resultant power fuel consumed was approximately 60% of the fuel consumed under two-generator operations. See Figure 14.

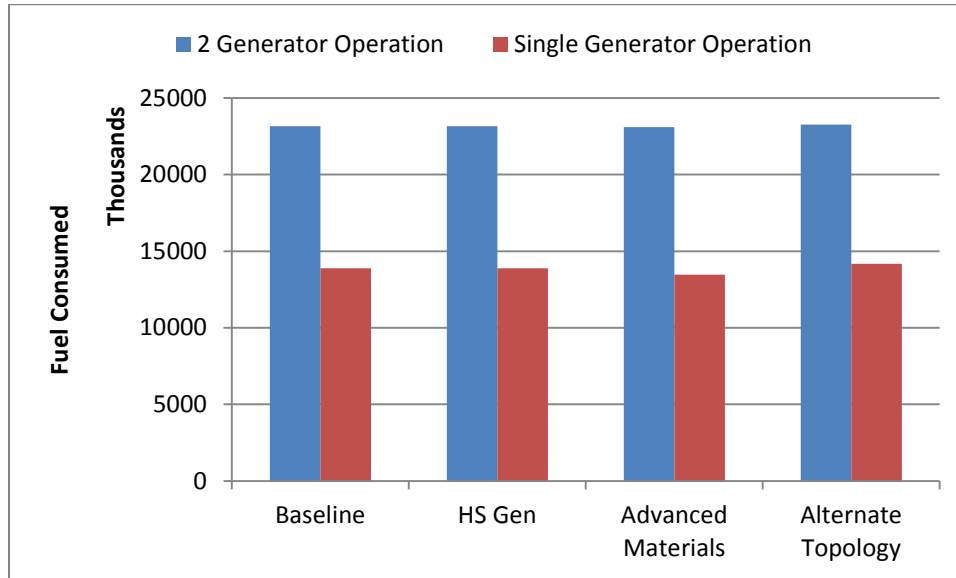

Figure 14. Fuel consumed in normal (two-generator) and high-efficiency (single-generator) alignments.

5.5 Range

The range a design can attain in S3D involves running the ship model, set in a fuel efficient configuration, through a long duration mission. The mission analyzer evaluates the multidisciplinary steady state power usage values and the corresponding fuel consumption rate, and calculates the distance traveled using all of the fuel in the tanks.

The premise of this study is that total ship displacement is held constant at 10,000 mt. Any weight savings realized through advanced concepts were replaced with fuel. The analysis conducted within S3D calculates weight savings of the actual equipment modeled; however, there are also other associated weight savings, e.g. foundations, ship structure, and operating fluids. To estimate these additional savings, the S3D equipment weight changes were input into ASSET using the Payload and Adjustments table in order to use the ASSET algorithms to calculate the decreases in foundations and other support and the increases in structural weight for the additional fuel load. Thus, an equipment savings in S3D resulted in a greater than equivalent increase in fuel weight. These values are displayed in Table 17.

The mission analyzer tool was then employed to calculate range. For this example, the designs were analyzed in the peacetime cruise battle condition with the speed set to 20 kts and the fuel flag set to note when the ship runs out of fuel. The fuel tanks were filled with the amount of fuel available excluding the tailpipe allowance, as calculated by ASSET.

Table 17. Fuel load for range calculation.

	Baseline	High-Speed Generator	Advanced Materials	Alternate Topology
Equipment Weight Saved (mt)	--	207.7	141.2	11.0
Fuel Weight Added (mt)	--	303.5	182.7	25.7
Fuel Weight (mt)	23.9	327.4	206.6	49.6
Fuel Volume (l)	28,092	384,814	242,830	58,298

The ship speed was set such that the combined speed/power curve and propulsion efficiency produce the highest combined efficiency. For the designs studied this occurs near 20 kts. The total electrical load including propulsion for the designs is near 29MW, which is the rated power of one LM2500. Each design was configured with identical power generation (one LM2500 online), and identical hotel and mission load settings. Cooling systems were configured identically for all but the Advanced Materials design. The Advanced Materials design’s cooling system is different than the other three designs, but was configured to be as similar as possible to the others.

The range and steady state power demand results for the range mission using these fuel tank levels and ship configurations are shown in Table 18.

Table 18. Range and steady state power demand results for range mission.

Design	Range (km)	Fuel Consumption Rate	Electric Demand (MW)	Mechanical Demand (MW)	Cooling Required (MW)
Baseline	140	1.81	28.447	9.698	9.778
High-Speed Generator	1913	1.81	28.496	9.698	9.923
Advanced Materials	1240	1.77	27.508	9.698	9.17
Alternate Topology	286	1.84	29.25	9.698	9.951

5.6 Uncertainty

A small test was run to introduce the study of uncertainty. The positions of each piece of equipment in the baseline were randomly changed within one meter in the x, y and z directions respectively; that is, a different random number between -1.0 and 1.0 was added to each of the x, y and z locations for every piece of equipment modeled. The distributed systems were refreshed, and weights compared. Results for two such tests are shown in Table 19. The total change due to this uncertainty experiment was in the neighborhood of 2-3 metric tons. The total weight changes due to the planned ship variant designs were in the neighborhood of 100-200 metric tons for the high-speed generator and the advanced materials designs, so the uncertainty is small in comparison to the design change. However, the total weight change due to the planned alternate topology variant was 11 metric tons, and the changes in the individual weight groups were in the

10-30 metric ton range, so the conclusions for the alternate topology variant may be significantly impacted by uncertainty.

Table 19. Results for test of uncertainty.

SWBS	Group	Run 1			Run 2		
		Weight Change (mt)	Percent Weight Change	Maximum Single Weight Change (kg)	Weight Change (mt)	Percent Weight Change	Maximum Single Weight Change (kg)
321	Cabling	1.25	2.6%	0.366	1.26	2.59%	0.127
514	Chilled Water Equipment	0.13	9.4%	0.077	0.37	27.47%	0.178
532	Piping	1.68	2.5%	0.108	0.89	1.34%	0.288
541	Fuel	0.007	15.4%	0.002	0.0005	1.08%	0.001
	TOTAL	3.06	2.6%		2.51	2.16%	

6 S3D Advances and Recommendations

Throughout the project, the capabilities of S3D were exercised and stretched. Numerous recommendations for upgrades were immediately implemented, while some recommendations are retained for future research. A summary of these changes is provided below.

6.1 Equipment Models

In order to support the development of design variants, several new models were required and subsequently developed. The new models are the AC Load Center (ACLC), IPNC, PCM-1A, Twelve-phase AC Motor, Dual-Wound Generator, and the Split Gearbox.

In order to properly compare and contrast the design variants in the context of a mission, additional modifications to the solvers and mission analysis tool were required. In order for the mission analysis tool to produce results, all of the discipline-specific schematics are co-simulated until a point of convergence is reached and a consistent operating point for the alignment is established across all disciplines. Changes to the mission execution were required in order to ensure that the simulation results across all disciplines converged to this self-consistent solution. In addition, the simulation models were modified in order to properly account for time-dependent states such as energy storage, fuel, etc., to ensure that models with representations that cross discipline boundaries provide the necessary information to ensure convergence, and to enable certain models to raise simulation events that can be used by the mission analysis tool, such as equipment operating out of bounds, or fuel is depleted.

In some situations, it was necessary for the simulation model to be aware of the context in which it was being executed. The behavior of certain models needed to be modified depending on whether the analysis was being performed in the design tool or in the context of a mission. For example, while performing an analysis in the design tool it is not possible to run out of fuel or

fully charge a capacitor, since the analysis occurs at an instantaneous point in time. The models that required this specialized behavior were the Electrical Energy Storage, Capacitor, Mechanical Energy Storage, and the Storage Tank.

In order to determine whether the simulation converges across disciplines, models with representations in multiple disciplines must ensure that their simulation results are consistent across disciplines. For example, if the electrical motor is supplying a certain amount of mechanical power in the mechanical discipline, it must be supplied with a corresponding amount of electrical power given its efficiency at that operating point, and it must dissipate a certain amount of heat in the thermal discipline. Models which required changes to provide the mission analyzer with convergence information were the AC motor, DC Motor, Generator, Gensets, Turbines, Pumps, Water Chillers, Fans, and Air Handlers, as well as all loads that dissipate heat.

The introduction of simulation events and the model behavior related to simulation events was required in order to evaluate certain aspects of a ship design. For instance, if the user would like to determine the range of a vessel given a particular operating state, the mission analysis tool must be made aware of when the fuel in the tanks will be completely expended. This requires the introduction of a simulation event that can be raised by the fuel tank when such a condition occurs. The analysis tool needed to be modified in order to ensure that it could receive such events and be able to properly process them. In this case, the mission analysis tool halts the simulation and determines the distance the ship traveled. In another situation, the user might be trying to determine what the yearly fuel consumption of a ship would be, given the time the ship spends in various operating states. In this case, the event the fuel tank raises when the fuel is fully expended is ignored by the mission analysis tool, and the tank is automatically refueled. The mission definition and analysis tools were modified to add this capability. In addition, all simulation models were extended to support the raising of model specific events.

6.2 Process

Another goal of the ship design project was to exercise and explore the impact of S3D's current and emerging capabilities on the overall ship design process. In a typical ship design, the design/analysis work proceeds sequentially through various disciplines in the conventional design spiral. The ultimate objective of S3D is to allow designers in different locations to work concurrently in multiple disciplines. Although there are, by necessity, some tasks which must be performed before others, S3D enables the design to proceed concurrently through multiple design disciplines, accelerating the overall design process.

For this exercise, the hull displacement, objective distribution voltage and installed power were all specified. The S3D design exercise began with definition of requirements and mission loads and selection of the baseline architecture. The process enabled concurrent individual work in each discipline and used frequent group discussions to identify and resolve technical questions.

A baseline ship was constructed in ASSET, and the hullform, superstructure, and bulkhead and deck locations were transferred to S3D, along with the locations of the major equipment items. In addition, all loads that were estimated by ASSET but not specifically intended to be modeled in S3D were lumped by zone into vital and non-vital aggregated electrical loads with an appropriate efficiency to simulate aggregated thermal loads.

Next, the electrical and mechanical disciplines were used to populate the four zones of the distribution system and define the electrical and physical interconnections between the various system elements. The exercise demonstrated the ability for two designers to easily coordinate concurrent work within a single discipline; this enables further acceleration of the design process through increased resources.

Discipline-specific simulations were run to size system components and ensure that critical mission and system loads were supplied from the required two sources. As the electrical and mechanical schematics were constructed, the selected equipment was reflected into the Thermal/Fluids discipline and the designer began to assemble the cooling systems for the ship.

Simultaneously, the 3-D model in the Naval Architecture tool was used to place system components within the hull as they were defined within the other disciplines.

Refinement of the schematics continued until successful simulations could be executed in each discipline.

Once the electrical and mechanical systems were defined, more realistic representations of the electrical (cables) and physical (piping) interconnections between the system elements were implemented. One notable element of this process include semi-automated sizing of the cables. This semi-automated sizing of the cables was needed to provide a more realistic cable representation than is currently supported within S3D. The first step in the process involved the cables being sized automatically using the Cable Calculator within S3D [Card et al, 2015]. However, as will be discussed in Section 6.3, there are limitations due to the need for optimization and to reflect the total current that the cable should be able to conduct. Therefore, for the next step, the cables were exported from S3D and then manually tweaked to reflect the desired optimization and maximum loading conditions. Once the necessary changes were made, the final step of re-importing the updated cable information back into the S3D model provided a more accurate picture of the cables for the early stage design. Similarly, piping weights were externally tweaked to improve accuracy.

Refinements to the Design Dashboard to facilitate de-bugging and interpretation of simulation results were also accomplished.

6.3 Recommendations

The currently existing design spaces provide arrangement, connection and load-flow-level simulation of the systems. The design spaces all function well and the integration between the design spaces is seamless. The S3D tool provides significant new capability to the navy design

community, and there are many areas where improvement would make the tool even better. As the tools were exercised, the following specific recommendations for improvement were noted. Some of these items are included in the proposed work for the upcoming ESRDC contract.

6.3.1 Electrical Designer: Cable Calculator

It was determined during this exercise that the cable sizing should be based upon a different algorithm than that which exists inside S3D. Presently, the S3D tool provides the cable calculator algorithm with an electrical current value for sizing the cable. The current value that is provided is the maximum current that the given cable has seen during numerous scenarios within the electric design tool. However, as was shown in this exercise, running numerous scenarios for many different ship designs is time consuming and error prone, in that the worst case scenario may not have been simulated by the electrical designer. This resulted in the cable not always being sized properly to meet the load requirements, even with a growth factor allowed by the cable calculator. It is proposed to develop a revised algorithm for sizing the cable based upon attached load requirements, voltage drop considerations, and future growth. Another issue that was discovered during the exercise was that there needs to be more clarification for attributes between a “cable” versus a “bundle of cables” necessary to meet the load.

6.3.2 Piping Designer

Automatic sizing of piping is needed for rapid design and evaluation of piping systems. Existing equipment items have maximum cooling requirements based on their rated power and efficiency. The equipment modeler can define flow rate and pressure drop across the equipment if the naval architect has placed the unit in the ship and the cooling system designer has the header system designed. Given this initial information, there could be an automated piping routing tool that places and sizes piping and valves between the header and the loads using guidelines. There has been preliminary work in this area within ESRDC, see, e.g., [Babae et al., 2015].

6.3.3 Mechanical Designer

Use of the Mechanical Designer was somewhat limited in this exercise because of the focus on the electrical and thermal design of the MVDC Integrated Power System. Although not fully completed, the Mechanical/Electrical Hybrid design presented the most serious challenge to the design workspace; some lessons learned from the M/E Hybrid design exercise are presented below.

S3D does not currently support the concept of multi-function machines, components that can perform differently based on the plant alignment and operational conditions. For example, the M/E Hybrid design includes two electric machines mounted on the Main Reduction Gearboxes which can operate either as motors or generators. Not only are the machines operating differently, the interface to the power system is through bi-directional power converters. The

electric machines used to motor the pulsed alternators in the M/E Hybrid design can also perform as a generator and provide power back to the distribution bus.

Although this issue is more closely linked to the implementation of time-domain simulation capability in S3D, it currently affects the design evaluations done in the Mission Analyzer. Discrete ship designs and mission configurations must be generated for each operational state of the multi-function component and the results assembled from multiple simulation runs; this was a major issue that prevented full evaluation of the M/E Hybrid design.

6.3.4 HVAC Designer

Since the HVAC Designer was not completely available for use at the beginning of the project, it was not employed in this analysis. Initial use has indicated that the design tool may provide better analysis if implemented in a three-dimensional simulation at the compartment level. Work accomplished in [Chioccio et al., 2013] may be applicable to this effort. Development of tools to support the design of gas turbine intakes and uptakes is also underway.

6.3.5 Naval Architecture Designer

The naval architecture designer has many features that enable the placement and viewing of equipment, including such things as “fall to deck,” “quickhide” and viewing equipment by deck. During the course of this study, enhancements to these capabilities were included. For example, code to toggle on and off the routing of distribution components around installed components, and code to filter the viewing of equipment by deck were added.

Two specific further enhancements would be very useful. First, the ability to detect and flag collisions between equipment and other equipment, and between equipment and structures such as hull, decks and bulkheads, would assist in the arrangement of equipment. Second, the ability to hide and view subsets of equipment, such as by equipment type or SWBS, would facilitate the arrangements and error-checking procedure. Initial work in each of these areas is already underway.

6.3.6 Mission Module and Controls

The current Mission Module requires manual system configuration for each design. Prior to running a mission analysis, the thermal, mechanical, and electrical systems must each be configured for each mission segment. This manual system configuration process is problematic for two important reasons:

1. It is labor intensive, and potentially prone to error. Each configuration may require the setting of operating states for dozens or hundreds of components. Considering that there are multiple systems that must be configured in each mission segment and multiple mission segments, the user(s) may need to manually set thousands of component operating states.

2. If one wants to make informed decisions from comparison of two or more designs based on the mission results, the analysis must have each design's systems configured such that it presents its best behavior for each mission segment, so that the designs are compared fairly.

Automated optimized system configuration (i.e. high-level controls) are required to reduce the time to prepare to run a mission, reduce the risk of user error, and to ensure that designs are fairly evaluated. System controls are also required to permit the ship to adapt to events that occur within a mission segment (e.g. respond to a tripped breaker.)

At present, incorporating controls into S3D is an open topic. The successful control system must contain a set of functionalities and strategies sufficient to satisfy mission requirements at the time scales for which the analysis is performed.

6.3.7 Data Availability, Scalable Models, Verification and Validation

One superb feature of S3D is the ability to draw components from the equipment library and use them directly in designs. When a specific component at the specific desired design point is not available in the library, a scalable model or a notional model can be used.

The use of a scalable model of a component type is preferable to the use of a notional model because the scalable models include physics-based algorithms for sizing of components based on the use case. However, significant research is required to produce a viable scalable model, and the algorithms underlying scalable models must be revisited over time to ensure that advances in the state-of-the-art are included. Currently, scalable models of permanent-magnet rotating machines are available within S3D, and additional models are under development within ESRDC; see, e.g., [Sudhoff, 2015].

Notional models are simultaneously a boon and a liability; since any property associated with a notional component can be changed at will, the notional models provide great flexibility to model a wide range of existing and postulated equipment. However, this flexibility enables the creation of physically impossible equipment either by design or by accident. For example, the maximum power of a converter can be increased tenfold with no change to the dimensions or weight. The exporting feature of S3D enables checking for such anomalies.

One significant difficulty in this project was obtaining reliable data on the equipment that was desired for the systems designed. Expanding the equipment library with equipment-specific models that have been verified and validated by subject matter experts will make S3D a more valuable tool to the Navy. In addition, when forming a design team to explore new concepts, it is necessary to include experts in the areas of exploration in that design team.

6.3.8 Aggregated Loads and Assemblies

At the very early stages of design when the level of detail is low, it is desirable to use representative loads and components that amalgamate the functionality and impact of many smaller components. The current design exercise relied on ASSET models to capture the weight and volume of the “balance-of-plant” elements of the ship power system; these elements were included as lumped vital and non-vital zonal loads designed to represent the power and cooling demands of a wide range of small loads that were not individually modeled, e.g. lighting, hotel loads, and firefighting equipment. Support equipment for weapons and sensors were also represented as single components although some represent multiple functions in multiple cabinets and enclosures. In addition, many components that are individually modeled in S3D actually comprise assemblies of many small components, e.g. a gas turbine generator includes the gas turbine, shaft, generator, lube oil pumps and piping, fuel oil service, fans, enclosure, and more.

As the design progresses, these aggregated loads and assemblies should be modeled more explicitly in the S3D designs to accurately reflect how the equipment can actually be packaged most effectively and to analyze performance in more detail. Obviously, there must be a balance between complexity and accuracy. When breaking an aggregated item into constituent parts, every constituent part may not be individually modeled. The process of determining how much weight, volume, power, cooling, etc., that must be included in the amalgamated loads and how much must be removed when portions of the amalgamated load are modeled is a challenging question that requires more investigation.

A related issue is the need for flagging of additional equipment that is necessitated by the inclusion of a component. Gas turbine generators (GTG's) are a good example; in addition to the shock mounted skid containing the engine enclosure and generator, there are also starting, fuel, and lubrication skids associated with the primary GTG component. Each of these subsystems must have the required redundancy to ensure safe shutdown of the equipment in the event of the loss of the primary and secondary systems. (The Main Gas Turbine lubrication skid requires two electric-motor driven pumps and one compressed air motor driven pump along with the associated reservoir, valves, filters, etc.) When the electrical designer places a gas turbine generator set in the electrical schematic, pre-defined starting, fuel and lubrication skid components could be exported to the Mechanical and Naval Architect workspaces. It will likely still be advantageous to aggregate discrete electric loads in the support equipment into lumped vital and non-vital loads to minimize the complexity of the electrical schematic and simulations but these components should be accounted for in the mechanical and Naval Architecture designs.

6.3.9 Margins, Allowances, Uncertainty and Risk

With the exception of the cable sizing algorithms, the ship system designs created in S3D for this effort did not include any margins or allowances, which led to a discrepancy when comparing

S3D data to ASSET data. In addition, the margins and allowances inherent in ASSET led to sizing of power generation and cooling equipment that is larger than necessitated by the original, un-margined equipment, which is evident during S3D simulations in which the installed generation equipment is not taxed by the loads.

Also, in a bottom-up design system such as S3D, there is definite possibility that accumulating errors and uncertainty can become significant in size and overwhelm the results shown.

Both of these areas require additional attention, along with a consideration of the impact of risk and uncertainty on the design process. There are tasks within the upcoming ESRDC contract to investigate risk.

6.3.10 Semi-Automated Design Assistance

There are several areas in which design assistance would be valuable to the process; the term semi-automated is used to indicate that the engineer is involved in the process but makes use of algorithms and code to complete designs.

Patterns and Templates

Manual construction of distribution systems from scratch is extremely time consuming and prone to error. Creation of templates that can be reused and modified from one design to the next would significantly improve the process. As an example, the current design exercise focused on the liquid cooling systems (seawater, fresh water and chilled water) to manage the generated thermal load. Heat exchangers and chillers were used to reject the heat loads to seawater systems. There are additional distributed systems (e.g. firefighting and compressed air) which are required but have not yet been explicitly addressed in S3D. These systems are relatively well defined and feature common components and configurations that lend themselves to the development of templates to assist the designer in customizing a basic configuration for a specific ship design. This enhancement could be implemented in either the Thermal and Fluids Designer or the Mechanical Designer.

The concept of templates and patterns is under development within the Navy, with ESRDC support.

Automated One-Line Diagram Layout Assistance

It is possible when aligning equipment in the two-dimensional design spaces to arrange and connect the equipment in a manner that does not properly take the three-dimensional location of the equipment into consideration; the converse is also true. As an example, if water-cooled components are connected to one another without regard to three-dimensional location, then piping runs can be excessively long and can cross a compartment multiple times. Similar difficulties can occur in any discipline with distribution components such as piping, cabling or shafting. While it is possible to see these problems by examining the rendering in the 3D visualizer, it is difficult to visually resolve these issues in a complicated ship with a large number

of components and connections. During this exercise, some procedural rules were implemented to help combat this difficulty, such as a naming convention that included zonal affiliation of equipment and port/starboard designation. In addition, significant time was spent auditing locations, weights, sizes and other properties. Automated placement assistance could alleviate this difficulty to some degree. For example, if equipment has been placed in the 3D tool, the initial placement in the 2D page could be automated, and then icons could be manually moved by the user to make the schematic more visually appealing or usable.

7 Summary

This ship design exercise represents the first focused attempt at using a small team of designers working in the collaborative S3D design environment to perform iterative design cycles on a specific ship design target. To guide the design effort, the team developed a realistic set of ship requirements and mission loads using publicly available data. Detailed subsystem designs were then developed for the baseline model using conventional design practices and currently available power generation and power conversion technologies. The baseline design includes detailed electrical and thermal system schematics and a 3D arrangement of major equipment, ducting and cabling.

After development of the baseline design the team developed four variants to explore the impact of high-speed power generation, advanced material power conversion and alternative distribution architectures. The initial design variants represent near-term power system technologies that have the potential for significant impact on the size, performance and cost of power systems for future surface combatants. The effort also provided significant feedback to ESRDC researchers developing S3D, identifying potential improvements for future releases of the tool.

The ship design team has progressed to a new study using a similar methodology to investigate the effects of High-Temperature Superconducting equipment on a medium-sized surface combatant.

8 References

- Babae, H., J. Chalfant, C. Chryssostomidis, A. B. Sanfiorenzo, "System-level Analysis of Chilled Water Systems Aboard Naval Ships," in *IEEE Electric Ship Technologies Symposium, IEEE ESTS 2015*, Alexandria, VA, June 21-24, 2015, pp, 370-375.
- Bernardes, J.S.; Stumborg, M.F.; Jean, T.E., "Analysis of a capacitor-based pulsed-power system for driving long-range electromagnetic guns," *Magnetics, IEEE Transactions on* , vol.39, no.1, pp.486,490, Jan. 2003 doi: 10.1109/TMAG.2002.806380.
- Calfo, R. M., Poole, G. E. and Tessaro, J. E., (2008), "High Frequency AC Power System", *Naval Engineers Journal*, 120: 45–54, 2008.
- Card, A., M. Mazzola, G. Henley, "Early Stage Design Tool for Marine Power Interconnect Systems," in *IEEE Electric Ship Technologies Symposium, IEEE ESTS 2015*, Alexandria, VA, June 21-24, 2015, pp. 349-352.
- Chalfant, J., "Early-Stage Design for Electric Ship," *Proceedings of the IEEE on Electric Ship Technologies*, Vol. 103, Issue 12, 20 August 2015, pp. 2252-2266.

- Chiocchio, T., Schrattecker, R., Yang, S., Ordonez, J., & Steurer, M. Developing a validated real-time system-level thermal simulation for future all-electric ships. In 2013 5th IEEE Electric Ship Technologies Symposium, ESTS 2013, pp. 76-81, Arlington, VA., April 22-24, 2013.
- Doerry, Norbert, "MVDC System Stability", Controls Workshop, The University of New Mexico, July 28, 2016.
- Dresser-Rand, <http://www.dresser-rand.com/wp-content/uploads/2015/01/85209-GasTurbineBro.pdf>, 2015.
- DRS Technologies, <http://www.drs.com/media/2178/drs-catalog-2013-final-online.pdf>, 2013.
- Ericson, Terry, personal correspondence, Dec 2014.
- Ferrante, M., J. Chalfant, C. Chryssostomidis, B. Langland, R. Dougal, "Adding Simulation Capability to Early-Stage Ship Design," in *IEEE Electric Ship Technologies Symposium, IEEE ESTS 2015*, Alexandria, VA, June 21-24, 2015, pp, 207-212.
- GE Marine, LM500 Marine Gas Turbine Data Sheet, 2014.
- GE Marine, LM2500+G4 Marine Gas Turbine Data Sheet, 2014.
- Langland, B.; Rod Leonard; Richard Smart; Roger A. Dougal, Modeling and data exchange in a concurrent and collaborative design environment for electric ships, *2015 IEEE Electric Ship Technologies Symposium (ESTS)*, Year: 2015, Pages: 388 – 394.
- NAVSEA, *Users Guide for Expanded Ship Work Breakdown Structure (ESWBS) for All Ships and Ship/Combat Systems*, S9040-AA-IDX-020/SWBS 5D Volumes 1 and 2l
- QinetiQ, "Paramarine", <http://www.paramarine.qinetiq.com>
- Rahman, M. M., Thamir K. Ibrahim and Ahmed N. Abdalla, "Thermodynamic performance analysis of gas-turbine power-plant", *International Journal of the Physical Sciences* Vol. 6(14), pp. 3539-3550, 18 July, 2011.
- Soltau, N.; Lenke, R. U.; de Doncker, R. W., "High-Power DC-DC Converter", *E.ON Energy Research Center Series* Volume 5, Issue 5, 2014.
- Sudhoff, S., "ESRDC Designing and Powering the Future Fleet (N000141410160), Task 2.9.1 Metamodeling of Power System Components", Interim Technical Report, August 10, 2015.
- University of Texas Contract Award Number N00014-12-1-0289, "Pulse Power Hybrid Energy Storage Module Development Program", 2014.

Appendix A: Roles

As intended, this project has been a collaborative effort to such an extent that it is somewhat difficult to separate exactly what was accomplished by each university. This is in part due to the concurrent collaborative nature of the S3D tool which allows all to have simultaneous access to the same design. The primary Naval Architecture and Marine Engineering expertise was provided by MIT; expertise in electro-mechanical engineering and large machines was provided by UT; S3D software and coding expertise and ship system expertise was provided by USC; and all three universities contributed electrical engineering and thermal engineering. MSU provided input and use of the cable calculator. The core team is as follows:

- Blake Langland, USC: S3D Software Design
- Rich Smart, USC: Thermal Design
- John Herbst, UT: Machinery Design, Power Generation and Conversion, Energy Storage
- Julie Chalfant, MIT: Naval Architecture, Ship Design & Operations, Cooling Systems
- Angie Card, MSU: Cables
- Angelo Gattozzi, UT: Electrical Engineering

These core team members led the project, accomplished the bulk of the design work, and performed the role of soliciting input and facilitating the inclusion of external research into the overall design project. As such, they drew upon the expertise available within ESRDC, ONR, NSWC and other research entities, and also drew upon researchers within their immediate working groups for rapid response when required, especially in the areas of electrical and thermal system design.

While the work was truly collaborative, each university took the lead in specific areas, as follows:

UT

- EM Gun mission load data and modeling within S3D
- Gas turbine, generator and propulsion motor data
- Electrical system modeling
- High-speed turbine generators
- Revised topology modeling
- Mechanical-electrical hybrid equipment modeling
- Mission analysis

USC

- S3D coding and model troubleshooting
- S3D component modeling
- Thermal system design and simulation

- Mission analysis

MIT

- Development of ship requirements and mission loads
- ASSET and Paramarine modeling
- System integration and operations
- Electrical system designs
- 3D layout
- Metrics comparison
- Mission analysis

MSU

- Cable sizing

Appendix B: Payload Equipment Details

B.1 Payload Assumptions

One of the initial actions in the project was to generate a set of payload equipment for a representative medium-sized surface combatant that met a reasonable mix of requirements, included many new components that would tax the support systems in the amount and complexity of support required, and that provided a significant power demand. The final list of payload equipment is shown in Tables B.1 through B.3. Reference material and assumptions for sizes and weights is discussed below.

Table B.1. Payload list.

Armament
Railgun
LASER
Active Denial System
Command and Surveillance
Multi-Function Phased-Array Radar
Integrated Topside (InTop), including Surface Electronic Warfare Improvement Program (SEWIP) and communications
Hull Mounted Sonar, Towed-Array Sonar
Total Ship Computing Environment (Integrated weapons, sensor, machinery and navigation control systems)
Vehicles
Helicopter/UAV
Small Boats/USV

Table B.2. Sensors and C4I mission equipment.

Equipment Name	Cruise (KW)	Mission (kW)	Cruise Cooling Load (KW)	Mission Cooling Load (KW)	Weight (mt)
S Band radar arrays forward (2)	1250	2500	187.5	375	20
X Band radar arrays forward (2)	400	800	60	120	5
S Band radar arrays aft (1)	625	1250	187.5	375	10
X Band radar arrays aft (1)	200	400	60	120	2.5
S Band radar support equipment (forward)	0	0	250	500	40
X Band radar support equipment (forward)	0	0	80	160	28
S Band radar support equipment (aft)	0	0	250	500	20
X Band radar support equipment (aft)	0	0	80	160	14
Integrated Topside (port)	500	2000	250	1000	2
Integrated Topside below deck equipment (port)	0	0	125	500	2
Integrated Topside (starboard)	500	2000	250	1000	2
Integrated Topside below deck eq. (starboard)	0	0	125	500	2

Bow sonar dome water and structure	0	0	0	0	72
Bow sonar sensor	0	400	0	0	30
Bow sonar electrical equipment	0	0	0	100	17
Sonar towed array and electronics	0	100	0	0	2
Sonar towed array towing system	0	50	0	37.5	15
Total ship computing environment	150	150	60	60	40

Table B.3. Weapons mission equipment.

Equipment Name	Cruise (KW)	Mission (kW)	Cruise Cooling Load (KW)	Mission Cooling Load (KW)	Weight (mt)
32 MJ rail gun mount	0	0	0	7304	80
Rail gun pulse forming network	500	17000	59	1992	210
Rail gun magazines and launch packages	0	0	0	0	20
Laser	0	0	0	0	5
Laser below deck equipment	0	1200	0	900	5
Active denial system array	0	600	0	0	1
Active denial system support equipment	0	0	0	195	1
Vertical launch system 8 Cell forward x4	240	480	60	120	58
Vertical launch system loadout	0	0	0	0	92
Vertical launch system weapons control system	0	500	0	250	1
Vertical launch system 8 Cell aft x4	240	480	60	120	58
Vertical launch system loadout	0	0	60	0	92

B.2 Railgun

Assumptions: 30 MJ gun with 1000 round storage, rep rate 10 shots per minute

Dimensions: 10 x 10 x 12m [5], for entire system (includes mount, ammunition handling and storage, power electronics, cooling)

Weight:

Mount: 80 mt [1,2,3]

Pulse Forming Network [5]: 210 mt for a 64 MJ system

Ammunition: 20 mt (1000 rounds x 10 kg/round [6], then double for storage/handling)

Cooling Skid (heat exchangers): No estimate

Power: 30 MJ at 10 shots/min, assume 5 sec charge and 1 sec discharge/recovery = average 10 MW

Cooling: Assume 40% efficient: 10% lost in pulse forming network (PFN), 50% lost in rails [5]. We assume a separate cooling system for the rails, so the only losses are in the pulse forming network.

B.3 LASER

Power: today's technology LASER is 100-150kW [7]; assume future laser is 300kW radiated, at 25% efficiency [7], requiring 1200kW supply.

Cooling: Reference [7] slide 6 states 25% efficiency, thus 900 kW of cooling needed. Assume water cooled, and assume all cooling goes to laser source which is below decks (see diagram slide 6), so do not need antifreeze.

Weight: Reference [8] slide 15 states 10,000 lbs for optics, excluding power supply and cooling. Assume power supply and cooling weight equal to optics weight at 5 mt each.

Dimensions: Reference [8] slide 7 gives 4m x 4m x 30m for a system between 0.1 – 1 MW. Looking at pictures of system in reference [7] slide 7 and 8, the topside portion looks about 4m x 4m x 3m, and below decks portion could be about the size of a conex box, excluding cooling; we assume 6m x 4m x 3m.

B.4 Active Denial System

Dimensions and weight: From [9], compact ADT desired size is 36 ft³ with a weight of approximately 1000 lbs; we assume this is for support equipment for a single array. From [10], antenna is 86"x86", and looks to be about 25" in depth. We assume the antenna weight is equal to the support equipment weight, and place two antennas with support equipment onboard. Thus, use:

Array: 1 mt for 2 arrays, each 2m x .6m x 2m.

Support equipment: 1 mt for 2 arrays, each 1m x 1m x 1m

Power: From [9], max power output should be 100 kW; at 35% efficiency, this requires about 285 kW input; we assume 300 kW each, or 600 kW total.

Cooling: From [9], desired efficiency of solid state version is 35%. Assume liquid cooled, with chill water supplied to the support equipment location.

B.5 Vertical Launching System (VLS)

Data assimilated from [4, 11, 12].

Weight and Dimensions: use weight and dimensions from [4] for 8-cell strike module VLS; Module dimensions: 3.4m x 2.54m x 7.7m; module weight: 14.5 mt; missile weight: 23 mt
Off-module equipment dimensions: 4m x 1m x 2m (including space around equipment), off-module equipment weight: 1 mt

Power: Power from [12] is ~17kW per 4-cell unit, assume 35kW per 8-cell module. Assume 500 kW for weapons control system.

Cooling: Assume air cooled, 75% efficient.

B.6 Dual Band Radar

Power: Total power described in the DBR brochure [13] is 2MW. We will assume 500 kW per S-band array, 200 kW per X-band array, with 2 arrays forward and 1 aft of each (6 total arrays, 3 each X- and S- band). Assume required power at cruise is ½ of the required power at full mission load.

Our installed version we assume is an upgrade to 1250 kW per S-band, 400 kW per X-band.

Cooling: Efficiency from the DBR brochure [13] is 30%. Assume half the losses occur in the array and half the losses occur in the support equipment. Assume both are water cooled. Dimensions/weight of cooling equipment is assumed to be included in the “below decks equipment” described below.

Weight: Assume X-band arrays are 2.5 mt each, S-band arrays are 10 mt each. X-band support equipment weight is 7 mt per array, S-band below decks equipment is 10 mt per array, for a total below decks weight of 21 mt and 30 mt for X-band and S-band respectively. The below decks weight is assumed to include electronics and the dedicated cooling system (which requires 900 GPM@11C chilled water for 2MW). [13]

As an initial estimate for the increased power equipment, array weights will stay constant, support equipment weight will double.

Dimensions: X-band array dimensions are 2.5m x 2.5m x 1m (height x width x depth); S-band array dimensions are 4m x 4m x 1m [13]. For below-decks equipment, assume 10m x 10m x 2m space required forward and aft.

Keep dimensions constant for increased power equipment.

B.7 InTop Array

An integrated topside (InTop) array will provide all radio-frequency spectrum needs, including electronic warfare, information operations and communications.

Data assimilated from [14, 16].

Weight: Assume 2 mt per antenna [14], with equal weight for support equipment for each antenna.

Dimensions: Assume 2m x 1m x 1m per antenna, 2.5m x 2.5m x 2.5m for support equipment per antenna.

Power: Assume total radiated power for all functions is 1MW; at 25% efficiency, requires 4 MW of supplied power.

Cooling: Assume 25% efficient, water cooled. 1/3 of losses occur in support equipment, 2/3 occur at apertures.

B.8 Sonar

Data assimilated from [14, 17, 18, 19, 20]

Bow-mounted Sonar

Dimensions: Array 5m x 5m x 1.5m; Electronics 7m x 12m x 2m (3 rows of 10 cabinets, 1 m wide each plus 1m on each end, 1 m space between each row plus 1m front and back = 7m x 12 m = 84m²)

Weight: Array 30 mt; Electronics 17 mt; Dome structure and water: 72 mt (5 m diameter by 1.5 m height times seawater density of 1.025 mt/m³, assume 60% full).

Power: Assume 100 kW output, 25% efficiency, requires 400kW

Cooling: Array is submerged in seawater, electronics are air cooled. Assume 25% overall efficiency with 25% loss in electronics and 50% loss in array.

Towed-array sonar

Dimensions: Handling winch and drum: 8m x 8m x 2m (handling equipment is approx. 6m x 4m x 3m, increase to 8m x 8m for personnel work area); Support Electronics: 10m x 5m x 2m (2 rows of 8 cabinets)

Weight: Array: 2 mt; Handling winch: 15 mt

B.9 Total Ship Computing Environment

Power: 300 W x 250 computers = 75 kW; plus inefficiency, cooling, etc. → 150 kW

Weight: 300 lb x 250 computers = 40 mt; assume includes cooling, cabling, foundations, etc.

Cooling: Assume 60% efficient

Dimensions: Assume 5 computers per stack, 50 stacks, 1 m² per stack, plus 3 m² space = 200 m²

B.10 Helicopters

Data assimilated from [21, 22, 23, 24].

Power/cooling: assume power is off for helicopter support equipment.

Weight: Helicopters 10 mt each; Support equipment: assume 20 mt ; fuel: assume 500 lbs (.25 mt) fuel/helo/trip, 10 trips per day for 14 days = 77 mt fuel; RAST: assume recovery winch system is about same weight as towed array sonar recovery system, double weight to account for transversing capability. Missiles: 50 kg each, double weight for storage, take 100 rounds;

Dimensions: Hangar/support space: use 14m x 10m x 4.6m for hangar; double hangar footprint to include support and storage. Assume RAST is same length as hangar, about 4 m wide, total 56 m². Missiles: assume .5 m² each for storage, total 100 rounds.

B.11 Boats

Following assumptions are for two 11-meter RHIB boats [25]. Assume USV loadout, if required, would replace one RHIB and its support equipment.

Weight: assume 8 mt each for 2 boats, support equipment assume 15 mt for each boat (same weight as towed array handling system).

Dimensions: assume 12m x 5m x 5m area which includes winch, cradle, support equipment.

Power/cooling: assume winches not operating at mission or cruise load.

B.12 References

1. Bennett, P. and R. D. Scott, "DDG-51 Flight I Rail Gun Conversion", web.mit.edu/2n/Abst-ExecSum/2006/Conversion/DDG51-RAILGUN.pdf, 2006.
2. Johnson, A., E. West, B. Miller, F. Zouridakis, "DD(X) Rail gun Conversion Feasibility Study", [web.mit.edu/2n/Abst-ExecSum/2004/Conversion/DD\(X\)-RAILGUN.pdf](http://web.mit.edu/2n/Abst-ExecSum/2004/Conversion/DD(X)-RAILGUN.pdf), 2006.
3. Higgins, J., J. Rhoads, M. Roach, "Advanced Gun System (AGS) Backfit", <https://dspace.mit.edu/bitstream/id/3172/AGS+Conversion+Study.pdf>, 2003.
4. IHS Jane's weapons. Naval. Coulsdon: IHS Global 2013-14.
5. Bernardes, J., M. Stumborg, and T. Jean, "Analysis of a Capacitor-Based Pulsed-Power System for Driving Long-Range Electromagnetic Guns," *IEEE TRANSACTIONS ON MAGNETICS*, VOL. 39, NO. 1, JANUARY 2003.
6. <http://en.wikipedia.org/wiki/Railgun>
7. Morrison, R., "Navy Solid State Laser Program Overview", June 2, 2014.

8. Sprangle, P., "Laser Weapons for Naval Applications," American Society of Naval Engineers (ASNE) Combat Systems Symposium, Arlington, VA, March 27, 2012.
9. BAA 14-008, "Joint Non-Lethal Weapons Program Fiscal Year 2015 Non-Lethal Weapon Technologies", 2015.
10. Miller, S. and G. Svitak, "NATO NAVAL ARMAMENTS GROUP Workshop on Counter Piracy Equipment and Technologies", Raytheon Company, June 4, 2009.
11. BAE Systems, "MK 57 Vertical Launching System, Zumwalt Class Destroyer Program", Raytheon Company, 2005.
12. BAE Systems, "Vertical Launching System (VLS) Mk 41 Strike-Length Module", 2011.
13. Raytheon, "DDG 1000 Dual Band Radar (DBR)", 2000-2006.
14. Friedman, N., *The Naval Institute Guide to World Naval Weapons Systems*, Naval Institute Press, Annapolis, MD, 1997-98.
15. <http://www.lockheedmartin.com/us/products/electronic-warfare.html>
16. Spatially-Distributed Electron Beam Technology for Millimeter-Wave Amplifiers; Navy SBIR 2012.1 - Topic N121-046; http://www.navysbir.com/n12_1/N121-046.htm
17. Thales, "UMS 4110 Low Frequency Active and Passive Bow Mounted Sonar (BMS) for Medium to Large Platforms", Thales Underwater Systems SAS, 2012.
18. L-3 Oceans Group, "HS-100 Multifunction Hull-Mounted Sonar", 2007.
19. http://en.wikipedia.org/wiki/Marine_mammals_and_sonar
20. <http://en.wikipedia.org/wiki/AN/SQS-26>
21. Polmar, N., *The Naval Institute Guide to the Ships and Aircraft of the U.S. Fleet,* Fifteenth Edition, Naval Institute Press, Annapolis, MD, 1993.
22. From <http://www.mh-60.com/mh-60s/>
23. <http://www.hazegray.org/worldnav/usa/surface.htm#dd>:
24. http://en.wikipedia.org/wiki/AGM-114_Hellfire
25. http://www.navy.mil/navydata/fact_display.asp?cid=4200&tid=2200&ct=4

Appendix C: Baseline System Diagrams from S3D

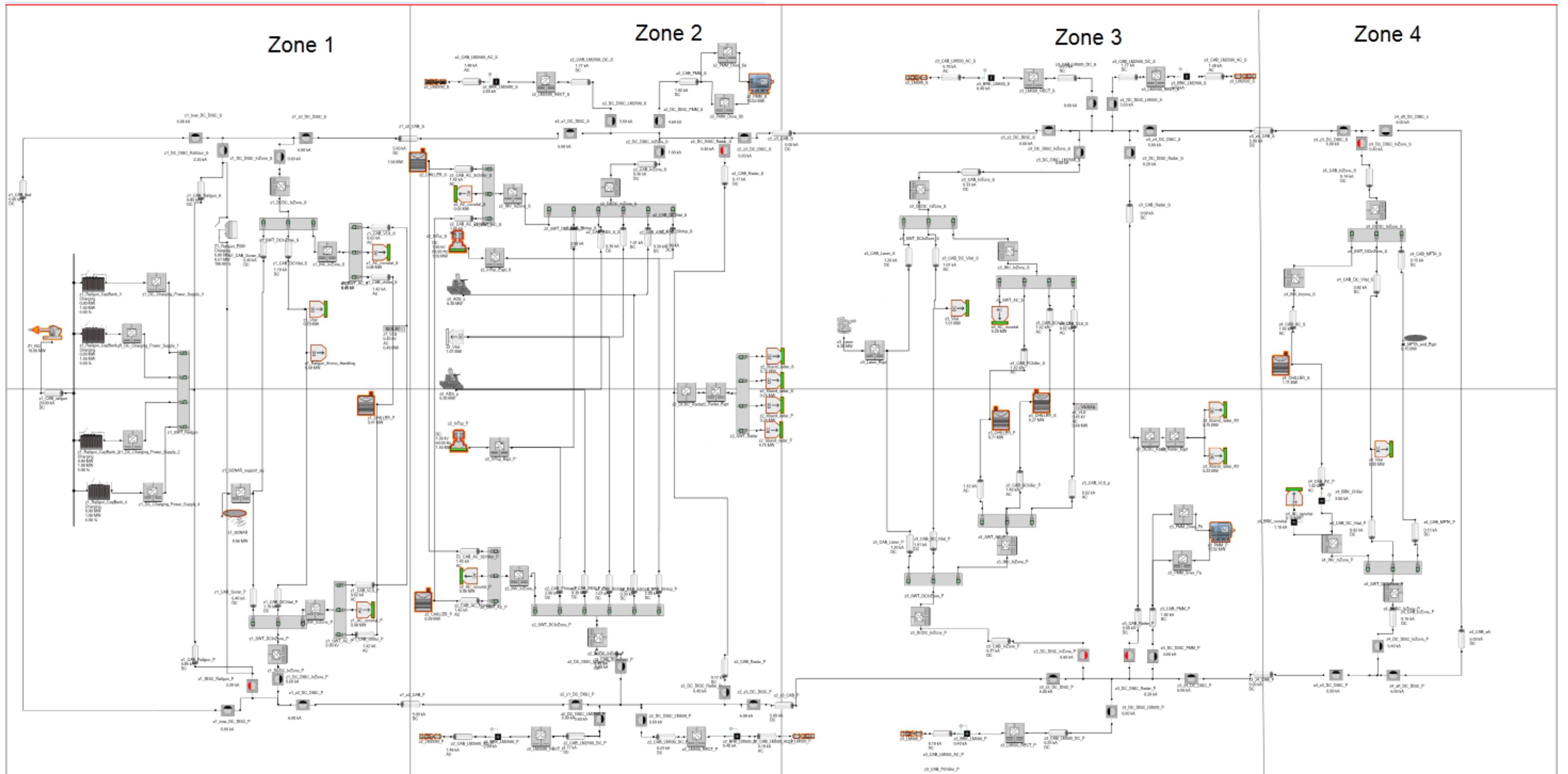

Figure C.1. Electrical schematic of baseline design in S3D.

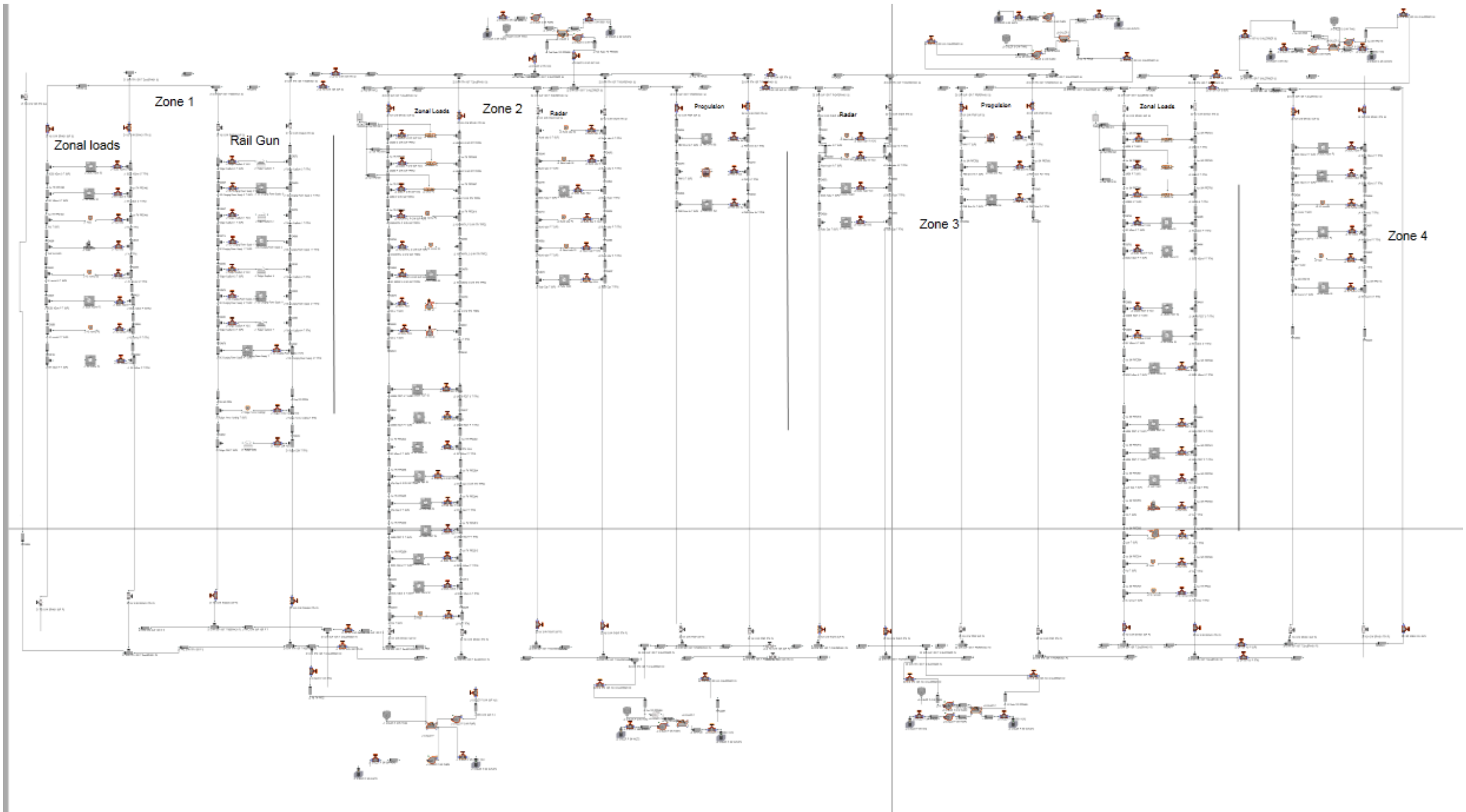

Figure C.2. Thermal piping schematic of baseline design in S3D.

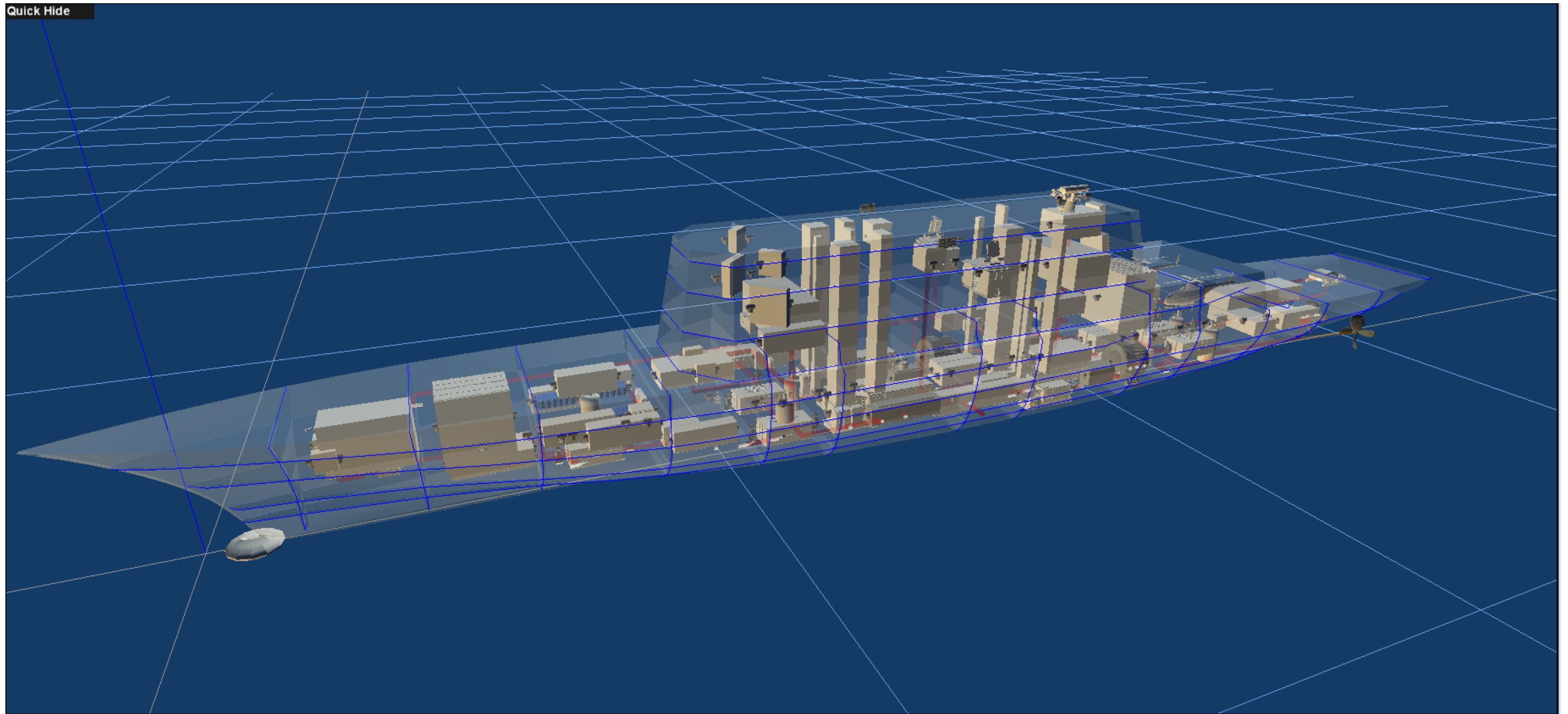

Figure C.3. Equipment arrangement using 3D visualization tool in naval architecture workspace.

Appendix D: Equipment Help Files Examples

D.1 Pump Flow Rate

D.1.1 Functionality



D.1.1.1 Model Capabilities

D.1.1.1.1 Functional description

The Pump Flow Rate is a piece of equipment used to provide fluid flow through a hydraulic circuit using electrical power. An electrical motor is used to convert the electrical power into mechanical power required to move the fluid.

This device is capable of producing a specified fluid flow rate to a hydraulic circuit. The equipment will always attempt to converge the fluid flow rate to the value specified by its “Liquid Mass Flow Rate” attribute. Due to this, the pressure across the equipment will be dependent upon the pipe resistance of the equipment. The pump will attempt to achieve a constant flow rate by increasing the pressure from the pump. This effect could result in a high pressure across the equipment and will need to be handled by the user.

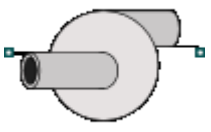
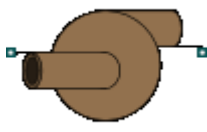
D.1.1.1.2 Control Modes

Notional	State	Non-notional
	Offline	
	Online	

D.1.1.1.3 Special Actions

Double Clicking

Double clicking the pump flow rate icon will cause the equipment to cycle the “Online” attribute between true and false. For instance, if the pump is double clicked while the “Online” attribute is set to true, then the attribute will become false and vice versa.

D.1.1.2 Cross-Discipline Effects

The pump flow rate will require electrical power to supply the needed flow rate to the system. An equivalent model of this system will be created in the Electrical Designer with the placement of the equipment in the Thermal Designer. The user will need to supply electrical power to the pump in the Electrical Designer. If the simulation of the pump is run without electrical power being supplied to it, a warning will be raised stating that the pump does not have the required amount of power. This can be seen in the Simulation Event section.

D.1.1.3 Operating range limitations

This model will produce results even when it is being operated without the required amount of electrical power supplied. In addition, the model will produce results when it is being operated out of bounds set by “Rupture Pressure” attribute. The user will need to pay attention to warning in order to determine if the Pump Flow Rate is being properly used.

D.1.1.4 Assumptions

The system impedances allow the pump flow rate to provide the requested flow rate. A situation resulting in the inability to allow the flow rate will result in a simulation result that is unable to converge.

D.1.2 Fault Modeling

D.1.2.1.1 Simulation Events

Not enough Electrical Power Supplied

This event is raised by the simulation model whenever the actual electrical power requested from the Electrical Designer system is not provided to the pump. An example of this warning can be seen below. This problem can be solved by opening the Electrical Designer and providing power to the pump

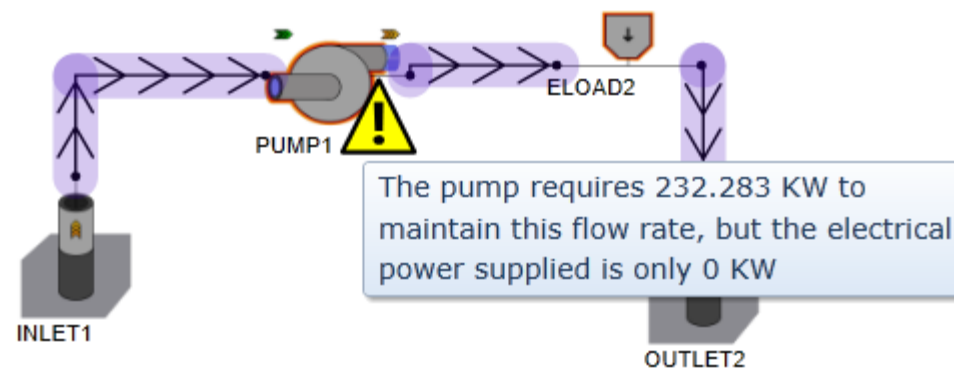

Figure D.1 Pump needs electrical power supplied in the Electrical Designer.

D.1.3 Analytical Methods

D.1.3.1 General Algorithms

The model consists two distinct sections: one that computes pressure and flow-rates, and one that handles the thermal aspects.

For the pressure and flow-rate computations, the models are responsible for providing a Jacobian matrix contribution and equivalent vector. The solver combines these into system-wide variables and solve the system of equations using a Modified Nodal Analysis (MNA) approach.

Once flow results are known, flow direction is used to determine the order models are stepped, and the thermal analysis is a signal-based input-output system. Each component model retrieves the temperature of the coolant flowing in, and computes the temperature of the coolant flowing out, and it is responsible for determining that based on the fluid properties of the coolant.

D.1.3.2 Analytical Capabilities

Steady-state flow-rate and pressure analysis. Signal-based thermal analysis.

D.1.4 Data

D.1.4.1 Attributes

D.1.4.1.1 Equipment Attributes

Fluid Type

This attribute designates the type of coolant that will be flowing through the pump. This attribute is an enumeration and therefore all possible coolants are predefined by the attribute. This attribute will be defined by the simulation and will be propagated from the coolant source.

Liquid Mass Flow Rate

This attribute designates the amount of flow that the pump will provide to the system. This attribute will remain constant in an open circuit. This will cause the pressure to raise accordingly based on the pipe resistance of the following components.

Online

If this attribute is set to false, the pump will not provide flow to the hydraulic circuit. If the attribute is set to true, the pump will attempt to provide the flow rate designated by the “Liquid Mass Flow Rate” attribute.

D.1.5 User Guidelines

D.1.5.1 Test Cases

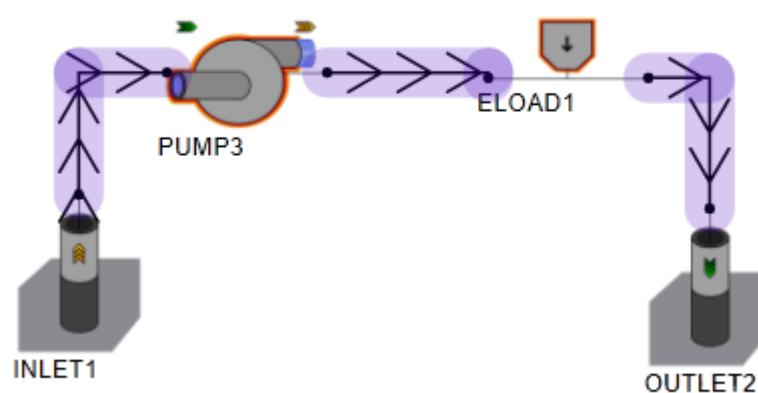

Figure D.2. Example system of pump providing fluid flow-rate through a system.

D.2 Motor

D.2.1 Functionality

D.2.1.1 Model Capabilities

D.2.1.1.1 Functional description

The AC Motor is used in the electrical discipline to simulate the amount of power consumed to produce the torque requested from the motor in the mechanical discipline. In the mechanical discipline, the motor acts as a source. In the electrical discipline, the motor acts similarly to an electrical load.

This device is capable of requesting power from electrical sources. The equipment has an attribute, “Rated Electrical Power”, that specifies the maximum power the motor should draw. This attribute should be set to the value appropriate for the actual equipment that it represents. During simulation, the user will be warned if the electrical power to the motor exceeds the “Rated Electrical Power.” The port attributes specify the voltage, current type, and frequency. These attributes will need to match the port attributes of all the equipment that it is connected.

The “Actual Electrical Power” attribute defines how much electrical power the motor requests when driving a load. The actual electrical power is determined from the motor’s efficiency and the “Mechanical Power Supplied” (Actual Mechanical Power).

$$P_{Electrical} = \frac{P_{Mechanical}}{\varepsilon}$$

The general power-flow system of equations used is of the form shown in Eq. 0.1. The solver can use a variety of methods to solve this system, such as Gauss-Seidel or Newton-Raphson to solve for the V vector.

$$S = V \cdot \sum_{k=1}^n Y_k^* \cdot V_k^* \quad Eq. 0.1$$

The length of S and V vectors is equal to the total number of nodes n , and the Y matrix is of size $n \times n$. From the individual model’s perspective, n represents the total number of ports in the model, under the assumption that they may each be connected to a different node. If multiple ports are shorted into the same node, the solver is responsible for combining the equations into one node equation.

Load models are responsible for supplying the value of S . The model is therefore represented by Eq. 0.2.

$$S = -ActualElectricalPower \quad Eq. 0.2$$

D.2.1.1.2 Control Modes

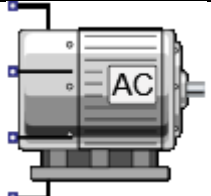
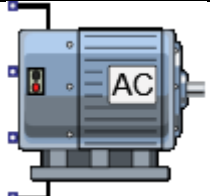
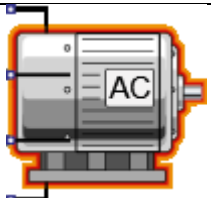
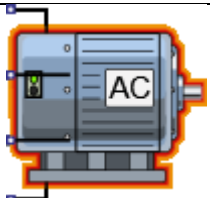
Notional	State	Non-notional
	Offline	
	Online	

D.2.1.1.3 Special Actions

Double Clicking the motor icon causes the motor to cycle between the online and offline states. For instance, if the motor is double clicked while the “Online” attribute is set to true, then the attribute will become false (taking the motor offline) and vice versa.

D.2.1.2 Cross-Discipline Effects

The Twelve-Phase AC Motor in the electrical discipline is used to model the amount of electrical power required to supply the amount of power being requested in the mechanical discipline. If a load that the motor is providing power to in the mechanical discipline changes, then the amount of power that the motor needs to provide will likewise change. In essence, this means that the amount of power that the motor needs in the electrical discipline will also change.

Due to the inefficiencies of the motor there will be losses in the form of heat. Therefore, an equivalent motor model exists in the thermal disciplines in order to model the cooling requirements of the motor. The amount of power needed to cool the motor is the difference between the “Actual Electrical Power” and the “Actual Mechanical Power”

D.2.1.3 Operating range limitations

This model will produce results even when it is being operated out of the bounds set by the “Rated Electrical Power” attribute. The user will need to pay attention to warnings in order to determine if the motor is being properly used.

D.2.2 Fault Modeling

D.2.2.1 Simulation Events

D.2.2.2.1 Electrical Power Greater Than Rating

This event is raised by the simulation model whenever the “Actual Electrical Power” produced by the motor is greater than the setting for the “Rated Electrical Power” attribute. An example is shown in Figure D.3.

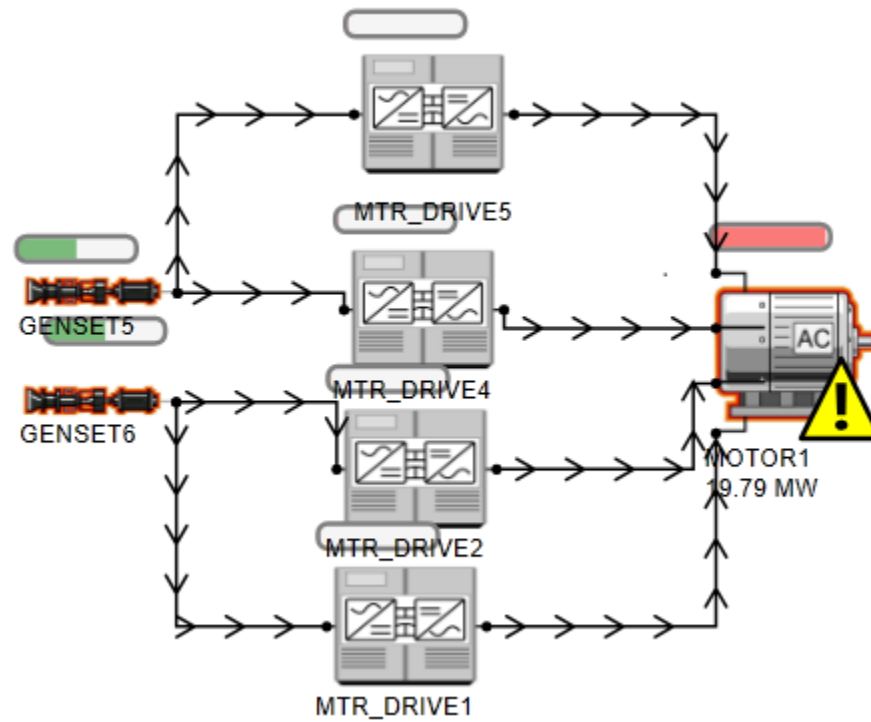

Figure D.3. An example of the "Electrical Power Greater than Rating" simulation event. The amount of power being drawn by the load is greater than the "Rated Electrical Power" attribute value.

D.2.3 Analytical Methods

D.2.3.1 General Algorithms

ZIP load-flow model. Provides constant power injection to the load-flow system model and voltage magnitude.

The solver uses the constant power injection provided to solve for system steady-state voltages at every node as well as currents and power flow through every branch using known algorithms such as Gauss-Seidel and Newton-Raphson methods.

D.2.3.2 Analytical Capabilities

Steady-State, load-flow analysis.

D.2.4 Data

D.2.4.1 Attributes

D.2.4.1.1 Equipment Attributes

Actual Electrical Power

Defines how much power the motor is requesting from the system in the current context. This value is calculated from the analysis results of the Machinery Designer. The Actual Mechanical Power and the Efficiency are used to calculate this value.

Efficiency

Defines the percentage of power that will be successfully converted from electrical energy to mechanical energy. The losses are modeled as heat. The heat will need to be transferred from the equipment using the motor model in the Thermal Designer.

Electrical Percent Power Efficiency Curve

The result of this curve yields the efficiency value. The values used to calculate percent of power is the Actual Electrical Power and Rated Electrical Power.

$$\varepsilon \left(\frac{P_{Actual}}{P_{Rated}} \right)$$

For example, as shown by the figure below, if the actual power is 60% of the rated power, the resulting efficiency of the motor will be 95%

Online

If this attribute is set to true the motor will request power from the system. If this attribute is set to false, the motor will not request power from the system. This attribute can manually be changed by editing the attribute in the property tab or by double clicking the icon as described above.

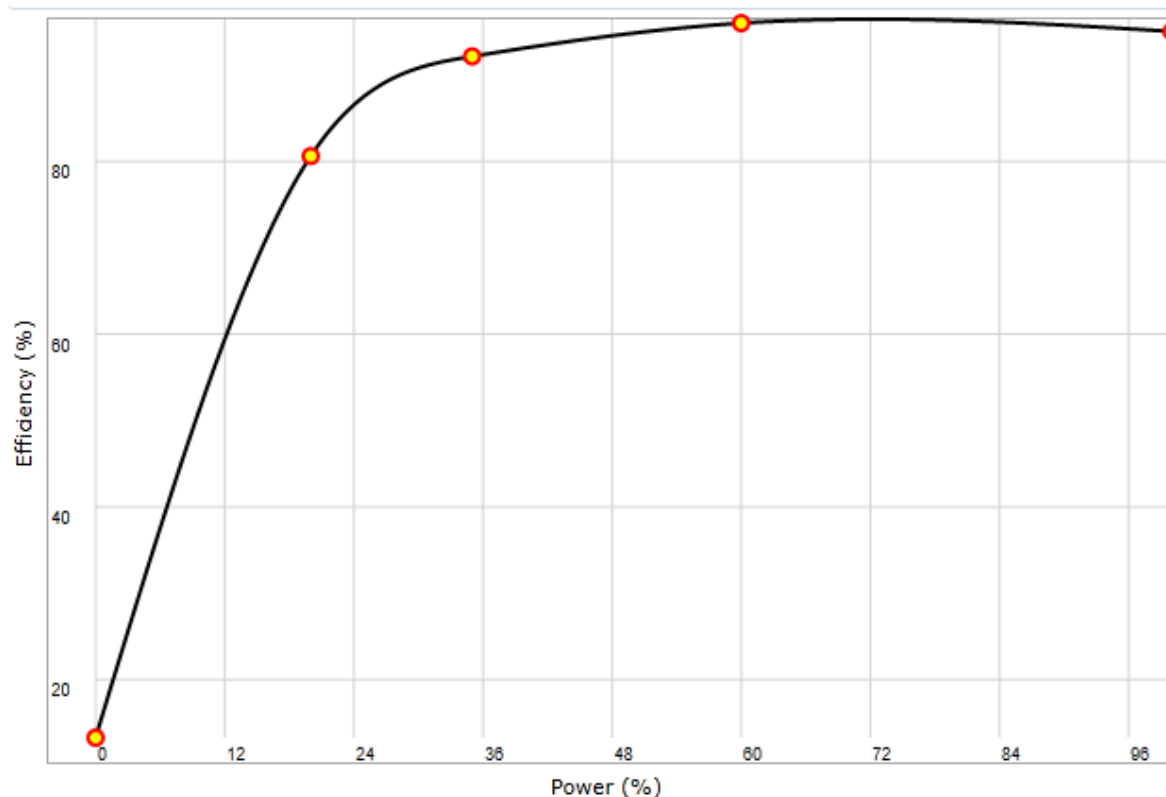

Figure D.4 An example of the "Electrical Percent Power Efficiency Curve" attribute from which the equipment's efficiency will be derived, depending on its current operating point.

Rated Electrical Power

This attribute defines the maximum amount of power the equipment is capable of drawing. As indicated in the Model Limitations section, the equipment will continue to operate if the power drawn is above the Rated Electrical Power but the user will be notified by the Simulation Event "Electrical Power Greater Than Rating." The rated electrical power can be modified as long as the equipment that it is being modeled is notional and not representative of an actual device.

D.2.4.1.2 Port Attributes

Current Type [AC or DC]

This attribute specifies the type of current produced (Alternating Current or Direct Current) at a specific electrical port. In this case, the current type for the motor will be AC. The user will be warned if they attempt to connect the motor to equipment with that requires DC current.

Rated Frequency [Hz]

This attribute specifies the frequency of the electrical port. Typically, this will be 60Hz.

Rated Voltage [kV]

This attribute specifies the voltage requested at the electrical port. Attempting to simulate equipment connected at the same nodes that have different voltages specified for this port will produce a connection error.

D.2.5 User Guidelines

D.2.5.1 Test Cases

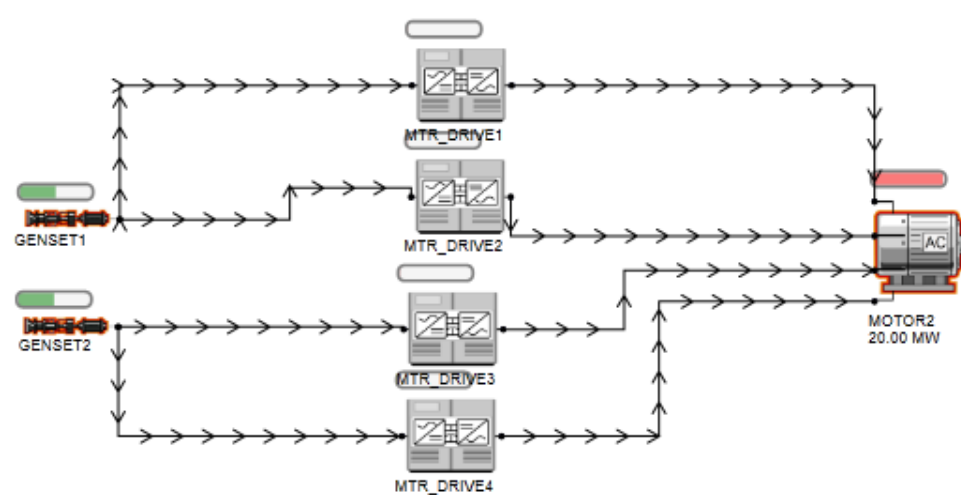

Figure D.5 Two Gensets providing power to a Twelve-Phase motor via four motor drives.

D.3 Abbreviations and Acronyms

Acronym List

ZIP	Standard steady-state load-flow model. Constant impedance (Z), constant current (I), constant power (P).
------------	--

Appendix E: High-Speed Generator

The size and weight of the electric machine is driven by the torque it is required to produce (motor) or absorb (generator). The impact of higher speed operation on the power density of electric machines is significant because of the reduced torque required for a given power. For a rotating electric machine the input or output power is equal to the product of torque and speed. For synchronous electric machines this can be illustrated with a more general power equation:

$$P \propto \underbrace{B \times A_s \times D^2 \times L}_{\text{Torque}} \times \omega$$

where

P = power

B = air gap flux density

A_s = stator line current density

D = airgap diameter

L = machine active length

ω = angular velocity

Holding airgap flux density and stator line current density constant, the product of diameter squared and length required for a given power level decreases in direct proportion to the increase in operating speed.

For the larger gas turbines, the OEM power turbine is typically designed to operate at 3,600 rpm to enable direct drive of 60 Hz synchronous generators. For the high speed generator variant, the design team considered a family of custom 6,200 rpm power turbines developed for the GE LM2500 family of turbines. The Vectra series power turbine design was developed by Dresser-Rand for direct drive of high speed compressors in the oil and gas industry [Dresser-Rand 2015]. Generators for the high speed power generation variant were based on water-cooled high speed generator designs for naval applications published by Curtiss-Wright EMD [Calfo 2008].

Smaller gas turbines typically operate with higher power turbine speeds. The LM500 engine operates with a nominal power turbine speed of 7,000 rpm, normally requiring a gearbox to reduce the output to 1,800 or 3,600 rpm to drive a 60 Hz synchronous generator. In the absence of a comparably detailed design for a water-cooled high speed generator for the LM500, a notional 4 MW, 7,000 rpm generator design was developed and the package size and weight were scaled accordingly.

Direct Water Cooling

Marine motors and generators operating in closed spaces are typically configured as Totally Enclosed Water to Air Cooled (TEWAC) machines. In this design (Figure E.1), shaft- or frame-mounted blowers circulate cooling air through the generator airgap and over the end turns and then through a frame-mounted air-to-water heat exchanger. The water side of the heat exchanger is connected to the ship's sea- or fresh-water cooling loops to manage the thermal losses in the electric machine.



Figure E.1. TEWAC generator showing frame mounted fans and integral water to air heat exchanger.

Direct water-cooled electric machines use coolant passages embedded in or adjacent to the electrical windings and core to manage thermal losses. Coolant tubes can be integrated within the armature and field winding coils and around the OD of the laminated stator core. This design results in more efficient cooling by eliminating the highest thermal resistance in the cooling system and taking advantage of the higher convective heat transfer coefficients possible with liquid heat transfer media. Significant size and weight reductions are realized through more effective heat transfer and elimination of the frame mounted water to air heat exchanger. Direct all water cooled designs require a rotating fluid coupling to interface with the spinning rotor and are typically more complex (and thus more expensive) than more conventional designs. Electrical insulation considerations may also limit the output voltage of the machines and depending on the design, these systems may require de-ionized water which will necessitate the use of a water-to-water heat exchanger (e.g., brazed plate or shell and tube) to interface with the ship's sea- or fresh-water cooling loops. Table E.1 shows some of the design parameters for the LM-2500+ main gas turbine generator sets comparing a conventional 60 Hz air TEWAC machine with a comparable high speed machine and a direct water cooled machine.

Table E.1. Generator design comparison for LM2500+ gas turbines [Calfo et al., 2008].

Parameter	60 Hz TEWAC	206 Hz TEWAC	206 Hz Water Cooled
-----------	-------------	--------------	---------------------

Operating Speed	3,600 rpm	6,200 rpm	6,200 rpm
Power Rating	26 MW	25 MW	25 MW
Efficiency (w/o brg)	98.5 %	97.7 %	98.3 %
Operating Voltage	13.8 kV	6.9 kV	6.9 kV
Number of Poles	2	4	4
Rotor Diameter	32 in	24 in	25 in
Active Length of Core	66.2 in	84 in	36 in
Diameter of Core	65 in	45 in	45 in
Overall Machine Width	126 in	150.5 in	66 in
Overall Machine Height	148 in	122 in	71 in
Overall Machine Length	202 in	200 in	113 in
Machine Weight	163,210 lb	104,600 lb	37,500 lb

It is worth noting that the weight of the 60 Hz, 3,600 rpm generator in Table E.1 is higher than the weight shown for the 60 Hz generator set on the GE LM2500+ datasheet which was used in the baseline design. This example illustrates a significant challenge for the ship design exercise: identifying reliable open-source source data to support the design activity. Direct water cooling and high speed operation enables significant reductions in the weight and volume of the electric machines. These weight and volume reductions are effectively magnified when the reduced weight of the baseplate and supporting hull structures are considered.

For a given pole count, operating the generator at higher rotational speed increases the generator frequency. Operation at higher frequencies will increase the core losses (e.g., eddy current, hysteresis) of the generator which will impact the efficiency. Data for the notional high speed generators was not available so the notional power level versus efficiency curve created for the baseline was modified to reduce the generator efficiency by 0.5%.