

T9640-AC-DSP-010/HAB

REVISION 1

NAVSEA TECHNICAL PUBLICATION

SHIPBOARD HABITABILITY DESIGN CRITERIA AND PRACTICES MANUAL (SURFACE SHIPS) FOR NEW SHIP DESIGNS AND MODERNIZATION



THIS MANUAL SUPERSEDES T9640-AC-DSP-010/HAB DATED 02 JULY 2013.

DISTRIBUTION STATEMENT A: APPROVED FOR PUBLIC RELEASE; DISTRIBUTION UNLIMITED

PUBLISHED BY DIRECTION OF COMMANDER, NAVAL SEA SYSTEMS COMMAND



0910LP1169084

21 DECEMBER 2016

LIST OF EFFECTIVE PAGES

Dispose of superseded pages in accordance with applicable regulations.

Dates of issue for original and subsequent revisions:

Original..... 02 July 2013

Revision 1..... 21 December 2016

TOTAL NUMBER OF PAGES IN THIS PUBLICATION IS 175, CONSISTING OF THE FOLLOWING:

Page No.

Title and A

i-xxii

Part I

1-1 through 1-9/(1-10 blank)

2-1 through 2-31/(2-32 blank)

3-1 through 3-10

4-1/(4-2 blank)

Part II

1-1 through 1-11/(1-12 blank)

2-1 through 2-13/(2-14 blank)

3-1 through 3-7/(3-8 blank)

4-1 through 4-8

5-1 through 5-10

6-1 through 6-7/(6-8 blank)

7-1 through 7-10

8-1 through 8-9/(8-10 blank)

9-1 through 9-4

A-1 through A-5/(A-6 blank)

B-1/(B-2 blank)

TMDER

TABLE OF CONTENTS

Chapter/Paragraph/Title	Page
FOREWORD	XIX
INTRODUCTION	XXI
PART I, DESIGN CRITERIA	I
CHAPTER 1 ENVIRONMENTAL CONTROLS	1-1
1.1 GENERAL	1-1
1.2 HEATING, VENTILATION, AND AIR CONDITIONING (HVAC)	1-1
1.2.1 Ventilation	1-1
1.2.1.1 Intakes.....	1-1
1.2.1.2 Air Exchanges.....	1-1
1.2.2 Heating.....	1-1
1.2.2.1 Heating Season	1-1
1.2.2.2 Heating Sanitary Facilities.....	1-1
1.2.2.3 Heating Medical and Dental Facilities.....	1-1
1.2.2.4 Extensive Cold-Weather Operations.....	1-1
1.2.3 Air Conditioning	1-2
1.2.3.1 Cooling Season	1-2
1.2.3.2 Extensive Warm-Weather Operations	1-2
1.2.4 Heat Stress	1-2
1.2.5 HVAC Terminals in Berthing Spaces.....	1-2
1.2.6 Indoor Climate Measurements.....	1-2
1.3 NOISE AND WHOLE BODY VIBRATION	1-2
1.3.1 Noise.....	1-2
1.3.1.1 Compartment Sound Levels.....	1-2
1.3.1.2 Compartment Treatment Plan	1-3
1.3.1.3 Noise Level Surveys	1-3
1.3.1.4 Consultation with NAVSEA and Navy and Marine Corps Public Health Center (NMCPHC)	1-3
1.3.2 Whole-Body Vibration	1-3
1.4 LIGHTING.....	1-4
1.5 MATERIALS.....	1-5
1.5.1 Carpeting	1-5
1.5.2 Bulkhead and Overhead Sheathing.....	1-5
1.5.2.1 Installation of Sheathing for Health and Sanitary Purposes.....	1-5
1.5.2.2 Installation of Sheathing for Aesthetic Purposes	1-5
1.5.2.3 Application of Sheathing	1-5
1.6 SHIPBOARD HABITABILITY FURNITURE AND EQUIPMENT.....	1-6
1.6.1 Furniture and Equipment	1-6
1.6.2 Additional Requirements for Furniture.....	1-6
1.6.2.1 Styling.....	1-6
1.6.2.2 Size Constraints	1-6
1.6.2.3 Compatibility	1-6

Chapter/Paragraph/Title	Page
1.6.2.4 Attachment to Ship Structure.....	1-6
1.6.2.5 Built-in Furniture.....	1-6
1.6.2.6 Construction.....	1-6
1.6.2.7 Furniture with Horizontal Surfaces.....	1-6
1.6.2.8 Interchangeability.....	1-7
1.6.3 Portable Furniture and Equipment.....	1-7
1.6.4 Installed Furniture and Equipment.....	1-7
1.6.5 Hooks and Racks.....	1-7
1.6.6 Fastenings.....	1-7
1.6.7 Bulletin Boards.....	1-7
1.6.8 Chairs.....	1-7
1.6.9 Arrangement and Location.....	1-7
1.7 COLOR.....	1-7
1.8 PERSONNEL ACCESS CLEARANCES AND ACCESS SAFETY.....	1-8
1.8.1 Overhead Clearance.....	1-8
1.8.2 Walking Area Clearances.....	1-8
1.8.3 Access Safety.....	1-8
1.9 FRESH WATER.....	1-8
1.9.1 Fresh Water Production and Stowage Capacity.....	1-8
1.9.1.1 Fresh Water Production for Habitability.....	1-8
1.9.1.2 Fresh Water Stowage for Habitability.....	1-8
1.9.2 Water Coolers.....	1-8
1.9.3 Ice Making.....	1-9
1.9.4 Water Heaters.....	1-9
1.9.5 Water Disinfection.....	1-9
1.9.6 Emergency Wash Facilities (EWF).....	1-9
CHAPTER 2 HABITABILITY FACILITIES (ACCOMMODATIONS AND PERSONAL SERVICES)	2-1
2.1 GENERAL.....	2-1
2.1.1 Accommodation Design Margin and Service Life Allowances.....	2-1
2.2 BERTHING SPACES.....	2-1
2.2.1 Berthing Requirements.....	2-1
2.2.2 Personnel Groupings.....	2-1
2.2.3 Sea Cabins.....	2-2
2.2.4 Berths.....	2-2
2.2.4.1 Type.....	2-2
2.2.4.2 Berth Tier.....	2-2
2.2.4.3 Berth Cubicle.....	2-2
2.2.5 Berthing Clearances.....	2-2
2.2.6 Berth Features.....	2-2
2.2.7 Space Considerations.....	2-3
2.2.8 Enlisted Personnel.....	2-3
2.2.8.1 Enlisted Crew and Troops.....	2-3
2.2.8.2 CPOs and SNCOs.....	2-4

Chapter/Paragraph/Title	Page
2.2.8.3 Command Master Chief and Command Sergeant Major.....	2-4
2.2.9 Officers.....	2-4
2.3 STOWAGE FOR PERSONAL GEAR AND EFFECTS.....	2-5
2.3.1 Stowage for Personal Effects.....	2-5
2.3.2 Troop Field Pack and Arms Stowage.....	2-7
2.3.3 Work Clothing Lockers.....	2-7
2.3.4 Aviation Personnel Flight Gear Clothing Lockers.....	2-7
2.4 SANITARY SPACES.....	2-7
2.4.1 General.....	2-7
2.4.2 Cleaning and Maintenance.....	2-8
2.4.3 Heating and Ventilation.....	2-8
2.4.4 Sanitary Facilities for Personal Hygiene, Grooming, and Elimination of Bodily Fluids.....	2-8
2.4.4.1 Sanitary Facilities Serving Berthing Areas.....	2-8
2.4.4.2 Deck WR/WCs Serving General Areas of the Ship.....	2-9
2.4.4.3 Sanitary Facilities Serving Medical and Dental Spaces and Battle Dressing Stations.....	2-10
2.4.4.4 Sanitary Spaces Serving the Brig.....	2-10
2.4.5 Sanitary Requirements in Food Service Spaces.....	2-10
2.4.6 Laundries.....	2-10
2.4.7 Workshops.....	2-10
2.4.8 Cleaning Gear Locker.....	2-11
2.4.9 Major Sanitary Fixtures.....	2-11
2.4.9.1 Lavatories (Washbasins).....	2-11
2.4.9.2 Water Closets (WC or Toilets).....	2-11
2.4.9.3 Showers.....	2-12
2.4.10 Accommodations per Major Fixture.....	2-12
2.4.11 Fittings and Miscellaneous Accessories.....	2-13
2.4.12 Design and Construction Considerations.....	2-13
2.5 FOOD SERVICE SPACES.....	2-14
2.5.1 General.....	2-14
2.5.2 Food Service Equipment.....	2-14
2.5.3 Doors in Food Service Spaces.....	2-14
2.5.4 Messroom Design Requirements.....	2-15
2.5.5 Messroom Furniture Sizes and Clearances.....	2-15
2.5.6 Messroom Outfitting.....	2-15
2.5.7 Clearance in Messrooms.....	2-16
2.5.8 Messroom Seating.....	2-16
2.5.8.1 Crew/Troop Messrooms.....	2-16
2.5.8.2 Officer and CPO/SNCO Messrooms.....	2-16
2.5.9 Galley.....	2-17
2.5.9.1 General.....	2-17
2.5.9.2 Outfitting.....	2-18
2.5.9.3 Potable Water.....	2-18
2.5.9.4 Ice Making Facilities.....	2-18

Chapter/Paragraph/Title	Page
2.5.9.5 Drains.....	2-18
2.5.9.6 Maintenance/Cleaning.....	2-18
2.5.9.7 Galley Dimensional Aspects.....	2-18
2.5.9.8 Dry, Freeze, and Chill Provision Storerooms, Provisions Issue Room, and Meat Thaw Room Supporting Galley.....	2-19
2.5.9.9 Scullery.....	2-19
2.5.9.10 Solid Waste Processing Equipment.....	2-20
2.6 LEISURE AND COMMUNITY.....	2-21
2.6.1 General.....	2-21
2.6.2 Lounge Facilities (Officer Wardrooms, CPO/SNCO, and Crew/Troop Lounge Spaces).....	2-21
2.6.3 Recreational and Physical Fitness Facilities.....	2-21
2.6.3.1 Recreation Space.....	2-21
2.6.3.2 Physical Fitness Facilities.....	2-21
2.6.4 LMRC.....	2-25
2.6.5 Training.....	2-26
2.6.6 Religious Ministry.....	2-26
2.6.7 Audio Visual Television/Audio Systems.....	2-27
2.7 SERVICE SPACES.....	2-27
2.7.1 Barber Shop.....	2-27
2.7.2 Post Office.....	2-28
2.7.3 Ship Store.....	2-28
2.7.4 Vending Machines.....	2-28
2.7.5 Laundry.....	2-29
2.7.5.1 Ship’s Institutional Full Service Laundry.....	2-29
2.7.5.2 Self-Service Laundries.....	2-31
CHAPTER 3 MEDICAL AND DENTAL SPACES.....	3-1
3.1 GENERAL.....	3-1
3.2 SHIP TYPES.....	3-1
3.3 GENERAL REQUIREMENTS FOR SPACES.....	3-1
3.3.1 Location.....	3-1
3.3.2 Water System.....	3-1
3.3.3 Dimensional Aspects.....	3-1
3.3.4 Medical and Dental Space Arrangements.....	3-1
3.4 DRAWINGS AND DATA TO BE SUBMITTED.....	3-2
3.5 TESTING.....	3-2
3.6 REQUIRED MEDICAL SPACES.....	3-2
3.7 OUTFITTING OF MEDICAL SPACES.....	3-6
3.7.1 General Outfitting for Spaces.....	3-6
3.7.2 Medical Beds and Berths.....	3-7
3.7.3 Exam and Operating Tables.....	3-7
3.8 REQUIRED DENTAL SPACES.....	3-7
3.9 OUTFITTING OF DENTAL SPACES.....	3-8
3.10 DISTRIBUTED MEDICAL EQUIPMENT REQUIREMENTS.....	3-9

Chapter/Paragraph/Title	Page
3.10.1 First Aid Boxes (FAB).....	3-9
3.10.2 Portable Medical Lockers (PMLs)/Mass Casualty Boxes (MCBs).	3-9
3.10.3 Stretchers/Litters.....	3-9
3.10.4 Gun Bags.	3-10
3.10.5 Cylinder, Oxygen, Size D.....	3-10
3.10.6 Cylinder, Oxygen, Size H.....	3-10
CHAPTER 4 HABITABILITY STOREROOMS.....	4-1
4.1 GENERAL.....	4-1
PART II, DESIGN PRACTICES.....	II
CHAPTER 1 GENERAL DESIGN GUIDANCE.....	1-1
1.1 GOAL.....	1-1
1.2 STANDARDS.....	1-1
1.3 MANNING.....	1-1
1.4 DESIGN AND DEVELOPMENT OF HABITABILITY FACILITIES.....	1-1
1.4.1 Habitability Design Development Process.....	1-1
1.4.2 Feasibility Study Phase.....	1-2
1.4.3 Preliminary Design Phase.....	1-2
1.4.4 Contract Design.....	1-2
1.5 COMPARTMENT DESIGN.....	1-3
1.5.1 Location.....	1-3
1.5.1.1 Noise.....	1-3
1.5.1.2 Vibration.....	1-3
1.5.1.3 Motion.....	1-4
1.5.1.4 Access.....	1-4
1.5.1.5 Proximity to Propulsion Plants in Nuclear Powered Warships.....	1-4
1.5.1.6 Tanks.....	1-4
1.5.2 Boundaries.....	1-4
1.5.2.1 Bulkheads.....	1-4
1.5.2.2 Shell and Deckhouse.....	1-4
1.5.2.3 Overhead.....	1-4
1.5.2.4 Deck.....	1-4
1.5.3 Access.....	1-4
1.5.3.1 Door.....	1-4
1.5.3.2 Scuttle.....	1-4
1.5.3.3 Hatch.....	1-5
1.5.3.4 Manhole.....	1-5
1.5.4 Scantlings.....	1-5
1.5.4.1 Stiffeners.....	1-5
1.5.4.2 Stanchions.....	1-5
1.5.4.3 Longitudinals and Stringers.....	1-5
1.5.4.4 Web Frames.....	1-5
1.5.4.5 Miscellaneous.....	1-5
1.5.5 Distributive Systems.....	1-5

Chapter/Paragraph/Title	Page
1.5.5.1 Ventilation.....	1-5
1.5.5.2 Piping.....	1-5
1.5.5.3 Wireways.....	1-5
1.5.6 Human Engineering.....	1-5
1.5.6.1 Personnel.....	1-5
1.5.6.2 Standardization.....	1-5
1.5.6.3 Life Cycle.....	1-6
1.6 EQUIPMENT DESIGN.....	1-6
1.6.1 General.....	1-6
1.6.2 Ship Motion Requirements.....	1-7
1.6.2.1 Foundation.....	1-7
1.6.2.2 Inclination.....	1-8
1.6.2.3 Positive Latching Mechanisms.....	1-8
1.6.2.4 Battens.....	1-8
1.6.2.5 External Design.....	1-8
1.6.3 Ship Integration Requirements.....	1-8
1.6.3.1 Size and Weight.....	1-8
1.6.3.2 Hatchable.....	1-8
1.6.3.3 Front Access.....	1-8
1.6.3.4 Electrical Power.....	1-8
1.6.3.5 Electromagnetic Interference (EMI).....	1-8
1.6.3.6 Heat, Noise, and Vibration.....	1-8
1.6.4 Shipboard Environmental Requirements.....	1-8
1.6.4.1 Vibration.....	1-8
1.6.4.2 Varying Service Conditions.....	1-8
1.6.4.3 Temperature.....	1-8
1.6.4.4 Water Spray.....	1-8
1.6.4.5 Corrosion.....	1-8
1.6.4.6 Shock.....	1-8
1.6.4.7 Security.....	1-8
1.6.5 Additional Safety Requirements.....	1-9
1.6.5.1 Protective Shields.....	1-9
1.6.5.2 Safety Interlocks.....	1-9
1.6.5.3 Brittle Materials.....	1-9
1.6.5.4 Passive Fire Safety.....	1-9
1.6.5.5 Hazardous Materials.....	1-9
1.7 COLOR SCHEMES.....	1-9
1.7.1 Purpose.....	1-9
1.7.2 Components.....	1-9
1.7.3 Numbers.....	1-9
1.7.3.1 Definition of Change.....	1-9
1.7.3.2 Multiple Color Schemes.....	1-9
1.7.4 Objectives.....	1-9

Chapter/Paragraph/Title	Page
1.7.5 Color Selection Requirements	1-10
1.7.5.1 Visibility	1-10
1.7.5.2 Maintenance	1-10
1.7.5.3 Numbers of Colors	1-10
1.7.6 Applications Guidelines.....	1-10
1.7.6.1 Bulkheads	1-11
1.7.6.2 Overheads	1-11
1.7.6.3 Deck	1-11
1.7.6.4 Built-In Cabinets.....	1-11
1.7.6.5 Furniture	1-11
1.7.6.6 Upholstery.....	1-11
1.7.6.7 Curtains and Drapes.....	1-11
1.7.6.8 Accessories	1-11
1.7.6.9 Hardware and Trim	1-11
CHAPTER 2 OFFICER LIVING SPACES	2-1
2.1 GENERAL	2-1
2.1.1 Number	2-1
2.1.2 Location	2-1
2.1.3 Types of Officers	2-1
2.1.4 Types of Living Spaces.....	2-1
2.1.4.1 Sea Cabin	2-1
2.1.4.2 Cabin and Stateroom.....	2-1
2.1.4.3 Single Stateroom	2-1
2.1.4.4 Double Stateroom	2-1
2.1.4.5 Triple Stateroom	2-1
2.1.4.6 Bunkroom (Maximum of Six Junior Officers).....	2-1
2.1.4.7 Transient Berthing	2-1
2.1.4.8 Surge Berthing	2-1
2.1.5 Functions of Living Spaces.....	2-2
2.1.6 Related Spaces	2-2
2.2 OUTFIT AND FURNISHINGS	2-2
2.2.1 Sleeping Surfaces.....	2-2
2.2.2 Modular Furniture Units	2-2
2.2.3 Modular Furniture Groups	2-3
2.2.4 Accessory Furnishings.....	2-3
2.3 ARRANGEMENT PRACTICES	2-3
2.3.1 Single Staterooms for Small Ships	2-3
2.3.1.1 Berth	2-3
2.3.1.2 Lavatory.....	2-3
2.3.1.3 Secretary Bureau	2-4
2.3.1.4 Long Wardrobe	2-4
2.3.1.5 Bookrack.....	2-4
2.3.1.6 Access	2-4

Chapter/Paragraph/Title	Page
2.3.1.7 Furniture Clearance.....	2-4
2.3.1.8 Sheathing and Carpeting.....	2-4
2.3.2 Double Staterooms for Small Ships (see Part II, Figure 2-2, Modular Group 7).....	2-4
2.3.3 Single Staterooms for Mid-Size and Large Ships (see Part II, Figure 2-3, Modular Group 1).....	2-4
2.3.4 Double Staterooms for Mid-Size and Large Ships (see Part II, Figure 2-3, Modular Group 3).....	2-4
2.3.5 Triple Staterooms for All Ships (see Part II, Figure 2-4, Modular Group 7 Modified).....	2-4
2.3.6 Bunkrooms (Ship’s Company) (see Part II, Figure 2-4, Modular Group 7).....	2-4
2.3.6.1 Furniture.....	2-4
2.3.6.2 Functional Area Separation.....	2-4
2.3.7 Troop Officer Bunkrooms (see Part II, Figure 2-5, Modular Group 7).....	2-4
2.3.8 Department Head Staterooms for Mid-Size and Large Ships (see Part II, Figure 2-6, Modular Group 2).....	2-4
2.3.8.1 Desk.....	2-4
2.3.8.2 Transom Berth.....	2-5
2.3.9 CO Stateroom/XO Stateroom for Small Ships (see Part II, Figure 2-6, Modular Group 2).....	2-5
2.3.9.1 Special Functions.....	2-5
2.3.9.2 Location.....	2-5
2.3.10 XO, Squadron, and Unit Commander Living Spaces on Large Ships (see Part II, Figure 2-7, Modular Group 2).....	2-5
2.3.10.1 Living Spaces.....	2-5
2.3.10.2 Stateroom.....	2-5
2.3.10.3 Cabin.....	2-5
2.3.11 CO Sea Cabin (see Part II, Figure 2-6).....	2-5
2.3.12 CO/Flag Living Spaces on Large Ships (see Part II, Figure 2-8, Modular Group 5).....	2-5
2.3.12.1 Living Spaces.....	2-5
2.3.12.2 Stateroom.....	2-5
2.3.12.3 Cabin.....	2-5
CHAPTER 3 CHIEF PETTY OFFICER (CPO) AND SENIOR NONCOMMISSIONED OFFICER (SNCO)	
LIVING SPACES	3-1
3.1 GENERAL.....	3-1
3.1.1 Ratings.....	3-1
3.1.2 Number.....	3-1
3.1.3 Location.....	3-1
3.1.3.1 Living Spaces.....	3-1
3.1.3.2 Types of Living Spaces.....	3-1
3.1.3.3 Access.....	3-1
3.1.4 Functions.....	3-1
3.1.5 Related Spaces.....	3-1
3.2 OUTFIT AND FURNISHINGS.....	3-1
3.2.1 Berth Cubicles.....	3-1
3.2.1.1 Two-High Berth Cubicles (see Part II, Figure 3-1).....	3-2
3.2.1.2 Three-High Berth Cubicles for CPOs and SNCOs and for Transient CPOs and SNCOs (see Part II, Figure 3-2).....	3-2
3.2.2 Accessory Furnishings.....	3-3

Chapter/Paragraph/Title	Page
3.3 ARRANGEMENT PRACTICES.....	3-3
3.3.1 CPO Living Spaces (see Part II, Figure 3-3).....	3-3
3.3.1.1 Cubicles.....	3-3
3.3.1.2 Berths.....	3-3
3.3.1.3 Shell.....	3-3
3.3.1.4 Installation.....	3-3
3.3.1.5 Accessories.....	3-3
3.3.1.6 Sanitary Space.....	3-3
3.3.1.7 Fan Coil Assemblies.....	3-3
3.3.1.8 Accesses.....	3-3
3.3.1.9 Sheathing.....	3-3
3.3.2 Command Master Chief Stateroom (see Part II, Figure 3-3).....	3-3
3.3.3 SNCO Living Spaces (see Part II, Figure 3-3).....	3-4
3.3.3.1 Surge SNCO Living Spaces.....	3-4
3.3.4 Command Sergeant Major Stateroom (see Part II, Figure 3-3).....	3-4
CHAPTER 4 CREW AND TROOP LIVING SPACES.....	4-1
4.1 GENERAL.....	4-1
4.1.1 Ratings.....	4-1
4.1.2 Number.....	4-1
4.1.3 Distribution.....	4-1
4.1.4 Location.....	4-1
4.1.4.1 Crew and Troop Living Spaces.....	4-1
4.1.4.2 Types of Living Spaces.....	4-1
4.1.4.3 Access.....	4-1
4.1.5 Functions.....	4-1
4.1.6 Related Spaces.....	4-1
4.2 OUTFIT AND FURNISHINGS.....	4-2
4.2.1 Berth Cubicles (see Part II, Figures 4-1 and 4-2).....	4-2
4.2.1.1 Berths.....	4-2
4.2.1.2 Lockers (for Locker Type Berth).....	4-2
4.2.1.3 Lockers (for Pan Type Berth).....	4-2
4.2.2 Accessory Furnishings.....	4-2
4.3 ARRANGEMENT PRACTICES.....	4-3
4.3.1 Crew Living Spaces (see Part II, Figure 4-2).....	4-3
4.3.1.1 Cubicles.....	4-3
4.3.1.2 Berths.....	4-3
4.3.1.3 Shell.....	4-3
4.3.1.4 Soiled Laundry.....	4-3
4.3.1.5 Installation.....	4-3
4.3.1.6 Accessories.....	4-3
4.3.1.7 Sanitary Space.....	4-3
4.3.1.8 Fan Coil Assemblies.....	4-3
4.3.1.9 Accesses.....	4-3

Chapter/Paragraph/Title	Page
4.3.1.10 Sheathing.....	4-3
4.3.2 Troop Living Spaces (see Part II, Figure 4-3).....	4-4
4.3.2.1 Surge Troop Living Spaces (see Part II, Figure 4-4).....	4-4
4.3.2.2 Surge Troop Living Spaces in Ships With High Deck Heights.	4-4
CHAPTER 5 SANITARY SPACES.....	5-1
5.1 GENERAL.....	5-1
5.1.1 Distribution.....	5-1
5.1.2 Types.....	5-1
5.2 OUTFIT AND FURNISHINGS.....	5-1
5.2.1 Water Closet (WC or Toilet, see Part II, Figure 5-1).....	5-1
5.2.1.1 Design.....	5-1
5.2.1.2 Piping.....	5-1
5.2.1.3 Orientation.....	5-1
5.2.1.4 Partitions.....	5-1
5.2.1.5 WC Door.....	5-2
5.2.1.6 Accessories.....	5-2
5.2.2 Shower (see Part II, Figure 5-2).....	5-2
5.2.2.1 Piping.....	5-2
5.2.2.2 Orientation.....	5-2
5.2.2.3 Partitions.....	5-2
5.2.2.4 Accessories.....	5-2
5.2.2.5 Combination Shower and Decontamination Station.....	5-2
5.2.3 Lavatory (see Part II, Figure 5-3).....	5-2
5.2.3.1 Design.....	5-2
5.2.3.2 Piping.....	5-2
5.2.3.3 Orientation.....	5-2
5.2.3.4 Accessories.....	5-3
5.3 ARRANGEMENT PRACTICES.....	5-3
5.3.1 WR, WC, and SH Facilities (see Part II, Figure 5-4).....	5-3
5.3.1.1 Sanitary Space Grouping.....	5-3
5.3.1.2 Functional Area Grouping.....	5-3
5.3.1.3 Access and Arrangement.....	5-3
5.3.1.4 Clearances, Spacing, and Orientation.....	5-3
5.3.1.5 Bulkhead Separation.....	5-3
5.3.1.6 Cleaning and Maintenance.....	5-3
5.3.1.7 Shower Partitions and Bulkheads.....	5-3
5.3.1.8 Shower Drying Area Door.....	5-3
5.3.1.9 Shell/Weather Bulkhead Constraint.....	5-3
5.3.1.10 Cleaning Gear Locker.....	5-4
5.3.1.11 Water Heaters.....	5-4
5.3.1.12 Towel Hooks and Racks.....	5-4
5.3.1.13 Ventilation.....	5-4
5.3.1.14 Heating.....	5-4

Chapter/Paragraph/Title	Page
5.3.1.15 Deck Covering, Coamings, and Drains.....	5-4
5.3.2 Deck WR/WC (see Part II, Figure 5-5).	5-4
5.3.3 Ward WR, WC, and SH.....	5-4
5.3.4 Bath (see Part II, Figure 5-6).	5-4
5.3.5 Private T/S.	5-4
5.3.6 Semi-Private T/S (see Part II, Figure 5-7).	5-4
5.3.7 Quiet Room Bath.	5-4
5.3.8 Brig.....	5-4
CHAPTER 6 LEISURE AND COMMUNITY SPACES	6-1
6.1 GENERAL.	6-1
6.1.1 Purpose.	6-1
6.1.2 Types.	6-1
6.2 CHAPEL.	6-1
6.2.1 Function.	6-1
6.2.2 Outfit and Furnishings.	6-1
6.2.3 Arrangement Practices (see Part II, Figure 6-1).	6-2
6.2.3.1 Fully Mobile Arrangement.	6-2
6.2.3.2 Fixed Chancel Arrangement.	6-2
6.3 LMRC.	6-2
6.3.1 Function.	6-2
6.3.2 Outfit and Furnishings.	6-2
6.3.3 Arrangement Practices (see Part II, Figure 6-2).	6-2
6.3.3.1 Librarian’s Station.	6-2
6.3.3.2 Book Stacks Area.....	6-2
6.3.3.3 Study Area.	6-2
6.3.3.4 Reading Area.	6-2
6.4 PHYSICAL FITNESS SPACE.	6-2
6.4.1 Function.	6-2
6.4.2 Outfit and Furnishings.	6-2
6.4.3 Arrangement Practices.	6-2
6.4.3.1 Size.	6-3
6.4.3.2 Location.	6-3
6.4.3.3 Mirrors.	6-3
6.4.3.4 Equipment Selection.	6-3
6.5 LOUNGE.	6-3
6.5.1 Function.	6-3
6.5.2 Outfit and Furnishings.	6-3
6.5.3 Arrangement Practices (see Part II, Figure 6-3).	6-3
6.5.3.1 Officer Wardroom Lounge.	6-3
6.5.3.2 CPO/SNCO Lounge.....	6-3
6.5.3.3 Crew/Troop Lounge.....	6-3
6.6 RECREATION SPACE.	6-3
6.6.1 Function.	6-3

Chapter/Paragraph/Title	Page
6.6.2 Outfit and Furnishings.	6-3
6.6.3 Arrangement Practices (see Part II, Figure 6-3).....	6-3
6.6.3.1 Alternate Functions.	6-3
6.7 TRAINING.	6-4
6.7.1 Function.	6-4
6.7.2 Outfit and Furnishings.	6-4
6.7.3 Arrangement Practices.	6-4
6.7.3.1 Instruction Area.....	6-4
6.7.3.2 Seating Area.	6-4
CHAPTER 7 FOOD SERVICE SPACES.....	7-1
7.1 GENERAL.	7-1
7.1.1 Galley Type – Centralized Galley (see Part II, Figure 7-1).	7-2
7.1.2 Type of Service.	7-2
7.1.3 Location.	7-2
7.2 OUTFIT AND FURNISHINGS.	7-2
7.2.1 Food Service Spaces.	7-2
7.2.2 Messroom.....	7-2
7.2.2.1 Officer Messroom.	7-2
7.2.2.2 CPO Messroom.	7-2
7.2.2.3 Crew Messroom.	7-2
7.3 ARRANGEMENT PRACTICES.	7-2
7.3.1 Food Preparation Spaces.....	7-2
7.3.2 Messrooms.	7-2
7.4 DESIGN PARAMETERS FOR ESTABLISHING FOOD SERVICE EQUIPMENT REQUIREMENTS.	7-3
7.4.1 Galley Equipment.	7-3
7.4.1.1 Refrigeration for Chilled Foods, Leftovers, and Thawing Meat.	7-3
7.4.1.2 Frozen Food Cabinet.....	7-3
7.4.1.3 Meat Thaw.	7-3
7.4.1.4 Combination Ovens.....	7-3
7.4.1.5 Steam Jacketed Kettles.....	7-4
7.4.1.6 Skittles Cooker.	7-4
7.4.1.7 Holding Cabinet.	7-4
7.4.1.8 Serving Line.	7-4
7.4.2 Trash Holding.	7-5
7.4.3 Messroom Equipment.	7-5
7.4.3.1 Mess Gear.	7-5
7.4.3.2 Hot Food Counters.	7-5
7.4.3.3 Refrigerated Salad Bar.	7-5
7.4.3.4 Refrigerated Milk Dispenser.	7-5
7.4.3.5 Refrigerated Milk Storage Stand.	7-5
7.4.3.6 Refrigerated Beverage Dispenser.....	7-5
7.4.3.7 Refrigerated Ice Dispenser.	7-6
7.4.3.8 Ice Cream Making Equipment.	7-6

Chapter/Paragraph/Title	Page
7.4.3.9 Beverage Service Stand.....	7-6
7.4.3.10 Coffee Urn.....	7-6
7.4.4 Bakery.....	7-6
7.4.4.1 Bakery Equipment.....	7-6
7.4.5 Provision Issue Room.....	7-7
7.4.6 Vegetable Preparation Area.....	7-7
7.4.6.1 Vegetable Preparation Equipment.....	7-7
7.4.7 Utensil Wash Room Equipment.....	7-7
7.4.7.1 Dresser.....	7-7
7.4.7.2 Sanitize Sink Heater.....	7-7
7.4.7.3 Food Waste Disposer (FWD).....	7-7
7.4.7.4 Pot Scrubber/Utensil Washer.....	7-7
7.4.7.5 Utensil Storage Racks.....	7-7
7.4.8 Scullery Equipment.....	7-7
7.4.8.1 Dishwashing Machines.....	7-7
7.4.8.2 Dresser (Fabricated).....	7-8
7.4.8.3 FWD.....	7-8
7.4.8.4 Roller Conveyor.....	7-8
7.4.8.5 Storage.....	7-8
7.4.8.6 Mess Gear Dispensers for 65 Percent of Crew Size.....	7-8
7.4.9 Flag/CO Galley Equipment.....	7-8
7.4.9.1 Combination Convection-Steam Oven.....	7-8
7.4.9.2 Griddle.....	7-8
7.4.9.3 Steam Jacketed Kettles.....	7-8
7.4.9.4 Refrigerator/Freezer.....	7-8
7.4.9.5 Mixer.....	7-8
7.4.9.6 Ice Maker/Dispenser.....	7-8
7.4.9.7 Beverage Dispenser.....	7-8
7.4.9.8 Coffee Maker.....	7-8
7.4.9.9 Dishwashing Machine.....	7-8
7.4.9.10 Toaster.....	7-8
7.4.9.11 Waffle Iron.....	7-8
CHAPTER 8 SERVICE SPACES.....	8-1
8.1 GENERAL.....	8-1
8.2 BARBER SHOP.....	8-1
8.2.1 Location.....	8-1
8.2.2 Operation.....	8-1
8.2.3 Outfit and Furnishings.....	8-1
8.2.4 Arrangement Practices (see Part II, Figure 8-1).....	8-2
8.2.4.1 Barber Chairs.....	8-2
8.2.4.2 Counters.....	8-2
8.3 SHIP STORE.....	8-3
8.3.1 Location.....	8-3

Chapter/Paragraph/Title	Page
8.3.2 Operation.....	8-3
8.3.3 Outfit and Furnishings.	8-3
8.3.3.1 Walk-In Ship Store.....	8-3
8.3.3.2 Window-Service Ship Store.	8-3
8.3.4 Arrangement Practices.	8-4
8.3.4.1 Walk-In Ship Store (see Part II, Figure 8-2).	8-4
8.3.4.2 Window-Service Ship Store.....	8-4
8.4 VENDING MACHINE AREAS.	8-5
8.4.1 Location.	8-5
8.4.2 Operation.....	8-5
8.4.3 Arrangement Practices.	8-5
8.4.3.1 Groups.....	8-5
8.4.3.2 Stowage.....	8-5
8.4.3.3 Clearance.....	8-5
8.4.3.4 Trash.	8-5
8.5 BRIG.....	8-5
8.5.1 Location.	8-5
8.5.2 Operation.....	8-5
8.5.3 Outfit and Furnishings.	8-5
8.5.4 Arrangement Practices.	8-5
8.6 POST OFFICE.....	8-5
8.6.1 Location.	8-5
8.6.2 Operation.....	8-5
8.6.3 Outfit and Furnishings/Arrangement Practices.	8-6
CHAPTER 9 LAUNDRY AND FINISHING SPACES	9-1
9.1 GENERAL.	9-1
9.2 SHIP'S INSTITUTIONAL FULL SERVICE LAUNDRY.....	9-1
9.2.1 Location.	9-1
9.2.2 Equipment Selection.	9-1
9.2.2.1 Laundry Equipment.....	9-1
9.2.3 Accessory Equipment.	9-1
9.2.4 Arrangement Practices.	9-1
9.2.4.1 Orientation.	9-1
9.2.4.2 Wash Area.....	9-2
9.2.4.3 Coaming.....	9-2
9.2.4.4 Wash Area Accessories.....	9-2
9.2.4.5 Water Heaters.....	9-2
9.2.4.6 Dryer Side Clearance.	9-2
9.2.4.7 Utility Presses.	9-2
9.2.4.8 Spray Gun.	9-2
9.2.4.9 Work Tables.....	9-2
9.2.4.10 Jack Rods.	9-2
9.2.4.11 Receiving and Issue Area.....	9-2

Chapter/Paragraph/Title	Page
9.2.4.12 Customer Service.....	9-2
9.2.4.13 Finished Garment Stowage.....	9-2
9.2.4.14 Drinking Fountain.....	9-2
9.2.4.15 Laundry Basket Clearance.....	9-2
9.2.4.16 Ready Service Stores.....	9-2
9.3 SELF-SERVICE LAUNDRY.....	9-3
9.3.1 Location.....	9-3
9.3.2 Equipment Selection.....	9-3
9.3.3 Arrangement Practices.....	9-3
APPENDIX A APPLICABLE DOCUMENTS	A-1
A.1 GENERAL.....	A-1
A.2 GOVERNMENT DOCUMENTS.....	A-1
A.2.1 Specifications, Standards, and Handbooks.....	A-1
A.2.2 Other Government Documents, Drawings, and Publications.....	A-2
A.3 NON-GOVERNMENT PUBLICATIONS.....	A-5
APPENDIX B DEFINITIONS.....	B-1
B.1 ACCOMMODATIONS.....	B-1
B.2 CHIEF PETTY OFFICER (CPO)/SENIOR NONCOMMISSIONED OFFICER (SNCO).....	B-1
B.3 CREW/TROOP.....	B-1
B.4 ENLISTED PERSONNEL.....	B-1
B.5 EXISTING SHIPS.....	B-1
B.6 LIGHT-TIGHT.....	B-1
B.7 NAVY STANDARD CORE MENU (NSCM).....	B-1
B.8 NEW SHIP DESIGNS.....	B-1
B.9 SHIPS COMPANY.....	B-1
B.10 SURGE.....	B-1
B.11 TRANSIENTS.....	B-1

LIST OF FIGURES

Figure No. and Title	Page
Part I	
Figure 2-1. Community Sanitary Space Minimum Clearance Requirements.	2-9
Part II	
Figure 2-1. Modular Furniture Groups.....	2-6
Figure 2-2. Typical Single and Double Stateroom Arrangements.	2-7
Figure 2-3. Typical Single and Double Stateroom Arrangements.	2-8
Figure 2-4. Typical Triple Stateroom and Bunkroom Arrangements.	2-9
Figure 2-5. Typical Troop Officer Bunkroom Arrangements.....	2-10
Figure 2-6. Typical Senior Officer Living Spaces.	2-11
Figure 2-7. Typical Executive Officer, Squadron, and Unit Commander Living Spaces.	2-12
Figure 2-8. Typical CO/Flag Living Spaces.	2-13
Figure 3-1. CPO Berthing – Two-High Typical Four-Person Cubicle.	3-5
Figure 3-2. CPO or SNCO Berthing – Three-High Typical Six-Person Cubicle.....	3-6
Figure 3-3. Typical CPO and SNCO Living Spaces.....	3-7
Figure 4-1. Enlisted Crew or Troop Berthing – Three-High Typical Six-Person Cubicle.....	4-5
Figure 4-2. Typical Crew Living Space.....	4-6
Figure 4-3. Typical Troop Living Space.....	4-7
Figure 4-4. Typical Multi-Purpose Area Troop Recreation/Surge Berthing.....	4-8
Figure 5-1. Water Closet and Partition.	5-5
Figure 5-2. Shower and Partition.	5-6
Figure 5-3. Countertop Lavatory.	5-7
Figure 5-4. Typical Community Sanitary Space.....	5-8
Figure 5-5. Typical Deck WR/WC.	5-9
Figure 5-6. Typical Bath.	5-9
Figure 5-7. Semi-Private T/S.	5-10
Figure 6-1. Typical Chapel.	6-5
Figure 6-2. Typical LMRC.	6-6
Figure 6-3. Typical Lounge and Recreation Seating Groups.	6-7
Figure 7-1. Centralized Galley Concept.....	7-9
Figure 7-2. Typical Crew Messroom.	7-10
Figure 8-1. Typical Barber Shop.....	8-7
Figure 8-2. Typical Walk-in Ship Store.....	8-8
Figure 8-3. Typical Window-Service Ship Store.....	8-9
Figure 9-1. Typical Laundry.....	9-4

LIST OF TABLES

Table No. and Title	Page
Part I	
Table 1-1. Compartment Treatment Plan.	1-3
Table 1-2. Compartment Illumination Levels.....	1-4
Table 1-3. Water Cooler Requirements for Living and Messing Spaces.	1-8
Table 1-4. Water Cooler Requirements for Spaces Other Than Living and Messing Spaces.....	1-9
Table 2-1. Unobstructed Area in Square Feet per Officer Accommodation. ^{1/}	2-5
Table 2-2. Stowage per Accommodation.....	2-6
Table 2-3. Number of Accommodations per Fixture for Community Sanitary Spaces. ^{1/}	2-12
Table 2-4. Fittings and Miscellaneous Accessories for Sanitary Spaces.	2-13
Table 2-5. Crew/Troop Mess Seats.....	2-16
Table 2-6. Officer and CPO/SNCO Mess Seats.	2-17
Table 2-7. LMRC Minimum Space Size Requirements ^{1/}	2-26
Table 2-8. LMRC Equipment Quantities.....	2-26
Table 3-1. Medical Space Requirements for Naval Vessels.....	3-3
Table 3-2. Beds and Berths.....	3-7
Table 3-3. Dental Space Requirements for Naval Vessels.	3-8
Part II	
Table 1-1. Habitability Design Products by Design Stage.....	1-3
Table 1-2. Commercial and Navy Habitability Equipment Differences.	1-7
Table 2-1. Modular Furniture Units (see Figure 2-1).	2-2
Table 2-2. Modular Furniture Groups.....	2-3
Table 7-1. Food Service Spaces. ^{1/}	7-1
Table 8-1. Officer Barber Shop Outfit Quantities.	8-1
Table 8-2. Enlisted Personnel Outfit Quantities.	8-2
Table 8-3. Walk-In Ship Store.....	8-3
Table 8-4. Post Office.....	8-6

FOREWORD

This technical manual provides detailed shipboard habitability design criteria and practices for developing specifications and drawings for new ship designs, and modifications to existing ships. This manual consists of two parts:

Part I provides design criteria requirements of shipboard habitability facilities and Part II provides guidance and rationale for the design of habitability facilities supporting Part I.

The design criteria portion (Part I) includes requirements for medical and dental spaces, offices, and habitability storerooms, but does not include any guidance or supporting design rationale for them in the design practices portion (Part II).

NAVY DISTANCE SUPPORT (DS) CUSTOMER ASSISTANCE CONTACT INFORMATION

Fleet users of this technical manual may request NAVY 311 assistance. NAVY 311 is the Fleet's single point of entry for technical and logistics support whenever routine sources of support are unavailable or are not readily identifiable. NAVY 311 is operated via the Global Distance Support Community (GDSC) of geographically dispersed, centrally coordinated, Tier 1/2 call centers that function on a 24/7 basis. Point of entry options:

Phone: 1-855-NAVY311 (1-855-628-9311)/DSN 510-NAVY311 (510-628-9311)

Navy Distance Support/NAVY 311 Web: <http://www.navy311.navy.mil/> (unclassified) or <https://www.navy311.navy.smil.mil/> (classified). (Provides program information and links to an online Support Request Form and Support Request Status, Live CHAT with a Call Center Rep, Knowledge Base Searching, etc.)

Email: Navy311@navy.mil or Navy311@navy.smil.mil

TMDER INSTRUCTIONS

Ships, training activities, supply points, depots, Naval Shipyards and Supervisors of Shipbuilding are requested to arrange for the maximum practical use and evaluation of NAVSEA and SPAWAR technical manuals (TMs). All errors, omissions, discrepancies, and suggestions for improvement to NAVSEA and SPAWAR TMs shall be submitted as a Technical Manual Deficiency/Evaluation Report (TMDER). All feedback comments shall be thoroughly investigated and originators will be advised of action resulting there from.

The NAVSEA/SPAWAR Technical Manual Deficiency/Evaluation Report form, NAVSEA 4160/1 is included at the back of the TM.

The following methods are available for generation and submission of TMDERs against unclassified TMs:

For those with a Technical Data Management Information System (TDMIS) account, the most expedient and preferred method of TMDER generation and submission is via the TDMIS website at: <https://mercury.tdmis.navy.mil/>.

For those without a TDMIS account, generate and submit TMDER via the Naval Systems Data Support Activity (NSDSA) website at: https://mercury.tdmis.navy.mil/def_external/pubsearch.cfm. (TDMIS accounts may be requested at the NSDSA website at: <https://nsdsa.nmci.navy.mil/>, by submitting a Customer Service Request (CSR).)

When internet access is not available, submit TMDER via hardcopy to:

COMMANDER NAVAL SURFACE WARFARE CENTER
 NAVAL SYSTEMS DATA SUPPORT ACTIVITY
 4363 MISSILE WAY
 ATTN: CODE 310 BLDG 1389 TMDERS
 PORT HUENEME, CA 93043-4307

Additional copies of the TMDER form may also be downloaded from the Naval Systems Data Support Activity (NSDSA) website at: <https://nsdsa.nmci.navy.mil/>, by clicking on the blue tab labeled "Reference Docs/Forms".

TMDERs against classified/restricted TMs (includes all NOFORN) must be submitted using the hardcopy method cited above.

Urgent priority TM deficiencies shall be reported by Naval message with transmission to Port Hueneme Division, Naval Surface Warfare Center (Code 310), Port Hueneme, CA. Local message handling procedures shall be used. The message shall identify each TM deficiency by TM identification number and title. This method shall be used in those instances where a TM deficiency constitutes an urgent problem, (i.e., involves a condition, which if not corrected, could result in injury to personnel, damage to the equipment, or jeopardy to the safety or success of the mission).

Complete instructions for TMDER generation and submission are detailed on the NSDSA website at: <https://nsdsa.nmci.navy.mil/>, by clicking on the blue tab labeled "TMDER/ACN" and then clicking on the gray button labeled "TMDERS".

INTRODUCTION

This manual is invoked as reference (a) by OPNAVINST 9640.1, which stipulates the Chief of Naval Operations shipboard habitability program policy, and procedures and responsibilities for implementation. This manual contains two parts, as well as Applicable Documents (Appendix A), and Definitions (Appendix B). Part I consists of design criteria and Part II consists of design practices. When the design section Part II includes the word “shall,” it is a requirement.

SCOPE.

This manual contains detailed shipboard habitability design criteria and practices for developing specifications and drawings for new ship designs, and modifications to existing ships. When modifications are made to existing ships, every effort shall be made to achieve the habitability design criteria and practices as defined herein, where practicable. However, when modifications to existing ships cannot meet the habitability design criteria and practices herein, such modifications shall be no less than those invoked for the original design or improvements already incorporated into the design. This manual covers the design of habitability facilities, including living (berthing), sanitary, leisure and community, and service spaces, such as food service, and medical/dental spaces supporting a mixed gender crew. It also covers general human factors requirements for manned shipboard spaces, including lighting, heating, ventilation, air conditioning, noise, and vibration. These systems are also discussed in other design manuals, as noted in Appendix A.

PURPOSE.

The purpose of this manual is to implement the provisions of OPNAVINST 9640.1 by establishing U.S. Navy shipboard habitability design criteria and practices, which will ensure unit mission readiness and provide an acceptable level of quality of life for sailors, marines, and other detachments.

APPLICABILITY.

This manual applies to U.S. Navy surface ships, both for new ship designs and for existing in-service ships that require accommodations for personnel living onboard during underway and in-port periods, which require habitability facilities and environmental controls to support their needs. Habitability standards contained herein shall apply to these ships, as required by OPNAVINST 9640.1. For small or specialized naval vessel designs that require only short underway trips of a few days or less, the cognizant Ship Design Manager (SDM) may request that their Deputy Warranting Officer (DWO) approve tailoring of applicable criteria and practices. This manual is not applicable to Military Sealift Command Ships (refer to COMSCINST 9330.6).

USING THIS MANUAL.

Overview. In general, Habitability Standards in Part I of this manual specify what shall be provided in a space, and Habitability Practices in Part II of this manual provide guidance for designing an efficient arrangement. This manual assists the user in four ways:

- a. Provides design criteria direction for new ship designs in ship specification development and for ship modernizations.
- b. Identifies design practices which are not found in standards and specifications.
- c. Provides rationale for these practices, which gives the user insight for making trade-offs where design constraints preclude optimum solutions.
- d. Includes examples of arrangements to illustrate efficient designs.

Organization. In the design criteria part of this manual, there are requirements in four chapters (Chapters 1 through 4). In the design practices part of this manual, there is one general chapter (Chapter 1) and eight specific chapters (Chapters 2 through 9). All documents, drawings, and publications referenced herein are listed in Appendix A, Applicable Documents.

General Procedure. Use the following steps to create compartment arrangements. This procedure applies whether a designer is using pencil and paper or computer graphics.

- a. Establish an objective: determine the purpose and need for the proposed arrangement.
- b. Review references: from the applicable references, such as OPNAVINST 9640.1, determine mandatory design requirements.

c. Review compartment configuration: determine the adequacy of compartment location, adjacencies, size, shape, and access. Make necessary adjustments where possible. Depending on design phase, compartment configuration may be contractually or physically locked in. If the configuration is undetermined, create a proposed compartment configuration based on all known design constraints and the space arrangements shown herein.

d. Enter design constraints:

(1) Compartment boundaries: develop a scaled drawing or three-dimensional view of the compartment boundaries based on the best available configuration information, such as Compartment and Access Drawings, Offsets, or General Arrangement Drawings. Note any overhead restrictions on the plan view.

(2) Compartment interferences: indicate to scale on the compartment boundary drawing known accesses, structural scantlings, and mechanical and electrical distributive systems. Use an assumed space (volume) reservation if exact dimensions are not available or undefined. Show equipment maintenance clearances where required. Consider the impact of spaces above, below, and on all sides.

e. Identify equipment: using baseline ship specification, identify all major equipment to be arranged in the compartment. Commercial items specified in the baseline ship specifications should be validated.

f. Develop arrangement: lay out equipment within the compartment in an acceptable arrangement considering design constraints and the guidance found herein. Consider as many valid designs as time permits and select the best. Using scaled templates of the equipment is helpful in the development of the most advantageous arrangement.

g. Evaluate arrangement: review the selected design against its objective, mandatory requirements, and design constraints.

h. Finalize arrangement: finalize the design, add accessories, material list, notes, references, and title block to the compartment arrangement drawing.

PART I, DESIGN CRITERIA

Part I provides design requirements for shipboard habitability facilities.

CHAPTER 1 ENVIRONMENTAL CONTROLS

1.1 GENERAL.

Although the scope of this manual covers requirements for habitability facilities and equipment, environmental considerations are also included that apply to all manned compartments, including habitability facilities and working spaces, as well as, passageways. A compartment is considered “manned” if it is continually occupied by crew members for longer than 20 minutes. All vital spaces, except fan rooms, and electronic cooling equipment rooms, are also considered manned.

Herein, environmental controls include criteria for temperature, humidity, ventilation, noise, lighting, materials, color, passageways, overhead clearances, and potable water. Environmental limits are established to ensure personnel safety, health, and comfort adequate to sustain maximum personnel effectiveness and morale on Navy ships.

1.2 HEATING, VENTILATION, AND AIR CONDITIONING (HVAC).

This section deals with requirements for replenishment air, heat stress, heating, ventilation, and air conditioning. 0938-LP-018-0010 provides design criteria for air distribution, circulation, exhaust, and returns. Normally occupied spaces shall be treated in accordance with current NAVSEA standards regarding allowable temperature or required rate of air exchange. Particular attention shall be paid to medical and dental storerooms in order to ensure that these spaces are located in areas that can maintain proper temperature and humidity to prevent the loss of sensitive and expensive medical and dental supplies. Minimum replenishment with outside air shall be not less than 5 cubic feet per minute per person.

1.2.1 Ventilation.

1.2.1.1 Intakes. Intakes shall be provided to replenish manned spaces with fresh outside air via HVAC systems. These intakes shall be located so as to minimize introduction of contaminated air from sources such as exhausts, stacks, sources of odors and fumes, other areas with hazardous materials, and sea spray.

1.2.1.2 Air Exchanges. Minimum ventilation with outside air shall be in accordance with the requirements noted below. For HVAC systems that employ Variable Air Volume technology, NAVSEA shall approve the air exchange requirements.

- a. Manned spaces: the rate of air exchange for all manned ventilated spaces shall be no less than six complete air changes per hour.
- b. Sanitary spaces: ventilation in all sanitary spaces shall be specifically designed to minimize high humidity, condensation, and odor persistence, including a minimum air exchange rate of 15 changes per hour, and, as a minimum, provision of one exhaust terminal located to service each shower group and water closet (WC) group.
- c. Heat producing spaces: special attention shall be given to high heat producing spaces such as the galley, scullery, and laundry, with design provisions to include exhaust hoods for specific equipment.

1.2.2 Heating.

1.2.2.1 Heating Season. Ships shall have the capability to sustain compartment temperature of at least 65 °F dry bulb (DB) in all living, sanitary, messing, control spaces, and normal working stations. This requirement applies with ambient external conditions as low as 10 °F DB, and seawater temperature of 28 °F, with full complement of personnel on board and normal machinery operating.

1.2.2.2 Heating Sanitary Facilities. Washrooms, baths, and shower areas shall be heated to 75 °F. WCs, when in separate compartments, can be heated to 65 °F.

1.2.2.3 Heating Medical and Dental Facilities. Medical and dental facilities shall be heated to 75 °F.

1.2.2.4 Extensive Cold-Weather Operations. During development of the Initial Capabilities Document (ICD) and Capability Development Document (CDD), considerations shall be made for ships that will operate extensively in cold-weather conditions; the ambient external design temperature shall be reduced to -20 °F DB. Air to normally ventilated spaces in these ships shall be preheated to 10 °F, except where there is a danger of freezing liquids, in which case the minimum preheat temperature shall be 40 °F.

1.2.3 Air Conditioning.

1.2.3.1 Cooling Season. All living, messing, medical/dental, normal working spaces, electronics, and necessary control spaces shall be air conditioned to maintain, as a maximum, 78 °F DB and 65 °F wet bulb (WB). This applies to external ambient conditions as high as 90 °F DB and 81 °F WB, and seawater temperature of 85 °F, with full complement of personnel on board and normal machinery operating. While air conditioning is a design goal for galley, laundry, and ship's store storerooms, for the purpose of crew quality of life, it should be considered a priority for these spaces.

1.2.3.2 Extensive Warm-Weather Operations. During development of the ICD and CDD, considerations shall be made for ships that will operate extensively in tropical conditions; the external ambient design temperature shall be increased to 105 °F DB, 87.5 °F WB, and seawater temperature of 95 °F. Air to normally ventilated spaces in these ships shall be pre-cooled to 90 °F DB.

1.2.4 Heat Stress. In all spaces, the heat stress control requirements contained in OPNAVINST 5100.19 shall be applied. Machinery spaces shall employ spot cooling techniques at watch and work stations to provide adequate degrees of personal health and comfort.

1.2.5 HVAC Terminals in Berthing Spaces. No HVAC terminal shall be located over a berth or berth unit. Terminals shall not discharge towards a berth. Each enlisted berth shall be provided with an individual fan with louvers, unless otherwise provided with built-in ventilation ducting and terminal provided on some Navy ships. Officer berths, when provided with curtains, may be provided with a fan as an option.

1.2.6 Indoor Climate Measurements. Calculations and measurements shall be conducted for manned compartments to ensure the heating and air conditioning systems are designed to support the temperature and humidity levels as specified herein. HVAC systems shall be capable of regulating temperature in the vicinity of the system thermostat to ± 2 °F of required compartment temperature.

1.3 NOISE AND WHOLE BODY VIBRATION.

1.3.1 Noise. OPNAVINST 5100.19 addresses hearing conservation programs and methods to reduce exposure to high noise levels, including steady-state, intermittent, and impact or impulsive type noises, as well as Time Weighted Average (TWA) limits for crew exposure. MIL-STD-1474 provides airborne noise criteria for Navy ships with acceptable compartment noise levels, categorized according to personnel functional requirements under all ship operating conditions. The combination of TWA noise exposure and compartment noise limits shall be factored into the design of a Navy ship in all manned spaces to support the Navy hearing conservation program in high-noise environments. A noise mitigation plan shall be developed and submitted to the Navy for approval to meet the requirements of MIL-STD-1474 in accordance with the following paragraphs.

1.3.1.1 Compartment Sound Levels. Compartment sound levels shall be determined during the design process by factoring in all known shipboard noise and vibration sources that include, but are not limited to, equipment, machinery, engines, HVAC and piping systems, motors, drive shaft, propulsors, fans, blowers, aircraft, vehicles, radio-frequency electromagnetic fields, wave slamming, water, and air turbulence. Means shall be provided to reduce or abate noise levels by means of selecting low source level equipment, acoustic absorptive material, transmission loss treatments at or near the source and/or in manned compartments, vibration isolation techniques, damping treatments, sheathing/joiner improvement, or other noise and vibration abatements techniques in order to meet compartment noise levels and hearing conservation criteria on a system level in accordance with OPNAVINST 5100.19 and MIL-STD-1474.

1.3.1.1.1 Computer Modeling. Use computer modeling based on design guide SNAME T&R Bulletin 3-37, or other commercial tools approved by the Navy, to capture known and projected noise/vibration sources and to identify and optimize acoustic treatments to mitigate the various noise sources. The data shall demonstrate that the mitigation plan will meet compartment noise limits and crew TWA levels in accordance with MIL-STD-1474. Results from computer-based modeling shall be provided to NAVSEA for approval before ship construction can begin.

Use of sophisticated models that can modify construction factors, including space size, construction materials, dimensions of materials used, etc., are recommended. This method allows multiple approaches to the design without actually building a physical ship, at which time it may be too late to fix the problem. It can also identify potential noise control issues that might not otherwise be evident in other review methods. The model should be exercised to perform trade-off studies with respect to acoustic performance and impact of the recommendations on weight, space, cost, and performance of the vessel. Treatments and materials shall meet shipboard and regulatory requirements for smoke, fire, and toxicity.

1.3.1.2 Compartment Treatment Plan. A plan shall be developed based on computer modeling listing various noise sources and use of treatments to comply with the compartment and noise exposure requirements. The plan shall be submitted to and approved by NAVSEA with the following information:

- a. Compartment list: a list of each compartment identifying all noise producing sources categorized by steady-state, intermittent, and impact noise; planned treatments; calculations used; and relevant supporting documentation. Expected crew exposure times by compartment shall also be provided.
- b. Report: a report shall be submitted listing the location of acoustic absorptive material and transmission loss treatments. The report may contain a table with the headings shown in Part I, [Table 1-1](#).

Table 1-1. Compartment Treatment Plan.

Compt name	Compt number	Noise source(s)	Treatment material, type, sound reduction level, & thickness/layers used (specify where used)						Total weight of treatment
			Overhead	Deck Under	FWD	AFT	Port	Stbd	

c. Hazardous noise list: a list of compartments with hazardous noise levels shall be submitted for NAVSEA review. This list shall include sufficient information on noise levels generated in compartments, such as machinery spaces, and the list shall include a mitigation plan to protect personnel hearing.

d. Resilient mountings list: a list of equipment with type and quantity of resilient mountings and the noise level to be achieved.

e. Treatment list: a list of acoustic absorptive treatments and materials, areas of application, salient material properties, expected replacement life, and potential vendors.

1.3.1.3 Noise Level Surveys. For newly designed ships, as well as ships based on earlier or repeat designs, noise level measurements shall be conducted for in-service vessels in accordance with ISO 2923. During the ship’s baseline industrial hygiene (IH) survey (one is required after the Navy accepts a ship), noise levels shall be measured throughout the ship’s spaces. These IH findings help identify noise-hazardous spaces by posting signage to warn users at noise-hazardous boundaries. These measurements should help designers understand where noise control issues have been encountered in the previous designs to incorporate fixes or controls in repeat or “based-on” designs.

1.3.1.4 Consultation with NAVSEA and Navy and Marine Corps Public Health Center (NMCPHC). NAVSEA and the NMCPHC retain a core of noise subject matter experts (SMEs) who can assist with engineering and other specialty issues (e.g., health-related concerns) involving noise. In addition to general technical expertise, these SMEs are familiar with historical noise control issues and can suggest approaches and techniques that can help designers avoid previously encountered pitfalls.

1.3.2 Whole-Body Vibration. For new ship designs, as well as ships based on earlier or repeat designs, evaluation of ship vibration within manned spaces and its possible effects on health, physical performance, mental work performance, and comfort shall be conducted in accordance with ISO 6954 or MIL-STD-1472, as modified to include a normal 16-hour day. Ships shall be designed to control the transmission of whole-body vibration to levels that will permit safe and effective operation and maintenance. Vibration mitigation plans shall be developed in accordance with MIL-STD-1472 and submitted to the Navy for approval.

1.4 LIGHTING.

Fluorescent lighting or Solid State Lighting (SSL) (see MIL-DTL-16377) shall be the primary source of general illumination in living and work spaces. SSL, such as Light Emitting Diodes (LEDs), Organic Light Emitting Diodes (OLEDs), or Polymer Light Emitting Diodes (PLEDs) should be considered, as much as practicable, to support reduced energy usage, reduced environmental impact, improved reliability and durability, longevity, recyclability, and reduced man-hours from fewer light replacements. Wherever general illumination is inadequate for efficient performance of specific tasks, detail illumination shall be provided for the specific functions. Lighting fixtures shall be arranged to provide uniform illumination so that the ratio of maximum footcandles under a lighting fixture to the minimum footcandles between it and the nearest adjacent fixture shall not be greater than two to one. Excessive brightness contrasts between “seeing task” and background immediately surrounding such task shall not exceed a ratio of ten to one. Arrangement of lighting fixtures shall be coordinated with ventilation terminals and other overhead interferences and integrated with equipment/furniture arrangement to achieve the best possible illumination within these requirements. Compartment illumination levels shall be as specified in Part I, [Table 1-2](#). Compartment illumination levels for those areas not specified in Part I, [Table 1-2](#) shall be in accordance with MIL-STD-1472 for the respective spaces specified.

Table 1-2. Compartment Illumination Levels.

Space	Average initial footcandles
General lighting (30 inches above deck)	
Passageways	7
Living spaces, except as follows:	14
Staterooms	7
Berthing areas	7
Sanitary spaces, except as follows:	14
Shower area	3
Food service and messing spaces	28
Refrigerated and dry provision storerooms	14
Lounge, recreation, and welfare spaces	14
Library multimedia resource center (LMRC)	28
Personal service spaces, except as follows:	14
Ship store	28
Post office	28
Vending machine area	7
Detail lighting	
Bulletin boards	14
Desk and writing tables	42
Food preparation counter, range tops, off-loading end of dishwashers, and food serving lines	42
Barber shop chair	42
Laundry press area	28

1.5 MATERIALS.

All interior finish materials and furnishings shall be in accordance with the fire performance requirements of MIL-STD-1623. Materials and applications which ease cleaning efforts and improve facilities maintenance shall be utilized throughout, with special emphasis in messing, food preparation, sanitary, and medical spaces. Additionally, the following requirements shall apply.

1.5.1 Carpeting. Shipboard carpeting shall be of approved material (Deck coverings shall be selected in accordance with NAVSEA Standard Item 009-26.) and installation shall be limited to Flag and Commanding Officer quarters, quarters of other officers of equivalent rank, Executive Officer quarters, wardrooms, Chief Petty Officer (CPO) lounges, library multimedia resource centers, and chapels. In areas of high traffic, such as wardrooms, CPO lounges, library multimedia resource centers, and chapels, deck tile may be substituted for carpet as a means to reduce maintenance and improve the longevity of the deck covering.

1.5.2 Bulkhead and Overhead Sheathing. Bulkhead and overhead sheathing is provided for health and sanitary purposes or for aesthetic purposes. Sheathing shall be in accordance with the fire performance requirements of MIL-STD-1623 as noted above.

1.5.2.1 Installation of Sheathing for Health and Sanitary Purposes.

a. Overhead and bulkhead sheathing shall be provided for health and sanitary purposes, in food preparation spaces, sculleries, garbage disposal rooms, medical and dental operating rooms, bacteriological laboratories, and dedicated battle dressing stations.

(1) Exception for sheathing may be made for reasons of maintenance and access, cost, and/or weight issues in the galley (except over cooking equipment, food serving equipment, and food preparation surfaces), sculleries, and garbage disposal rooms with NAVSEA approval. Where surfaces (e.g., cableways, lagged pipping) are not easily cleanable due to texture, accessibility, and durability (i.e., inability to withstand frequent cleaning and disinfection), they shall be sheathed.

(2) Every effort shall be made to ensure bulkhead and overhead surfaces are smooth and easily cleanable to prevent unnecessary contamination or illnesses. Pipes that carry contaminants, such as sewage or toxic liquids, shall not run directly over food preparation areas.

(3) Ensure, to the maximum extent possible, that pipes, ducts, wire ways, and other overhead fixtures or equipment are not installed above food preparation areas. Where pipes, ducts, wire ways, and other overhead fixtures or equipment must be installed above food preparation areas, ensure that the overhead installations are constructed to make them as easily cleanable as possible. Ensure that bulkhead construction provides the required ease of cleaning and where pipes, ducts, wire ways are at locations where they may expose food preparation areas to contamination, ensure that the bulkhead installations are sheathed or constructed to facilitate ease of cleaning. Any coatings applied in these unsheathed areas shall be smooth, easily cleanable, and in good repair.

b. Installation for humidity control and protection of insulation shall be provided in shower and shower drying areas.

c. Where thermal insulation is installed on structure behind fixtures, such as lavatories, service sinks, bucket fill stations, urinals, if provided, or WCs, it shall be covered with bulkhead sheathing.

1.5.2.2 Installation of Sheathing for Aesthetic Purposes. Sheathing installed for aesthetic purposes shall be limited to Flag and Commanding Officer quarters, quarters of other officers of equivalent rank, Executive Officer quarters, chapels, officer wardroom, messrooms, CPO messrooms, and CPO lounges. Sheathing for aesthetic purposes may be omitted for reasons of maintenance and access, cost, and/or weight issues.

1.5.2.3 Application of Sheathing. In all applications, sheathing shall be installed in a manner that will not impede damage control efforts. Full visibility and accessibility shall be provided for damage control fittings and other vital system components requiring access for inspection, maintenance, and operation. Sheathing in the way of valves, test fittings, electrical junction boxes, and other such system components requiring access, shall be provided with hinged access panels having quick-acting flush catches and having label plates which identify the enclosed component. To eliminate fire hazard accumulation behind and above sheathing, sheathing shall not be used to create a ventilation plenum. Sheathing installations shall have openings suitable to allow full access to enclosed ventilation systems for routine cleaning. Bulkhead sheathing shall not be applied along the shell of the ship in any space below the damage control deck.

1.6 SHIPBOARD HABITABILITY FURNITURE AND EQUIPMENT.

1.6.1 **Furniture and Equipment.** Shipboard habitability furniture and equipment shall conform to shipboard requirements for durability to withstand conditions at sea, hatchability, maintainability, reliability, as well as meeting requirements for fire and off-gas performance. All habitability furniture and equipment supplied by the contractor shall meet one or more of the following requirements:

a. The item is listed in the following U.S. Navy Shipboard Furniture and Equipment Catalogs (available at <http://usnhabeqptcatalog.gdit.com/>):

- (1) S9600-AD-GTP-010, U.S. Navy Shipboard Furniture Catalog
- (2) S6161-Q5-CAT-010, Naval Shipboard Food Service Equipment Catalog
- (3) S6152-B1-CAT-010, Shipboard Laundry Equipment Catalog

Note: The above Technical Manual Identification Numbers are cited throughout this document for convenience in referring to the type of equipment and for associating items in this document with the appropriate equipment catalogs at the above website. The website contains the most up-to-date listing of approved equipment and therefore supersedes the technical manuals.

b. The item is the subject of a NAVSEA hull type or standard drawing.

c. Furniture and equipment selected from other than the U.S. Navy Shipboard Furniture and Equipment Catalogs noted above shall be in accordance with MIL-PRF-32038 and shall be submitted to NAVSEA and the Habitability Life Cycle Manager (LCM) (Naval Surface Warfare Center, Philadelphia Naval Business Center, Habitability Section) for approval prior to procurement and installation.

1.6.2 Additional Requirements for Furniture.

1.6.2.1 **Styling.** Contemporary furniture styling is encouraged provided the furniture meets the salient requirements indicated in U. S. Navy furniture catalog S9600-AD-GTP-010 (see <http://usnhabeqptcatalog.gdit.com/>) and MIL-PRF-32038, and has been reviewed and approved by NAVSEA and the Habitability LCM (Naval Surface Warfare Center, Philadelphia Naval Business Center, Habitability Section) prior to procurement and installation.

1.6.2.2 **Size Constraints.** Furniture and equipment shall be designed to pass through a 26-inch by 66-inch access (with 8-inch radius corners). Items may be delivered in a knockdown condition and assembled within the space.

1.6.2.3 **Compatibility.** Furniture shall be compatible with the space and other furniture with which it is intended to be used. For example, chairs with arms that cannot be stowed within the table or desk knee-hole space shall not be selected.

1.6.2.4 **Attachment to Ship Structure.** All furniture and equipment, except for portable items such as chairs, shall be attached to the ship structure to prevent them from becoming "missile hazards" in a seaway. Attachments to structure usually consist of clips welded to the deck, overhead or bulkheads, or of sub-bases welded to the deck. Areas subject to highly varying deck loads, such as from gun blast, guided missiles, aircraft landings, or vehicular traffic, shall be provided with deflection fittings to allow the structure to flex without crushing or deforming attached furniture (Connections with sliding fit shall be tight enough to prevent rattle.). Large furniture items shall be supported on the bottom by sub-bases (or other approved applications) and secured at the top and/or sides by hasps, sway braces, or similar means of attachment.

1.6.2.5 **Built-in Furniture.** Built-in furniture may be installed where a more satisfactory arrangement can be obtained. Where practicable, built-in furniture shall be fitted into corners, around stanchions, and structural members where compartment volume can be optimized. When built-in furniture is used, it shall be in general accordance with MIL-PRF-32038. Built-in furniture finish shall be air-dry enamel paint in accordance with MIL-DTL-24607 or powder epoxy coating in accordance with MIL-PRF-24712, or a commercial equivalent.

1.6.2.6 **Construction.** Unless otherwise specified herein or by NAVSEA-approved specifications or drawings, furniture shall be of aluminum construction.

1.6.2.7 **Furniture with Horizontal Surfaces.** Horizontal surfaces, which are covered with a high-pressure plastic laminate in accordance with MIL-P-17171, shall be protected against delamination, such as a flush corrosion-resistant steel (CRES) or extruded aluminum metal edge binder.

1.6.2.8 Interchangeability. Furniture designed for easy interchangeability to meet mission needs shall be installed without welding. This type of furniture shall use standardized mounting to allow interchangeability with any type of furniture. If furniture is bulkhead-mounted, bulkheads shall be designed to support the furniture, including the effect of ship motions, and shall meet shock grade when required. Adequate space shall be provided between bulkhead-mounted furniture and the deck to allow for cleaning.

1.6.3 Portable Furniture and Equipment. Portable furniture and equipment shall be equipped with tie-downs at stowage locations. Furniture and accessories that are provided for intermittent use, such as folding chairs, shall be provided with stowage locations with tie-downs.

1.6.4 Installed Furniture and Equipment. Installed furniture and equipment shall not block access to damage control fittings or to the hull, mechanical, or electrical distributive systems that require periodic inspection and maintenance. Berth partitions or other furniture partitions installed in the way of valves, operating gear, or test fittings shall be provided with quick-acting access panels. Label plates shall be mounted where readily visible to indicate hidden fittings.

1.6.5 Hooks and Racks. Coat and hat hooks shall be mounted 77 inches above the deck or as high as structurally feasible to preclude personnel hazard, shall be of commercial non-corroding metal, and shall be provided in sufficient quantities to accommodate normal occupancy in working spaces, wardroom, messrooms, lounges, LMRC, physical fitness spaces, and training spaces. In officer and CPO berthing spaces, one hook per accommodation shall be provided, and in each crew living (berthing) space, one hook per ten accommodations shall be provided. Each hook shall support 65 pounds and shall be located to preclude personnel hazard. Hooks, racks, and similar articles shall not be attached to the panels of furniture if other locations are practicable. Where these articles must be attached to furniture, adequate reinforcement shall be fitted to provide rigidity and to prevent distortion of furniture.

1.6.6 Fastenings. Fastenings shall not present any sharp edges or irregularities that could injure personnel or damage clothing.

1.6.7 Bulletin Boards. Bulletin boards or electronic boards shall be provided in the vicinity of manned spaces. A table of bulletin board locations shall be submitted to NAVSEA for review and approval.

1.6.8 Chairs. Chairs, other than stacking chairs, shall be provided with glides of the non-slip, swivel type. Casters shall not be provided on chairs. Foam rubber padding for chairs, transoms, and benches shall be in accordance with MIL-STD-1623, with the additional requirement that the foam rubber padding shall be in accordance with MIL-PRF-20092, Type II, Class 5, Condition C.

1.6.9 Arrangement and Location. Furniture and equipment arrangements shall be coordinated with the ventilation, piping, and wiring installation to create an orderly appearance in the compartment without compromising functional efficiency. Clothes lockers shall not be located in sanitary or food service spaces.

1.7 COLOR.

Officer, CPO, and crew living and work spaces shall have an adequate number of different color schemes to provide personnel with a visual change in environment in their daily routines. The total number of different colors of paint and deck coverings used, however, should be kept small to minimize logistics support. When practicable, selection of color schemes for senior officers' quarters, messrooms, and lounges may be made by the prospective Commanding Officers. Paints and other materials used on large surface areas shall be of appropriate color and reflectance to ensure proper lighting. Curtains, draperies, and other accent materials need not be standard in color or pattern. See Part II, 1.7 for further guidance on color schemes.

1.8 PERSONNEL ACCESS CLEARANCES AND ACCESS SAFETY.

1.8.1 Overhead Clearance. Unobstructed headroom in habitability associated walking areas and passageways shall be not less than 6 feet 5 inches.

1.8.2 Walking Area Clearances.

a. Minimum unobstructed widths in habitability associated areas shall be 36 inches for main walkways and 30 inches for secondary walkways, unless otherwise specified herein.

b. For minimum unobstructed widths of primary and secondary passageways, see T9070-AB-PRO-010.

1.8.3 Access Safety. Outside corners of bulkheads in all manned spaces and passageways shall be rounded to have a radius of at least 0.5 inch.

1.9 FRESH WATER.

1.9.1 Fresh Water Production and Stowage Capacity.

1.9.1.1 Fresh Water Production for Habitability. All ships shall have a desalination production capacity adequate to provide, in addition to other non-habitability requirements, 40 gallons per accommodation (including ship's company and any embarked personnel [troops, air wings, staffs, detachments, regular short-term assignments, indoctrination personnel, civilian technical representatives, and official visitors or guests]), per day, of fresh water of acceptable quality to support habitability (drinking, galley, scullery, personnel hygiene, and laundry).

Two distilling or reverse osmosis plants shall be provided; one shall be equal to required design capacity and the second shall be a full redundant plant. As an alternative, three or four plants of equal capacity each may be provided, such that with one plant secured, the remaining plants have a combined capacity equal to or greater than the required design capacity.

1.9.1.2 Fresh Water Stowage for Habitability. All ships shall maintain a stowage capacity for a minimum of 40 gallons per accommodation for habitability purposes.

1.9.2 Water Coolers. Water coolers shall be provided for living and work spaces. Where several small spaces are closely grouped and share a common passage, one cooler may service the group. Water coolers for living and messing spaces shall be in accordance with Part I, [Table 1-3](#) and Part I, [Table 1-4](#).

Table 1-3. Water Cooler Requirements for Living and Messing Spaces on Surface Ships.

Occupants	Max # accommodations per water cooler in passage serving living area	Max # mess seats per water cooler per messing space
Officers	40	75
CPO/SNCO	40	75
Crew/Troop	100	50

Table 1-4. Water Cooler Requirements for Spaces Other Than Living and Messing Spaces.

Space	Minimum quantity
Main machinery space	1 each level
Auxiliary machinery space	1 each level
Shop (in passage)	1 per group
Control station	1 each
Ready room	1 each
Medical treatment (in passage)	1 each
Hospital area (outside ward)	1 each
Office area (in passage)	1 per group
Hangar	2 per bay
Dental area (in passage)	1 each
Combat Information Center (CIC)/C4I, Ship Mission Center	1 each
Bridge	1 each
LMRC (in passage)	1 each
Brig facility	1 each
Laundry room	1 each
Physical fitness room	1 each
Damage Control Repair Stations (in passage)	1 each
Unit Patrol Lockers/Stations (in passage)	1 each
Self Service Laundry	1 each

1.9.3 **Ice Making.** See Part I, 2.5.9.4 for ice making requirements.

1.9.4 **Water Heaters.** Water heaters shall be provided in numbers sufficient to ensure an adequate supply of hot water at all washbasins and showers and shall include a system which ensures a hot water supply to showers and washbasins within 10 seconds. Water heaters shall be provided for galley, pantry, scullery, laundry, and medical and dental spaces. Water heaters supplying washbasins and showers shall not support work spaces that have higher water temperature requirements. To avoid scald injuries, the temperature setting for the water heaters serving habitability space showers and lavatories shall be in accordance with NAVMED P-5010-6. Water heaters and water heating systems provided for ship's laundry shall provide a minimum 120 °F hot water supply to laundry equipment at a flowrate sufficient to allow for efficient operation of all laundry equipment and not inhibit design operational characteristics.

1.9.5 **Water Disinfection.** Shipboard potable water disinfection requirements shall be in accordance with NAVMED P-5010-6.

1.9.6 **Emergency Wash Facilities (EWF).** Emergency wash facilities requirements shall be in accordance with OPNAVINST 5100.19.

CHAPTER 2 HABITABILITY FACILITIES (ACCOMMODATIONS AND PERSONAL SERVICES)

2.1 GENERAL.

The number of accommodations referred to herein shall be that number stated in the CDD or individual ship specification. Habitability support facilities shall be provided and sized based on the determined number of personnel assigned to the ship, including the ship's company plus any of the following embarked personnel: troops, air wings, staffs, detachments, regular short-term assignments, indoctrination personnel, civilian technical representatives, and expected official visitors or guests. Habitability support is generally not provided for surge personnel embarked for short durations for special operations, exercises, or mobilizations, under which extraordinary circumstances are accommodated with a berth only. The number of surge personnel shall not overwhelm habitability services which are limited to supporting permanently assigned and embarked personnel assigned to the ship. Otherwise, increase in specific habitability support shall be considered to accommodate surge personnel such as Marine Sanitation Device (MSD) capacity, fresh water production and stowage capacity, and provisioning. Ships that receive a steady influx of transients shall also require support for them so that habitability for permanently assigned personnel is not degraded. Requirements of NAVMED P-5010, Chapters 1, 2, and 6 shall apply to habitability facilities.

2.1.1 Accommodation Design Margin and Service Life Allowances. The accommodation design margin and service life allowances (SLA) shall form the basis in the development of habitability facilities. An accommodation design margin of between 5 to 10 percent is an acceptable range for use in early stage ship design, apart from SLA, to account for expected growth in manning requirements, as they are better defined and mature from early stages of design stage to detail design. The design margin is necessary to accommodate risk, variability, and unknowns. SLA shall be provided to accommodate normal growth necessary for mission upgrades over the ship's service life. A 10 percent SLA shall be provided at ship delivery for officer and enlisted personnel to permit anticipated growth in accommodations during its service life. The 10 percent SLA applies only to ships' force and not to embarked personnel.

2.2 BERTHING SPACES.

2.2.1 Berthing Requirements. There shall be at least one berth per accommodation. Berthing spaces shall be physically separate from passages and other spaces by a minimum of a light-tight bulkhead or better. Berthing facilities shall not be used as a pass-through for access to other normally manned spaces or unmanned spaces that require routine access such as storerooms. Berthing spaces shall be arranged in groupings of living quarters. Berthing spaces shall not be located forward of the collision bulkhead or immediately beneath machinery spaces or working spaces with considerable noise and vibration. Main steam pipes or engine uptakes shall not pass through berthing spaces. Berthing spaces shall not be located in areas that put the health, safety, and survivability of personnel at risk (such as above the main deck fantail on aircraft carriers).

2.2.2 Personnel Groupings. Separate berthing compartments shall be provided for Officers, CPOs, and enlisted crew. Separate accommodations shall also be provided for embarked personnel, detachments, air wing, staff, and short-term assignments, including transients, indoctrination personnel, civilian technical representatives, and official visitors. On amphibious ships, embarked personnel also include troop officers, SNCOs, and enlisted troops. Separation of officer berthing compartments shall be defined according to rank with longitudinal dispersal as appropriate in order to enhance senior staff survivability. Separate berthing facilities shall be provided for male and female personnel. Berthing facilities shall be gender neutral and shall be designed to accommodate any ratio of male and female population.

2.2.3 Sea Cabins. On all surface ships, destroyer/frigate size or larger, a sea cabin shall be provided for the Commanding Officer in the immediate vicinity of the bridge/control station if the Commanding Officer stateroom is not in the immediate vicinity of the bridge/control station. On all surface ships specifically configured to carry embarked Flag Officers and/or Unit Commanders requiring immediate access to the bridge/control stations, such cabins shall be provided if staterooms are not in the immediate vicinity of the respective control station.

2.2.4 Berths.

2.2.4.1 Type. Berths shall be of the pan-bottom or locker-bottom type, and shall be permanently installed, except where designated as surge berthing or in the case where the berths are covering a manhole cover or tank lid, the bottom berth shall be of the removable type. Surge berths shall either be permanently installed as fold-away in berthing spaces or be of a removable type to allow for expansion in lounge spaces during periods when not occupied.

2.2.4.2 Berth Tier. The term “tier” as used herein denotes the berth structure of two- or three-high berths.

2.2.4.3 Berth Cubicle. A berth cubicle shall consist of up to two berth tiers of no more than six accommodations per cubicle with a single entryway. The number of accommodations per berth cubicle may increase up to 4 berth tiers of no more than 12 accommodations on a case basis for large deck ships (carriers, amphibious assault ships, and large auxiliaries). The head of the berth shall be located away from the entry, where practical. Each berth cubicle shall have an overhead HVAC terminal.

2.2.5 Berthing Clearances. Minimum clearance requirements to ensure freedom of rotation of individuals in their berths, access to berths, and traffic flow in berthing compartment/between berths, shall be in accordance with the following criteria:

- a. Vertical unobstructed clearance above mattress top:
 - (1) Enlisted crew/troop: 20 inches for three-high berths and 36 inches for two-high berths.
 - (2) CPO/SNCO: 23 inches for three-high berths and 36 inches for two-high berths.
 - (3) Officers: 23 inches for three-high berths and 36 inches for two-high berths.

Note: Where 36 inches unobstructed vertical clearance is unattainable for two-high berths due to overhead obstructions and there is no alternative location, reducing height is permitted on an as needed basis to a clearance of not less than 23 inches for enlisted crew/troops and CPO/SNCO and 25 inches for officers.

- b. Unobstructed main walkway width within berthing areas: 36 inches.
- c. Unobstructed secondary walkway width at berth tier ends: 30 inches.
- d. The unobstructed walkway width along accessible side of berth shall be (excluding protrusions for steps, lift or pull handles, lock hasps and staples, and combination locks) 27 inches. On a case basis, the full accessible length may be reduced to not less than 57 inches for lockers installed against the bulkhead at the end of the cubicle. Where feasible, when cubicles contain four berth tiers on large deck ships, the minimum walkway clearance shall be increased from 27 inches to 30 inches.
- e. Where feasible, the unobstructed walkway clearance height along accessible side of berth tiers shall be equal to the height of the berth but not less than 6 feet 5 inches.
- f. The minimum distance from the underside of the bottom berth mattress to the deck shall be not less than 6 inches. In cases where the overhead structure or other interferences prevent obtaining the minimum vertical headroom clearance above the mattress top, the minimum distance from the underside of the bottom berth mattress to the deck shall be not less than 2 inches. However, only those berths that cannot maintain the minimum headroom clearance above the mattress due to overhead interferences shall be permitted to utilize a 2-inch minimum distance from the underside of the bottom berth mattress to the deck. All other berths within the same living space shall maintain the minimum 6-inch distance from the underside of the bottom berth mattress to the deck.

2.2.6 Berth Features. The following features shall be included for each berth except surge berths, as noted:

- a. One light per berth. Provide berth light with electric receptacle on new construction ships and on existing ships that have the electric generating capacity to support the additional load.
- b. Full privacy partitions between berths and at ends of berth tiers where opening onto passageways unless otherwise provided by the berth design.
- c. Privacy curtains for each berth, except officer single berths.

d. Officer berths shall be provided with lee rails. Clips for stowage of berth lee rails shall be installed in an inconspicuous location within the berthing space. Enlisted berths shall be provided with lee straps. Lee straps shall be permanently attached to the berth. However, lee rails may be used for enlisted berths in lieu of lee straps if a common design feature is desired for all berths.

e. Access in locker-bottom type berth. Means for easy reach to all portions of the locker space shall be ensured when a locker bottom is provided for the top and middle of a three-high berth or the top of a two-high berth.

f. In enlisted berthing spaces with multiple berth cubicles, lower berth tiers shall be provided with kick-out panels for all berth tiers not located against bulkheads or other obstacles to allow for secondary means of escape in the event the primary access to the berth cubicle is obstructed.

g. All enlisted berths shall be sized to fit an 80-inch mattress where practicable. Otherwise, a minimum of 10 percent of all berths shall be sized to fit an 80-inch mattress and the remaining berths shall accommodate at least a 76-inch mattress.

2.2.7 Space Considerations. The following shall be taken into consideration for berthing spaces:

a. Berths shall be oriented primarily fore and aft; however, athwartship berthing may be used where the compartment arrangement is improved. Where the athwartship orientation is used, it shall be limited to not greater than 30 percent of the berths.

b. Additional means of egress shall be provided in living spaces containing 21 or more accommodations. Consideration shall be made when a passage shared by a group of living spaces, staterooms, and/or bunkrooms offers only a single means of escape. Alternative means of escape shall be considered to other passages or access routes via scuttles, doors, and kick-out panels.

c. A stateroom shall accommodate one to three occupants and a bunkroom shall accommodate four to six occupants.

d. Where feasible, berths in living spaces shall be arranged so as to be screened by partitions or furniture from the portion of the space used for other purposes. Where berths are located near an entry door or sanitary space door, privacy for such berths shall be provided by furniture or a partition.

e. Furnishings (lockers, drawers, etc.) in berthing spaces with more than one occupant shall be labeled to associate them to a berth.

f. A full-length mirror made of laminated glass shall be provided in berthing spaces, 1 in each stateroom and bunkroom, and in each berthing space based on 1 per 24 accommodations or fraction thereof. The top of the mirror shall be 74 inches above the finished deck.

g. Unless otherwise specified herein or by NAVSEA-approved specifications or drawings, outside corners of bulkheads, doors, bulkhead sheathing, and partitions in berthing spaces that crew members may strike shall be rounded to have a radius of at least 0.5 inch.

h. A trash receptacle shall be provided in each living space.

2.2.8 Enlisted Personnel. Compartment requirements for enlisted personnel shall be as follows:

a. Berthing spaces shall be provided with berth tiers arranged in cubicles.

b. Berthing spaces shall be as noted below.

2.2.8.1 Enlisted Crew and Troops.

a. Where feasible, the preferred range of berthing space configurations is a mix of 4- to 12-person berthing spaces. The threshold shall be to provide a mix of berthing space configurations ranging in size from 6-person bunkrooms to 48-person berthing spaces. Consideration shall be made to ensure the mix of compartment sizes provided will accommodate any ratio of male and female population. Berthing spaces in excess of 48 persons shall be formally requested and approved by NAVSEA.

b. Berths may be selected from one of the following types: two-high berths with adequate headroom to allow for a sit-up position or three-high berths. Transient enlisted crew or troops may be provided with three-high berth tiers.

c. A minimum of 1 fold-down writing surface and chair shall be provided within each bunkroom, and 1 for every 10 enlisted accommodations within each living space. Fixed writing surfaces, such as a desk or table, may be provided in lieu of fold-down writing surfaces where feasible.

2.2.8.2 CPOs and SNCOs.

a. Where feasible, the preferred berthing spaces are four-person bunkrooms. The threshold shall be to provide a mix of four- to six-person bunkrooms. On large deck ships, to optimize savings in cost and area/volume, the threshold may be increased to provide a mix of 4- to 6-person bunkrooms to 12-person berthing spaces on a case basis. Consideration shall be made to ensure the mix of compartment sizes provided will accommodate any ratio of male and female population. Berthing spaces in excess of six persons shall be formally requested and approved by NAVSEA.

b. Berths shall be provided with two-high berths with adequate headroom to allow for a sit-up position. On large deck ships, consideration may be made when space availability is an issue, that berths for CPO or SNCO personnel may be provided with three-high berth tiers. Transient CPOs or SNCOs may also be provided with three-high berth tiers.

c. One fold-down writing surface (or where practicable, a secretary bureau with drop-leaf) and chair shall be provided per three CPO/SNCO accommodations per bunkroom. When berthing spaces for up to 12 occupants are included on a case basis for large deck ships, 2 fold-down writing surfaces and 4 seats shall be provided.

d. One bulkhead-mounted, fold-down chair should be provided (when practicable) in each berthing cubicle located in berthing spaces.

2.2.8.3 Command Master Chief and Command Sergeant Major. The Air Wing and Ships Company Command Master Chief of the ship and Command Sergeant Major shall be provided with a stateroom and it shall be adjacent to their respective CPO or SNCO living areas.

2.2.9 Officers. Compartment requirements for officers shall be as follows:

a. Officers shall be accommodated in one- or two-person staterooms. On large deck ships, consideration may be made, when space availability is an issue, no more than six berths per officer bunkroom (eight berths per transient officer bunkroom) may be provided on a case basis. Consideration shall be made to ensure the mix of compartment sizes provided will accommodate any ratio of male and female population.

b. Unobstructed walking and working areas in officer berthing spaces shall conform, as a minimum, to Part I, [Table 2-1](#). Columns in Part I, [Table 2-1](#) specifying ship length refer to length overall. The net walking and working areas include the deck area that is clear of fixed furniture such as berths, lockers, and wardrobes. The area under chairs, retractable sections of folding lavatories, and the drop-leaf of secretary bureaus is included in net walking area. Areas that are too small or too obstructed to serve as normal foot traffic areas, such as those between bulkheads and adjacent furniture, are excluded from net walking area.

c. Staterooms assigned for Commanding Officer, Commanding Officer of Troops, Landing Force Commander, Air Wing Commanders, and other senior operational commanders shall be commensurate with and appropriate to the rank of the individuals concerned. Adjoining cabins shall be provided for all such staterooms. The cabin shall be provided with means for use as an office and as a conference/lounge area.

d. Writing spaces (desk or secretary bureau with drop-leaf) and chairs shall be provided in officer, troop officer, and transient officer quarters on a basis of one per one, one per two, and one per three accommodations, respectively.

e. For officer staterooms having more than one occupant and for officer bunkrooms, berth ends not screened by furniture or partitions from the rest of the space shall be provided with curtains. Curtains for transom berths shall not interfere with their use as a seat.

Table 2-1. Unobstructed Area in Square Feet per Officer Accommodation.^{1/}

Officers' accommodations	Ship length 150 – 300 feet	Ship length 301 – 600 feet	Ship length over 600 feet	Troop officers
CO single stateroom	45 – 50 ^{2/}	55 – 70 ^{2/}	65 – 90 ^{2/}	55 – 70
XO single stateroom	35 – 40 ^{3/}	40 – 55	45 – 70	55 ^{3/}
Dept. head single stateroom	30 ^{3/}	30 – 45	45 – 60	45 ^{3/}
Single stateroom	N/A ^{4/}	35 ^{3/}	35 – 50	30 ^{3/}
Double stateroom	20	22	35	18
Officers' bunkroom	20 ^{5/}	20 ^{5/}	20 ^{5/}	12
NOTES: ^{1/} The lower figure is the minimum limit. The higher figure is the design goal. ^{2/} Does not include sea cabin space, when provided. ^{3/} When such spaces are provided. Optimum ship construction considerations may preclude provision in every case. ^{4/} N/A = Not Applicable. ^{5/} Transient officer bunkroom: 12 square feet.				

2.3 STOWAGE FOR PERSONAL GEAR AND EFFECTS.

2.3.1 Stowage for Personal Effects. The standards for personal stowage space displayed in Part I, [Table 2-2](#) shall be provided for officers, enlisted personnel, and short-term assignments.

Table 2-2. Stowage per Accommodation.

Stowage type	Officers			Enlisted	
	Single stateroom	Double stateroom	Bunkroom	CPO/SNCO (E-7 to E-9)	Crew/Troop (E-1 to E-6)
Drawer volume (cu ft)					
Ship's company	20	15	15	1 ^{1/}	1 ^{1/}
Troops	18	10	10	2.9	1 ^{1/}
Short term ^{2/}	1 ^{1/}	1 ^{1/}	1 ^{1/}	1 ^{1/}	1 ^{1/}
Locker volume (cu ft)					
Ship's company	5.5	4.8	4.5	14 ^{3/}	13 ^{4/}
Troops	3.5	3.5	2.9	10	7.5
Short term ^{2/}	1 ^{1/}	1 ^{1/}	7.5	1 ^{1/}	1 ^{1/}
Hanging space (in.) ^{5/}					
Ship's company	24/24	24/12	24/12	12/6	10/0
Troops	12/12	12/6	12/6	12/6	10/0
Short term ^{2/}	1 ^{1/}	1 ^{1/}	10/0	1 ^{1/}	1 ^{1/}
Seabag stowage ^{6/} (cu ft)					
Ship's company	3	3	3	2	1
Troops	1 ^{1/}	1 ^{1/}	1 ^{1/}	1 ^{1/}	1 ^{1/}
Short term ^{2/}	1 ^{1/}	1 ^{1/}	2	1 ^{1/}	1 ^{1/}
Soiled laundry stowage (cu ft) for ships over 500 accommodations					
Ship's company	1 ^{1/}	1 ^{1/}	1 ^{1/}	1 ^{1/}	0.5
Troops	1 ^{1/}	1 ^{1/}	1 ^{1/}	1 ^{1/}	0.5 ^{7/}
Short term ^{2/}	1 ^{1/}	1 ^{1/}	1 ^{1/}	1 ^{1/}	1 ^{1/}
NOTES:					
^{1/} Not required.					
^{2/} Short Term includes transient personnel.					
^{3/} 10 cu ft of locker volume may be provided in a locker bottom berth and the remainder of 4 cu ft of locker volume shall be provided in a separate deck mounted locker. For pan only type berth without a locker under, 14 cu ft of locker volume may be provided in a deck mounted locker(s).					
^{4/} 7.5 cu ft of locker volume may be provided in a locker bottom berth and the remainder 5.5 cu ft of locker volume shall be provided in a separate deck mounted locker. For pan only type berths without a locker under, 13 cu ft of locker volume may be provided in a deck mounted locker(s).					
^{5/} The first number represents short hanging space (minimum 37 inches high), and the second number represents long hanging space (minimum 65 inches high).					
^{6/} Seabag stowage need not be in or adjacent to berthing spaces.					
^{7/} Lockers for soiled laundry stowage are optional for troop living spaces. These may be considered on a case basis.					

2.3.2 Troop Field Pack and Arms Stowage. In addition to the foregoing requirements, secure stowage for troop hand-carried weapons, helmets, field packs, and flak jackets shall be provided on all applicable ships (adjacency to berthing spaces is preferred but not required). Embarked troop rifle stowage shall be provided in racks in the troop berthing area. Stowage of one rifle per accommodation shall be provided. Stowage for other troop weapons shall be provided in the troop armory.

2.3.3 Work Clothing Lockers. Clothing lockers capable of containing one change of working uniform/one set of coveralls and shoes shall be provided in each main engineering/machinery space, sufficient to accommodate each watchstander in a watch section.

2.3.4 Aviation Personnel Flight Gear Clothing Lockers. On aircraft carriers and other ships designed to accommodate aviation personnel, stowage space in addition to that in Part I, [Table 2-2](#) shall be provided for officer and enlisted air crew, capable of accommodating individual flight equipment (helmet, flight suit, harness, survival equipment, and boots). This shall take the form of hanging space or lockers within berthing spaces or briefing/ready rooms and/or additional locker rooms convenient to briefing/ready rooms.

2.4 SANITARY SPACES.

2.4.1 General. Sanitary spaces shall meet the following general criteria:

- a. Sanitary compartments shall be well lit, heated, and ventilated and have non-slip type deck covering.
- b. Sanitary spaces are considered wet spaces and bulkheads surrounding these spaces shall have a minimum of a 6-inch watertight CRES coaming at the deck.
- c. Deck coverings in sanitary spaces shall be durable, easily cleaned and maintained, have good slip resistance, and be aesthetically pleasing. For both new construction and existing ships, deck coverings shall be selected in accordance with NAVSEA Standard Item 009-26.
- d. Deck covering within sanitary spaces shall be sloped toward the drains.
- e. All fixtures, fittings, and accessories shall be of high grade commercial marine quality and utilize non-pilferable fasteners where practicable.
- f. Piping shall be installed high enough above the deck to provide adequate space for preservation and cleaning.
- g. Attachment of plumbing fixtures to watertight and oiltight structure shall be avoided.
- h. Plumbing fixtures shall not be mounted directly on plating which is subject to deflection from gun blast or missile blast. In such locations, fixtures shall be secured to framing which shall be supported on flanges of stiffeners or to stanchions secured at the deck, and arranged for a sliding fit at top, tight enough to prevent rattle. Piping connections to these fixtures shall be flexible enough to prevent localized stresses being induced in fixtures by deflection of structure to which the piping and hose connections are secured. Fixtures in such locations shall be mounted with concussion washers or shock mounts. Braided, CRES jacketed, flexible piping may be used between the cut-off valve and each lavatory. The flexible piping shall be National Sanitation Foundation (NSF) approved for drinking water and have an automatic shutoff device installed before water enters the flexible piping. The flexible piping shall not exceed 24 inches in length or a maximum of ½-inch Nominal Pipe Size (NPS), nor penetrate any boundary which is fumetight or better.
- i. Where plumbing is concealed by sheathing or panels and access is required for inspection, repair, and maintenance, a removable panel or a hinged panel with quick-acting flush catch shall be provided.
- j. Where access is required to damage control fittings, valves, electrical junction boxes, and other such system components concealed by sheathing or panels, a hinged access panel with quick-acting flush catch and a label plate which identifies the enclosed component shall be provided.
- k. Water heaters shall be located outside of sanitary and berthing spaces and shall be provided with adequate insulation and exhaust ventilation to prevent high space temperature in their location.

2.4.2 Cleaning and Maintenance. The following criteria shall be taken into consideration for the cleaning and maintenance of sanitary spaces:

a. Adequate clearance shall be provided around and behind sanitary fixtures to easily adjust, service, or repair them, to reach plumbing connections and pipes, and to facilitate cleaning. Decks and bulkhead surfaces shall be easily cleanable and be impervious to moisture absorption. All areas shall be accessible for cleaning. The interior corners of sanitary spaces shall have a radius for ease of cleaning.

b. All components shall be designed to have a long service life in a wet environment, be easily cleanable, without cracks, crevices, or pockets that will harbor water, dirt, bacteria, or vermin. Service sinks and washbasins in lavatory units shall be sloped towards the drain in order to provide complete drainage and prevent standing water.

2.4.3 Heating and Ventilation. Mechanical exhaust ventilation shall be installed over WC areas and over shower areas. Grilles shall be located in bulkheads separating sanitary spaces from berthing spaces or passages for natural supply ventilation. Grilles shall be located to suit HVAC system design. Bulkhead-mounted convection heaters shall be provided within sanitary spaces to supplement heating of natural ventilation when compartment heat loss calculations determine supplemental heating is required. Heaters and other heating apparatus shall be placed, and, where necessary, shielded to avoid risk of fire or danger or discomfort to the occupants.

2.4.4 Sanitary Facilities for Personal Hygiene, Grooming, and Elimination of Bodily Fluids. Sanitary facilities shall be in accordance with the following:

- a. All sanitary facilities shall be designed to accommodate either male or female personnel.
- b. The following are types of sanitary facilities provided on Navy ships:
 - (1) Community sanitary space
 - (2) Bath
 - (3) Private toilet/shower (Private T/S)
 - (4) Semi-private toilet/shower (Semi-private T/S)
 - (5) Deck washroom/water closet (Deck WR/WC)

2.4.4.1 Sanitary Facilities Serving Berthing Areas.

- a. Personnel shall not have to cross primary passages or transit decks to reach their assigned sanitary space.
- b. Community sanitary spaces shall be located in the vicinity of and on the same deck level as the living space served.
- c. Community sanitary spaces shall typically be contiguous with and accessible from within the berthing spaces served. Private or semi-private T/S space or bath shall also be directly accessed from within the stateroom or bunkroom served.
- d. On large deck ships, to optimize savings in material, weight, volume, and cost, several staterooms or bunkrooms may be served by a community sanitary space instead of private or semi-private T/S spaces. The community sanitary space shall only be accessible from a secondary passage (preferably a dead-end passage) in order to provide a measure of privacy.
- e. Consideration shall be made to ensure the number and size of community sanitary spaces provided will accommodate any mix of male and female population assigned to the ship.
- f. On amphibious ships, separate sanitary facilities shall be provided for troops (officer, SNCO, and other enlisted).
- g. The quantity for each type of major fixture in community sanitary spaces serving an adjacent living space or a group of staterooms and/or bunkrooms shall be determined by the accommodations per fixture in Part I, 2.4.10. In community sanitary spaces, access to washroom facilities shall be designed to eliminate the need for passing through a WC area en route to or from the washroom facility. Showers and toilets shall be located as far from access doors into the sanitary compartment as practicable. Minimum walkway clearances for sanitary fixtures shall be in accordance with Part I, [Figure 2-1](#).

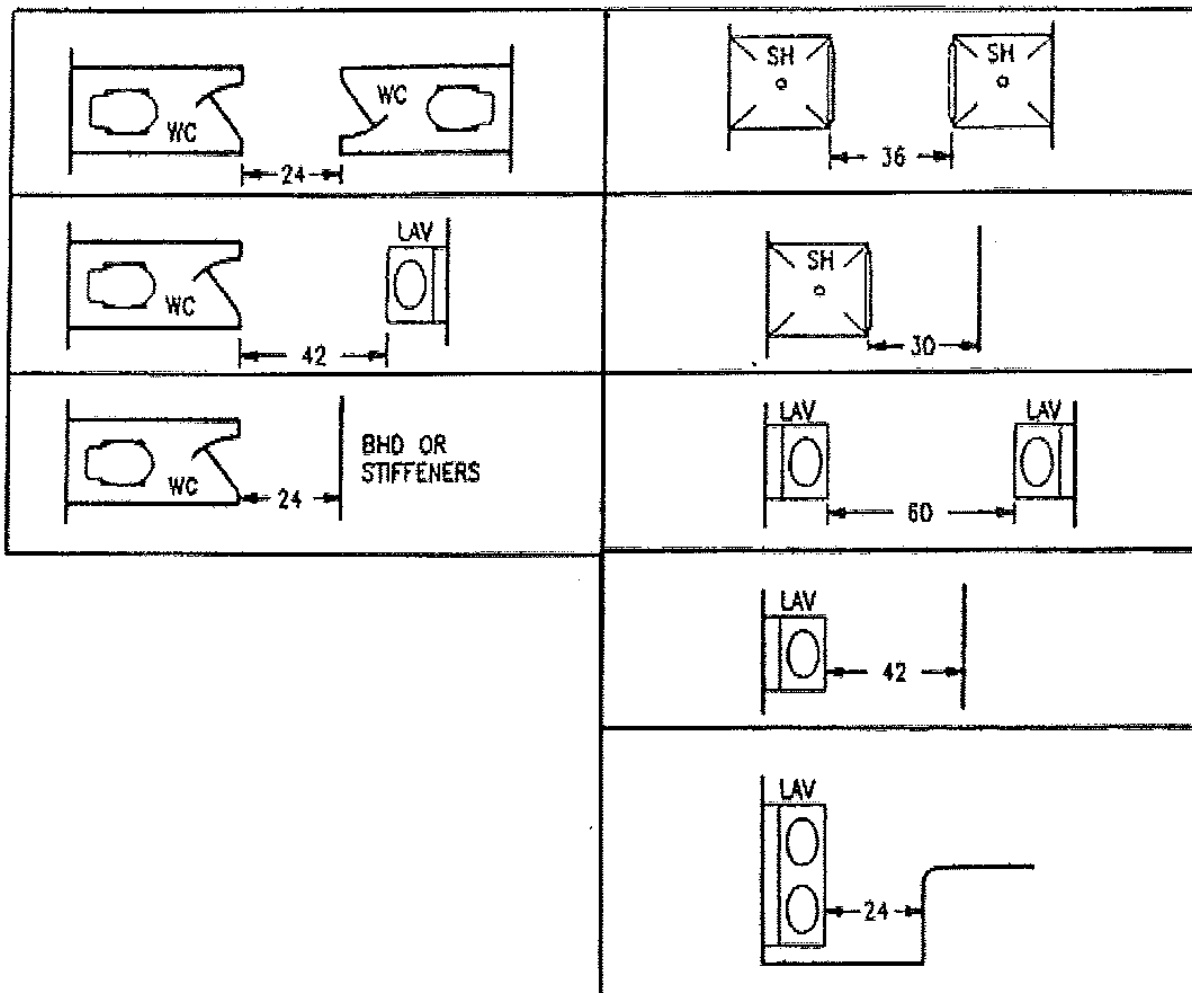

Figure 2-1. Community Sanitary Space Minimum Clearance Requirements.

h. Private and semi-private T/S spaces shall be in accordance with the following:

(1) Private T/S shall be provided adjacent to a stateroom serving one or two accommodations where a bath is not required. A private T/S shall contain a WC and curtained shower. A private T/S permits only one person to use this space at a time.

(2) Semi-private T/S shall be provided adjacent to a bunkroom, or between two adjacent staterooms serving a total of no more than six accommodations. A semi-private T/S space shall contain a WC enclosure with privacy door and a vestibule area between it and the curtained shower. A semi-private T/S permits two people to use this space at the same time.

(3) Private and semi-private T/S spaces require a lavatory unit in each stateroom or bunkroom.

i. A bath is a sanitary space containing a WC, a shower, and a lavatory. Private baths shall be provided for senior officers whose staterooms have adjoining cabins; bath access shall be from the stateroom. In cases where there is no adjoining cabin, a private bath shall be provided for the CO in all ships, and for the XO in destroyer size and larger ships. Privacy partitions are not required for the WC in the bath.

2.4.4.2 Deck WR/WCs Serving General Areas of the Ship.

a. Deck WR/WC spaces shall be provided where needed to serve personnel near watchstanding areas, work areas, and in areas where large numbers of personnel are situated.

b. Deck WR/WCs shall be provided in the immediate proximity to the bridge/pilot house, combat information center, and communication spaces used by watchstanders and shall also be provided to serve nearby messdeck areas. Deck WR/WCs shall also be provided in, or adjacent to, the accesses to firerooms, enginerooms, and other normally manned main machinery spaces.

c. Deck WR/WC shall be accessed from a passage and shall be considered for serving such areas as the office complexes, squadron ready rooms, workshops, and near stateroom/bunkroom complexes.

d. In areas where usage volume demands are high (i.e., messdeck), additional deck WR/WC spaces shall be provided on the basis of 1 toilet per 75 accommodations.

e. A deck WR/WC shall include a WC, countertop lavatory unit, mirror, double spindle toilet paper holder, paper towel dispenser, grab rod, sanitary napkin receptacle, liquid soap dispenser, and waste receptacle.

2.4.4.3 Sanitary Facilities Serving Medical and Dental Spaces and Battle Dressing Stations.

a. One or two baths or two community sanitary spaces shall be provided as required to support the number of berths and mixed gender occupancy in the medical ward being served. Direct access shall be provided to the bath(s) or community sanitary spaces from the medical ward. In each bath or community sanitary space, at least one WC shall be outfitted with a flexible hose and hand controlled spray nozzle with wall bracket and be connected to hot and cold water.

b. Baths shall be provided to serve Intensive Care Units and Quiet Rooms in the Medical Complex or the Medical Treatment Room (MTR) on ships with a ward integral to the MTR. These baths shall be outfitted with a hamper, and a patient call system shall be installed. The WC in these baths shall be outfitted with a flexible hose and hand controlled spray nozzle with wall bracket and be connected to hot and cold water.

c. Scrub sinks supporting medical operating rooms shall be foot-operated.

d. Battle Dressing Stations (BDS), Auxiliary BDS, Triage, Pre-Op, and Medical Treatment rooms shall be equipped with a foot-operated surgeon's lavatory sink with instrument trays.

e. Exam/Consultation rooms shall be equipped with a surgeon's lavatory sink with instrument trays and a 6-inch wrist blade, gooseneck faucet.

f. A 6-inch wrist blade, gooseneck faucet shall be provided for all remaining sinks located in spaces where patient care is provided.

g. All other sinks in medical and dental spaces shall be service sinks.

h. With the exception of sanitary spaces, foot-operated soap dispensers shall be provided for all sinks in medical and dental spaces.

2.4.4.4 Sanitary Spaces Serving the Brig. On ships equipped with a brig facility, fixtures shall meet Bureau of Personnel (BUPERS) requirements and use 804-5959213 to ensure protection of prisoners and guards.

2.4.5 Sanitary Requirements in Food Service Spaces. Food service spaces shall be in accordance with the following:

a. Hand wash sinks shall be strategically located in food preparation, utensil washing, and scullery areas. Each hand wash sink shall be supplied with a single lever pop-up drain stopper, drain overflow, hot and cold potable water, soap and paper towel dispensers, and a waste receptacle. Hand wash sinks shall be installed so that personnel shall walk no more than 25 feet or pass through a normally closed door to reach a hand wash sink. Where soiled items are handled in utensil and scullery areas, these sinks may be used. In clean dish and utensil areas, separate hand wash sinks shall be required to avoid contamination of clean items.

b. Each galley, vegetable preparation room, and scullery without an integral built-in cleaning gear locker shall be provided with a hot and cold potable faucet with a hose connection.

c. Cold potable water shall be provided at each vegetable preparation area.

2.4.6 Laundries. A service sink supplied with hot and cold potable water hose, bib type faucet, soap and paper towel dispensers, and waste receptacle shall be provided for a full service laundry space and each self-service laundry space.

2.4.7 Workshops. Where workshops require a service sink, soap and paper towel dispensers and a waste receptacle shall be provided.

2.4.8 Cleaning Gear Locker. Cleaning gear lockers shall be in accordance with the following:

a. Built-in cleaning gear lockers shall be provided with a hot and cold, bib type, self-closing faucet for filling a bucket, approximately 24 inches above the deck, and a deck pan with drain. A service sink, supplied with hot and cold fresh water, may be provided in lieu of a bib type self-closing faucet and deck pan with drain. A swab and broom rack, bulkhead-mounted soap and paper towel dispensers, and shelving shall be installed within built-in cleaning gear lockers. Shelving shall be 15 inches deep, spaced 12 inches vertically with the first shelf 50 inches above the deck. Built-in cleaning gear lockers shall have a louvered door.

b. A built-in cleaning gear locker shall be provided in or adjacent to a community sanitary space. Where space constraints prevent the built-in cleaning gear locker, a bulkhead-mounted faucet and deck pan may be installed at a convenient location within the sanitary space. A small locker shall be provided nearby for the storage of cleaning gear.

c. Built-in cleaning gear lockers shall be provided within each fire zone on every deck for cleaning of offices, passages, workspaces, food service areas, staterooms/bunkrooms with T/S spaces, deck WR/WC spaces, service spaces, and command and control spaces. These may be provided within, or adjacent to, a local deck WR/WC space. Additional built-in cleaning gear lockers shall be provided within a particular fire zone, where several contiguous spaces have a total of not more than 75 accommodations or where major passages are not connected. A single built-in cleaning gear locker may serve that group of spaces. Built-in cleaning gear lockers shall be provided on the basis of 1 for every 20 staterooms/bunkrooms or fraction thereof.

2.4.9 Major Sanitary Fixtures.

2.4.9.1 Lavatories (Washbasins). Lavatories (washbasins) shall be in accordance with the following:

- a. At least one lavatory shall be provided in each WC space.
- b. Lavatories shall be located so that, when in use, personnel face forward or aft.
- c. Each lavatory shall be provided with rounded or sloping bottoms for drainage in all trim conditions, a drain overflow, and a faucet supplied with both hot and cold potable water.
- d. Continuous-countertop type lavatories in washrooms and washroom areas shall be spaced 24 inches center-to-center when two or more adjacent sinks are provided in a row.
- e. A mirror made of laminated glass, toiletry shelf, lighting fixture, and two ground fault circuit interrupter (GFCI) type electrical outlets shall be provided for each lavatory. Mirrors shall extend the full length of the countertop installation, but shall be segmented to facilitate replacement. Complete, easy access to lavatory plumbing for cleaning, maintenance, and damage control shall be provided. Polycarbonate mirror may be used in place of laminated glass in community sanitary spaces, deck WR/WC, and baths.
- f. A lavatory unit shall be provided in each officer stateroom or bunkroom when served by a T/S space or a community sanitary space. A second lavatory unit shall be provided in eight-person transient officer bunkrooms.
- g. A lavatory unit shall be provided in each CPO/SNCO or Crew/Troop bunkroom when served by a T/S space; otherwise, a lavatory unit is not required in the bunkroom when served by a community sanitary space.

2.4.9.2 Water Closets (WC or Toilets). Water closets (WC or toilets) shall be in accordance with the following:

- a. Toilets for a gravity drain system, when provided, shall be oriented to minimize siphoning effect on traps due to ship motion.
- b. In community sanitary spaces, and multiple user semi-private T/S spaces, WC shall be enclosed in a cubicle, with a privacy door. The minimum cubicle size shall be 30 inches wide by 30 inches deep (door to front of WC) or greater for both single- and double-door installations.
- c. Partitions shall be CRES, and smooth sided for durability and easy cleaning. Partitions shall be entirely supported from the overhead and bulkheads to simplify deck maintenance, and no more than 14 inches above the deck.
- d. For a standard enclosure, provide a single door opening inward. Locate the door at the end or side of the enclosure, and provide a spring-loaded hinge set to hold it open except when latched from inside. The privacy door shall be self-opening and lockable. A coat hook shall be provided on the inside of the door centered near the top. Where a standard door enclosure cannot be provided, a double door may be installed.

e. Each WC enclosure shall also have a toilet paper holder, open front toilet seat, and sanitary napkin disposal container. In sanitary spaces serving living spaces, the sanitary napkin disposal container shall be removable when not needed (such as when the living space is used by males).

2.4.9.3 **Showers.** Showers shall be in accordance with the following:

a. Showers shall be of the individual stall type with privacy curtain and curtain rod. Minimum size shall be 30 inches wide by 30 inches deep with CRES joiner bulkheads and CRES partitions. In community sanitary spaces, showers shall be grouped around a common shower drying area and separated from washroom and water closet areas. A partial door or partition with an open area at the bottom or a full door with ventilation louvers at the bottom shall be provided at the access to the shower drying area to assist in controlling heat and humidity.

b. Each shower and drying area shall be provided with a watertight coaming with deck covering sloped toward a deck drain.

c. Showers shall not be located against any bulkhead, structure, shell, or deckhouse adjacent to the weather or ship exterior.

d. A grab rod and soap and shampoo shelf shall be provided in each shower stall.

e. Where practicable, shower heads shall not be placed opposite the shower curtain or door; but instead, shall be placed on the partition or bulkhead perpendicular to the shower curtain or door.

2.4.10 **Accommodations per Major Fixture.** The numbers of accommodations to be served per major fixture in a community sanitary space are shown in Part I, [Table 2-3](#). Calculations for each community sanitary space are to be based on the accommodations locally served by that space. If the result, when the number of accommodations is divided by the “accommodation per fixture” factor is not an integer, then the number of fixtures shall be the next highest integer. Community sanitary spaces, if provided in the medical ward, shall also use Part I, [Table 2-3](#) for the accommodations per enlisted crew/troop fixture.

Table 2-3. Number of Accommodations per Fixture for Community Sanitary Spaces.^{1/}

Fixture	Officer Ship/Troop	CPO/SNCO	Enlisted Crew/Troop
Lavatories	30 ^{2/}	8	15
WCs ^{3/}	8	10	14
Showers	11	12	25

NOTES:

- ^{1/} Paper towel dispensers shall be provided in each space. These may be augmented by electric hand dryers, but not to the extent of exclusion of paper towel dispensers.
- ^{2/} One lavatory unit with built-in washbasin, toilet case, mirror, light, and receptacle shall be provided in each officer stateroom when not provided with a bath.
- ^{3/} A second WCs shall be added beginning at the seventh accommodation.

2.4.11 **Fittings and Miscellaneous Accessories.** Fittings and miscellaneous accessories, as listed in Part I, [Table 2-4](#), shall be provided in sanitary spaces serving the berthing compartments and in staterooms and bunkrooms where lavatories are provided. Fittings and miscellaneous accessories apply to deck WR/WC spaces in Part I, [Table 2-4](#) where requirements apply to “WC” and “lavatory” and to “sanitary space”.

Table 2-4. Fittings and Miscellaneous Accessories for Sanitary Spaces.

Item	Description
Faucets	One per lavatory ^{1/}
Tumbler and toothbrush holder	One per officer bath or private T/S space
Mirror	One per lavatory ^{2/}
Paper towel dispenser	One per sanitary space ^{3/}
Sanitary napkin receptacle	One per WC
Shower grab rod, 12 inches wide	One per shower stall
Shower assembly	One per shower stall
Soap and shampoo shelf	One per shower stall
Soap dish	One per officer lavatory ^{4/}
Liquid soap dispenser	One per two lavatories or fraction thereof
Toilet article case	One per officer lavatory
Toiletry shelf	One per lavatory where toilet article case is not provided
Toilet paper holder	One per WC, double roll spindles
WC	With open front seat and compatible with the vacuum or gravity drain system
Towel hook	One per shower stall ^{5/}
Towel rod	One per person in sanitary space or in living space
Trash receptacle	One per sanitary space, removable bulkhead-mounted unit, where arrangements permit
Shower curtain	One per shower stall
Shower curtain rod	One per shower stall
Hand dryer, electric	Optional for surface ships
NOTES:	
^{1/} Commercial grade, single lever with pop-up drain stopper.	
^{2/} The bottom of the mirror (laminated glass or polycarbonate) shall be installed 13.5 inches above the lavatory countertop.	
^{3/} In community sanitary spaces, 1 per 24 accommodations or fraction thereof.	
^{4/} Liquid soap dispenser may be used in lieu of soap dish in officer lavatory.	
^{5/} Towel hooks shall be located 77 inches above deck.	

2.4.12 **Design and Construction Considerations.** Design and construction shall be in accordance with the following:

- a. Consideration should be made to arrange spaces to affect line up or grouping sanitary facilities to help in minimizing piping leads, such as lining up sanitary spaces vertically between decks.
- b. Plumbing fixtures shall be grouped to minimize the number of piping leads and penetration of structural decks, bulkheads, and shell plating.
- c. The design and arrangements of each type of sanitary space (community sanitary spaces, baths, private T/S, semi-private T/S, and deck WR/WCs) shall be consistent throughout the ship to the maximum extent possible.

d. Sanitary spaces may be made from standardized, pre-fabricated piece parts and then assembled on the ship or may be made from modular, pre-outfitted commercial marine units. If modular units are used, NAVSEA review and approval is required.

e. The following requirements apply when modular sanitary units are used:

(1) Modular sanitary units shall be furnished complete with all fixtures, fittings, and accessories, as necessary.

(2) Modular sanitary units shall have external connections for hot and cold potable water supply, gray and black water drain collection, electrical supply, and ventilation supply/return.

(3) Modular units shall be fabricated using materials that meet the fire performance requirements of MIL-STD-1623.

(4) Modular units shall have adjustable legs, or other means of leveling adjustment, for deck-mounted installation.

(5) The piping system for potable water supply and drains, and the vent system, shall be arranged and grouped for ease of connection to the ship's systems and concealed behind removable bulkhead and ceiling panels where such panels are installed. Portions of the piping systems, which directly connect to the sanitary fixtures, may be exposed between the bulkhead panel and the fixture mounted thereon.

(6) The deck of modular sanitary units shall be sloped toward the drain. The void under the modular deck shall be accessible for inspection, maintenance, and repair.

2.5 FOOD SERVICE SPACES.

2.5.1 **General.** This section contains requirements for designing and equipping food preparation spaces, food serving stations, messrooms, provisions storage/issue rooms, meat thaw room, sculleries, and scullery areas. For more specific guidance on arrangement and outfitting of food service spaces, including provisions stowage/issue rooms and meat thaw room, see Part II, [Chapter 7](#). All surfaces shall be capable of being easily cleaned and shall be impervious to damp conditions or moisture absorption. Access shall be provided to all areas requiring cleaning, painting, or treating with pesticide/insecticide. Food service areas shall be protected against leakage or seepage of lubricants or other extraneous or foreign substances. There shall be no crevices or inaccessible voids which may harbor vermin, cooking or food waste, or other extraneous matter. Distributive systems such as piping, wiring, and HVAC ducts in food service areas shall be moisture-tight or within moisture-tight enclosures. Deck drains shall be provided in all food service areas subject to flood-type cleaning. Deck drains for food service areas shall be provided in a sufficient number and location so that complete drainage is possible under normal conditions of list and trim.

2.5.2 **Food Service Equipment.** Only Navy approved shipboard food service equipment shall be selected based on one or more of the following requirements:

a. U.S. Navy Food Service Equipment Catalog S6161-Q5-CAT-010 (see <http://usnhabeqptcatalog.gdit.com/>).

b. NAVSEA type or standard drawing.

c. Food service equipment not listed in U.S. Navy Food Service Equipment Catalog S6161-Q5-CAT-010 (see <http://usnhabeqptcatalog.gdit.com/>) may be submitted for consideration and approval prior to procurement and installation by NAVSEA and the Habitability LCM and added to the catalog. Equipment design, testing, and evaluation shall be accomplished by a designated Navy approved facility.

Food service equipment shall be tested to validate specified operation after installation. Tests shall be conducted in accordance with applicable Federal, Military, or ASTM specifications and standards. Equipment shall operate satisfactorily without malfunction or abnormalities.

2.5.3 **Doors in Food Service Spaces.** Doors in food service spaces shall be in accordance with the following:

a. Doors to food service spaces shall be easily cleanable and shall be fabricated as to be free of inaccessible openings or slots. If gaskets are used on insulated doors, they shall be easily cleanable, replaceable, and should be tightfitting. The door width to messroom shall be at least 36 inches; for the galley and pantry, at least 30 inches. Joiner doors in mess and galley areas shall be provided with CRES push and kick plates.

b. Doors to deck WR/WCs serving messdeck areas shall be self-closing.

c. Double swing doors are only to be used in bulkheads between a food preparation space, such as a galley or pantry, and a messroom or dining room.

2.5.4 Messroom Design Requirements. Design requirements of messrooms shall be as follows:

- a. In addition to the primary function, all messrooms shall be designed to support recreation (including movies) and training, as well as their primary messroom function.
- b. Messroom access shall be designed to prevent personnel in the mess line from standing on the weather decks, and from passing through visible garbage disposal areas while progressing through the serving line.
- c. Beverage service stands shall be designed according to 804-6983470. The space under each beverage service stand shall be provided with CRES shelving spaced for the stowage of condiments. Shelves shall be ribbed with CRES flat bars as required to retain condiments against ship motion. The top shall be provided with a continuous spillage trap configured to catch the spillage from all dispensing equipment. The front of stands shall be provided with hinged doors with a positive latching device. Each stand shall be sufficient in size to mount the beverage equipment specified. Length of stands shall accommodate the quantity of equipment indicated on the drawing with a 6-inch minimum clearance between and under the equipment for cleaning and ventilation of the equipment. Service stand tops shall be 34 inches above the finished deck. Service stand tops shall be reinforced underneath to support a minimum load of 150 lb/ft² for supporting the selected equipment. A CRES tray slide shall be provided as shown in 804-6983470.
- d. In ships that are smaller than destroyers/frigates, personnel grouping for messing purposes shall be considered on a case basis, providing for separate officer messrooms and CPO messrooms wherever possible. In amphibious ships, messrooms for troop officers, SNCOs, and other enlisted shall be combined with those provided to their ship's company counterparts. In ships designed to accommodate Flag Officers, separate flag messrooms shall be provided.
- e. Non-slip type deck covering shall be supplied where occasional water, oil, or liquid on the deck is expected.
- f. Messrooms shall be located apart from berthing areas, be adequately ventilated, be adequately insulated to prevent condensation or overheating, and be located as near to the galley as is practicable.
- g. Where a messroom area is also designated as a weapons assembly area, a means shall be provided to secure tables and other equipment to the deck that can easily be removed when needed. Stowage shall be provided for these items when removed.

2.5.5 Messroom Furniture Sizes and Clearances. Messroom furniture shall be in accordance with the following:

- a. The height of messroom tables shall be between 28 inches and 30 inches. The clearance between the seat and the bottom of the table structure shall be at least 7 inches. The depth of tables for facing diners shall be at least 36 inches for officers and CPO and at least 27 inches for crew/troop.
- b. Crew/troop messrooms shall be designed on the basis of 24-inch table space width per seat.
- c. Officer and CPO messrooms shall be designed on the basis of 27-inch table space width per seat.

2.5.6 Messroom Outfitting. Messrooms shall be in accordance with the following:

- a. Tray slides (or rails) shall be provided along food and beverage serving lines. A transparent sanitation shield (sneeze shield) shall be installed to completely shield the entire length of food serving lines above the tray rail, allowing for space between the bottom of the shield to the top of the serving area required for self-serve. The distance between the bottom of the sanitary shield protecting the food and the top of the tray slide shall be at least 18 inches. Tray slides shall be installed at dresser height and shall be configured with either a solid flat top or tubular rails approximately 11 inches deep, installed flush to countertop sill, to accommodate any size cafeteria serving tray. Brackets for supporting tray slides shall be CRES and shall be capable of supporting 200 pounds at the point of maximum moment. Collapsible tray slides shall be provided where the maximum passage width is required during non-meal periods.
- b. One electronic marquee digital menu board shall be provided at the head of each food serving line.
- c. Dispensers shall be provided for stowing and dispensing dishes, bowls, trays, cups, glasses, and silverware on the messdeck. Dispensers shall be provided for a minimum of 65 percent of crew accommodations for FORCE PROJECTION ships (carriers and L-Decks), and 90 percent for combatant ships/crafts. Dispensers shall be located adjacent to the serving line on the approach side of the serving counter, except that cup, glass, and silverware dispensers shall be located at the exit end of the serving counter or adjacent to the beverage service stand.
- d. Adequate stowage of condiments shall be provided in messrooms.

2.5.7 Clearance in Messrooms. Walking areas providing access to and within messrooms and wardrooms shall be in accordance with the following requirements:

- a. Where queues for food serving lines could form and are part of the main access walking area, they shall be clear of obstructions and not less than 48 inches in width.
- b. Minimum unobstructed clearance for main walking areas passing through the messroom shall be 36 inches.
- c. Where consumables are dispensed (including, but not limited to, beverage service stands/counters, vending machines, soup and salad bars, or dessert stations) or where soiled trays or dishes are disposed of shall be not less than 48 inches wide.
- d. Minimum unobstructed clearance (i.e., between table edges) for secondary walking areas shall be 30 inches.
- e. For tables with removable chairs, the distance between adjacent tables where personnel are seated shall be 60 inches. The distance between such tables and adjacent bulkhead or structure shall be 42 inches. For tables with fixed outrigger type seating, back-to-back clearance between seat backs at adjacent tables, and between seat backs and adjacent bulkhead or structure, shall be not less than 24 inches.
- f. Deck area requirements for planned seating capacity shall be at least 10.8 square feet per seat.
- g. The width of serving aisles, measured from service counter or outside edge of tray rail if present, shall be at least 36 inches.

2.5.8 Messroom Seating.

2.5.8.1 Crew/Troop Messrooms. The number of mess seats provided, as a minimum, shall be in accordance with Part I, [Table 2-5](#).

Table 2-5. Crew/Troop Mess Seats.

Ship type	Crew mess seats as a percentage of accommodations
Amphibious	15
Aircraft carrier	14
All others	30

2.5.8.2 Officer and CPO/SNCO Messrooms. The number of mess seats provided shall be in accordance with Part I, [Table 2-6](#). In amphibious ships, the number of mess seats in the respective messrooms of ship/troop officers and CPOs/SNCOs shall be as specified in [Table 2-6](#) as a minimum. In aircraft carriers, seats shall be as specified in [Table 2-6](#), as a minimum, for officer and CPO accommodations in their respective messrooms. The Flag and Commanding Officer shall be provided with a separate mess.

In all other surface ships, the number of officers and CPO mess seats, in their respective messrooms, shall be as specified in [Table 2-6](#), as a minimum. Telephone or other internal communications shall be provided in the officer's mess.

Table 2-6. Officer and CPO/SNCO Mess Seats.

Number of accommodations	Mess seats
Amphibious: any	80% Ship's company element or 40% combined Ship's company and Troop element accommodations, whichever is larger
Aircraft carrier: any	40%
All other surface ships: 0 – 20	80% x N
All other surface ships: 21 – 50	16 + 70% x (N – 20)
All other surface ships: 51 or more	37 + 60% x (N – 50)
NOTE: N – Number of accommodations	

2.5.9 Galley.

2.5.9.1 **General.** Galleys shall be in accordance with the following general design criteria:

- a. Centralized galleys shall be provided for officers, CPOs/SNCOs, and enlisted crew/troops.
- b. Materials used shall resist stain and corrosion. Where aluminum alloys are specified in this section, they shall be in accordance with ASTM B209, Alloy 5052. CRES shall be AISI Type 304, Finish 4. Nickel-copper alloy shall be satin-finish in accordance with ASTM B127. Food service equipment of the same type and size shall be the product of a single manufacturer. Sizes and quantities of equipment for the galley shall support the specific numbers of accommodations onboard the vessel and required Navy Standard Core Menu. All food service equipment for U.S. Navy vessels shall be selected from U.S. Navy Food Service Equipment Catalog S6161-Q5-CAT-010 (see <http://usnhabeqptcatalog.gdit.com/>.)
- c. Food service equipment cited by ASTM designation shall be in full compliance with the supplemental requirements for naval shipboard use.
- d. All spaces in which food is prepared or stored shall be ventilated sufficiently to be reasonably free of disagreeable odors and condensation. Protective shields shall be provided at hot and cold hazards.
- e. Raw meat preparation areas shall have sufficient physical separation to protect ready-to-eat preparation areas from contamination.
- f. Containers used to receive and store garbage shall be watertight, easily cleanable, and non-absorbent. Ventilation hoods shall be designed to prevent grease or condensation from dripping into food or onto food preparation surfaces.
- g. Washbasin facilities of suitable design and the following characteristics shall be provided for food service personnel:
 - (1) Located so that no crew member must walk more than 25 feet to a station. Service sinks and scullery sinks are not satisfactory hand washing stations.
 - (2) Positioned so that crew members do not have to squat or reach excessively to wash hands at hand washing station.
 - (3) Located so that crew members do not have to travel through a door to reach a hand washing station.
 - (4) Facilities in the galleys shall have mixing taps that can be operated without the use of hands.
- h. Provide one faucet for no more than two kettles, or fraction thereof, and a deck-mounted food mixing machine. The faucets shall be located at a suitable height for filling mixing bowls and kettles. Faucets for kettles shall be located where structure and arrangements permit to ensure more than one kettle can be served.
- i. Corners formed in flashings, closure plates, shields, or sheathing shall be rounded. All exposed surfaces shall be easily accessible for cleaning. Joints shall be tight. Fasteners, where used, shall be simple to clean and free of snags. Expanded metal or perforated metal shall not be used as flashing strips. Where air circulation is required, louvered metal may be used.
- j. Dressers shall be provided in galley food service areas to the maximum extent possible. Dresser tops shall be 0.109 inch thick CRES and shall be adequately reinforced to support dresser-mounted equipment and to prevent excessive vibration when equipment is operating. Dressers shall be constructed in accordance with 804-6983471. A minimum of

4 square feet of dresser space shall be allocated for each oven cavity, skittle, griddle, meat slicer, mixer, vegetable chopper, each 10-gallon capacity of kettles, and any other functional piece of galley equipment.

2.5.9.2 **Outfitting.** The type and quantity of equipment selected and arrangement of equipment in food service spaces shall be in accordance with guidance provided in Part II, [Chapter 7](#) and shall be under the cognizance of Naval Surface Warfare Center Philadelphia Division (NSWCPD) and Naval Supply Systems Command (NAVSUP).

2.5.9.3 **Potable Water.** Potable hot and cold water shall be easily accessible in all rooms where food is prepared. Only potable water shall be piped to food storage, preparation, or service areas.

2.5.9.4 **Ice Making Facilities.** Ice making facilities capable of furnishing at least 3.0 pounds of ice per accommodation per day shall be provided. Ice making machines shall be located on the messdeck area (beverage line) with capacities proportional to the number of personnel served in each mess. The total available capacity shall be split 60 percent/40 percent between beverage line dispenser supply and securable bulk ice supply. Bulk ice supply is that needed for other than beverage line dispenser supply (such as medical, galley food service, and other general uses). Separate ice making facilities shall be provided when a medical ward is provided.

2.5.9.5 **Drains.** Deck scupper drains shall be a minimum of 2.5 inches in diameter. There shall be no deck drains inside provision issue rooms except the thaw room. Horizontal drain lines shall be not less than 4 inches above the deck.

2.5.9.6 **Maintenance/Cleaning.** Maintenance and cleaning equipment and areas shall be in accordance with the following:

- a. Cutting boards shall be readily removable for cleaning or easily cleanable in place.
- b. Drawers and bins used as food contact surfaces shall be readily removable and easily cleaned.
- c. Covers, insets, or receptacles for unpackaged foods or beverages shall be easily removable or designed for easy cleaning in place.
- d. Stovetop or range sea rails shall be readily removable and easily cleanable, and brackets for sea rails shall be easily cleanable.
- e. Ventilation baffles, vanes, louvers, dampers, filters, etc., shall be easily accessible or removable (without tools) for cleaning.
- f. All deck-mounted equipment shall be elevated on legs that extend not less than 8 inches above the finished deck to allow for cleaning or elevated on an enclosed foundation that extends not less than 6 inches above the finished deck. When the space under the equipment is enclosed, it shall be sealed by a corrosion resistant steel subbase, and watertight at both top and bottom; where the design of the equipment precludes a tight seal at the top of the subbase, the space within the subbase shall be filled with lightweight concrete. Ovens shall be leg mounted for air circulation and cleaning purposes.
- g. Table-mounted equipment, unless easily movable, shall be either sealed to the table top or mounted on legs not less than 6 inches above the table top when overhead clearance permits, but not less than 4 inches above the table top to allow cleaning.
- h. Equipment shall be designed to be operated, maintained, and repaired from the front in order to minimize total ship area and volume requirements and to facilitate maintenance where possible.

2.5.9.7 **Galley Dimensional Aspects.** Galley dimensions shall be in accordance with the following:

- a. Clearances between adjacent equipment or between equipment and a bulkhead shall be, as a minimum, what is recommended by the equipment manufacturer for their equipment.
- b. Food preparation counters and cabinets shall be between 16 inches and 24 inches deep and approximately 36 inches above the deck.
- c. Kick space (4 inches high by 4 inches deep) shall be provided around cabinets, counters, etc.
- d. Storage cabinets installed above food preparation counters and dressers shall be:
 - (1) A minimum of 14 inches above the counter.
 - (2) A maximum of 12 inches deep.
 - (3) Less than 72 inches above the deck.
 - (4) Less than 56 inches above the deck if direct vision of the contents is required.
- e. Food dressing tables accessible from both sides shall be at least 60 inches wide.

- f. Tops of food dressing tables, counters, and drain boards shall be constructed with 12-inch high integral splashbacks.
- g. Uncovered water sources, such as water contained in sinks, shall be located at least 48 inches from equipment having external cooking surfaces, such as griddles and ranges.
- h. Small jacketed kettles mounted on dressers shall be installed with the height of the rim of the kettle not more than 46 inches above the finished deck.

2.5.9.8 Dry, Freeze, and Chill Provision Storerooms, Provisions Issue Room, and Meat Thaw Room Supporting Galley. See Part I, 4.1 for requirements on dry, freeze, and chill provision storerooms, provision issue room, and meat thaw room. Dry, freeze, and chill provision storerooms shall be in accordance with the following:

- a. Dry, freeze, and chill provision storerooms shall be consolidated in close proximity to the galley in the same vertical zone, if possible, or if below the galley, not more than one deck below and clustered in the same area as the galley with elevator access to the galley to accommodate material handling. Doors to dry, freeze, and chill provision storerooms shall be at least 60 inches wide by 80 inches high, open 180 degrees, and permit movement of a 44-inch by 54-inch pallet through the opening into the dry, freeze, and chill provision storeroom to accommodate automated material handling equipment.
- b. There shall be a “locked-in” alarm in each freezer and cold storage room. It shall be possible to open the doors of the refrigerated or cold storage rooms from the inside even though they lock from the outside. Light switches for lights inside the cold rooms shall be mounted on the outside bulkhead adjacent to the handle side of the door.
- c. Exposed refrigerant coils, blower or fin type evaporators, and water coils shall be easily accessible for cleaning. Exposed refrigerant coils, blower or fin type evaporators, and water coils shall be enclosed or shielded to protect them from food spillage.
- d. Refrigerators for the storage of food shall be capable of maintaining a temperature within 32 to 41 °F at all times. The temperature of the freezer shall be 0 °F or lower. A non-mercury thermometer shall be placed in the center of each refrigerator and freezer. The thermometer shall be readily observable, easily readable, numerically scaled, and accurate to ± 3 °F at the critical range. There shall be an alarm in each freezer and chill storeroom to warn when the temperature is out of specification.
- e. Each freezer and refrigerator shall have the capacity to assume the function of the other, i.e., freezer to chill or vice versa. The utilization of chill space for freeze is to provide flexibility for contingencies.
- f. There shall be a control panel outside each freezer and cold storage room.
- g. Deck drains shall be provided in freeze and chill provision storerooms in accordance with NAVSEA-approved specifications.

2.5.9.9 Scullery.

- a. General. General design criteria shall be in accordance with the following:
 - (1) Materials used shall resist stain and corrosion. Where aluminum alloys are specified in this section, they shall be in accordance with ASTM B209, Alloy 5052. CRES shall be AISI Type 304, Finish 4. Nickel-copper alloy shall be satin-finish and in accordance with ASTM B127. Scullery equipment of the same type and size shall be the product of a single manufacturer. Sizes and quantities of equipment for the scullery shall support the specific numbers of accommodations onboard the vessel. All scullery equipment for U.S. Navy vessels shall be selected from the U.S. Navy Food Service Equipment Catalog S6161-Q5-CAT-010 (see <http://usnhabeqptcatalog.gdit.com/>).
 - (2) All spaces in which utensils are washed shall be ventilated sufficiently to be reasonably free of disagreeable odors and condensation. Protective shields shall be provided at hot and cold hazards.
 - (3) Containers used to receive and store garbage shall be watertight, easily cleanable, and non-absorbent.
 - (4) Wherever possible, the pot scrubbing function and the dish washing function shall be combined in the scullery to reduce manpower. The scullery operation shall be located within or in close proximity to the galley to maximize manpower while conforming to the highest sanitation requirements.
 - (5) Scullery shall be designed or insulated to minimize transmitting noise to adjacent spaces.
- b. Outfitting. A clear space of 8 inches shall be provided under each piece of deck-mounted equipment except for equipment with bedplate bases. Equipment shall be installed parallel to the baseline.
 - (1) Pot/Pan/Utensil Wash Area.

(a) Utensil wash dressers shall be provided with a 2-inch high retainer edge and a 12-inch high splashguard. The retainer edge shall be provided with an apron that extends down in the same manner as for other dressers. The utensil wash dresser shall be provided with four sinks sequentially oriented and labeled: GARBAGE DISPOSAL SINK; WASH SINK; RINSE SINK; SANITIZING SINK. The sinks shall be installed in the same sequential order (left-to-right) or (right-to-left) to support the logical process of cleaning (i.e., from receipt of dirty dishes/utensils to final clean dishes/utensils for drying). All sinks shall be 18 inches front-to-back and 24 inches left-to-right by 18 inches deep (except sanitizing sink shall be 26 inches deep) with a CRES perforated 0.5-inch (inside diameter) tube welded into the back corner of each sink well (except garbage disposal sinks) to accept the water temperature probe. Sinks shall be oriented in the dresser tops with the short side to the front of the dresser (operator side). The sanitizing sink shall be provided with a sink booster heater and a perforated CRES sanitizing dip basket. The dip basket shall be sized to fit inside the sanitizing sink and shall be provided with handles that protrude 3 inches from the top of the dresser. The pot/pan/utensil wash area shall have sufficient racks and storage area to permit air drying.

(b) A pot, pan, utensil wash machine shall be provided for large deck ships.

(2) Dishwashing. A dishwashing machine, along with a dump/scrap sink and pre-wash spray hose, shall be provided. The dishwashing machine installation shall meet the following:

(a) Maintain a machine wash water temperature within the range of 140 to 160 °F.

(b) Provide water supply at 15 to 25 pounds of flow pressure on the final rinse line at the machine, and not less than 10 psi.

(c) Provide water-heating facilities to maintain a minimum final sanitizing rinse temperature of 180 °F and a maximum final sanitizing rinse temperature of 195 °F in the final wash-water rinse line.

(d) Provide sufficient racks and clean utensil storage area to permit air drying (i.e., 15 seconds) before removal of utensils from racks following washing.

(e) Provide an easily readable thermometer for each tank and final rinse-water line.

(f) Double tank and flight type dishwashing machines shall be oriented normal to the predominant ship motion.

(3) Trash Receptacles. Sufficient trash receptacles shall be provided in the vicinity of the scullery for segregating the different types of trash such as aluminum, plastics, paper, etc.

c. Potable Water. Potable hot and cold water shall be easily accessible in all rooms where utensils are cleaned. Only potable water shall be piped to service areas. The grinder deliver line shall be protected against back flow. Hot and cold potable water shall be available in garbage rooms for washing garbage cans.

d. Drains. Deck scupper drains shall be a minimum of 2.5 inches in diameter. Drainage gutters for flood cleaning of decks shall be easily accessible for cleaning. Cover plates installed over drainage gutters shall be easily removable. Horizontal drain lines shall be not less than 4 inches above the deck.

e. Maintenance/Cleaning. Maintenance and cleaning equipment and areas shall be in accordance with the following:

(1) Ventilation baffles, vanes, louvers, dampers, filters, etc., shall be easily accessible or removable (without tools) for cleaning.

(2) All deck-mounted equipment shall be elevated on legs that extend not less than 6 inches above the finished deck to allow for cleaning.

(3) Equipment shall be so designed to be operated, maintained, and repaired from the front in order to minimize total ship area and volume requirements and to facilitate maintenance where possible.

2.5.9.10 Solid Waste Processing Equipment. Equipment required for processing of food and solid wastes generated from food service and other habitability related spaces is not covered in this document.

a. For guidance on solid waste equipment and spaces, see S9593-C6-IIN-010. Solid waste processing equipment includes pulpers, solid waste shredders, plastic waste processors, and incinerators.

b. For guidance on food waste disposers (garbage grinders), see 593-7556875.

2.6 LEISURE AND COMMUNITY.

2.6.1 General. The design philosophy shall be to provide sufficient space, exclusive of messrooms, for one-third of accommodations to simultaneously participate in lounge, recreation, physical fitness, and welfare activities. The purpose is to allow for a change of environment from watchstanding and working routine during off-duty hours. Each of the five activities listed below shall be accommodated in compartments assigned exclusively to each of these functions.

- a. Lounge Facilities. To satisfy personal needs for passive, quiet pursuits and personal entertainment such as reading, writing, off-duty education, listening to music, and watching television, as well as holding meetings or conducting other ship's business as needed.
- b. Recreational and Physical Fitness Facilities. To satisfy personal needs for active pursuits such as hobbies, playing games, watching television, physical fitness, and more active social and competitive events.
- c. Library Multimedia Resource Center (LMRC). For personal advancement and leisure purposes. The center provides a collection of reading and listening materials, lending and the use of instructional materials, and entertainment media in printed, recorded, and digital format, including internet access.
- d. Training Facilities. For instruction in qualification for promotion, personal skills, trades, professional careers, ship procedures, etc.
- e. Religious Ministry. Areas in which individuals may satisfy their spiritual welfare needs and attend a variety of religious services.

2.6.2 Lounge Facilities (Officer Wardrooms, CPO/SNCO, and Crew/Troop Lounge Spaces). As a minimum amount of recreation, lounge and welfare space and seating and writing space shall be provided, exclusive of messrooms and berthing spaces, as follows:

- a. Officers. A wardroom lounge shall be provided for officers. Where officer lounges are combined with their respective messrooms, the compartment arrangement shall provide maximum functional separation and utility. Seating in the wardroom lounge shall be 4 seats plus 20 percent of officer accommodations.
- b. CPO/SNCO. A lounge shall be provided for CPOs/SNCOs in the vicinity of their living spaces. Where CPO/SNCO lounges are combined with their respective messrooms, the compartment arrangement shall provide maximum functional separation and utility. Seating in CPO/SNCO lounge spaces shall be 4 seats plus 15 percent of each CPO/SNCO accommodations.
- c. Crew/Troop. Lounges for enlisted personnel shall be located adjacent to or near berthing spaces. The number of seating in crew and troop lounge spaces shall be 4 seats plus 15 percent of each crew and troop accommodation.

2.6.3 Recreational and Physical Fitness Facilities.

2.6.3.1 Recreation Space. A recreation space shall be provided on ships with 1,000 or more accommodations for more active, social, and competitive pursuits. Also, where practicable, a recreation space separate from lounge spaces may be provided on ships with less than 1,000 accommodations. Total seating for recreation spaces shall be a minimum of 1 seat per 100 crew and troop. Adequate electrical receptacles shall be provided to support recreational electronics (e.g., TVs, DVD players, Xboxes, Wii, Playstations, etc.) in recreation spaces separate from lounge spaces. An afloat recreation staff office shall be provided on all large deck ships.

2.6.3.2 Physical Fitness Facilities. All ships shall have physical conditioning equipment adequate to provide personnel with three exercise periods per week, based upon the requirements of OPNAVINST 6110.1. Physical conditioning equipment should permit aerobic, flexibility, and strength training. Surface ships with 150 or more accommodations shall be provided with one or more dedicated physical fitness facilities. Other surface ships (with less than 150 accommodations) shall have fittings for mounting and using such equipment in either multi-purpose spaces or other open spaces where its use will not interfere with other ship functions. Adequate space shall be provided for the stowage of all physical conditioning equipment. The Commander, Navy Installations Command, Deployed Forces Support branch, shall be consulted on fitness center design, changes, and equipment requirements prior to purchasing fitness equipment.

a. Definitions.

(1) Cardiovascular Conditioning Stations. Aerobic conditioning equipment for exercising the heart and lungs for cardiovascular fitness. Equipment examples include: electronic bicycles (upright and recumbent), elliptical machines, steppers, rowers, climbers, and treadmills.

(2) Ancillary Equipment. Physical conditioning equipment that is portable or stowable in nature, including jump ropes, isometric resistance devices, hand grippers, and tensioning devices.

(3) Chin-Up and Sit-Up Stations. Chin-up bars and "toe anchors" for performing sit-ups; these shall be hard-mounted to decks, bulkheads, or overheads.

(4) Strength Conditioning Stations. Anaerobic conditioning equipment for improving strength and flexibility by exercising specific muscle groups. Equipment examples include: plate-loaded equipment, variable resistance equipment, and weight benches and platforms.

(5) Navy Operational Fitness and Fueling System (NOFFS) kit. See <http://www.navyfitness.org/fitness/noffs-training/> for details on NOFFS. The NOFFS kit is a commercially available package (see <http://www.tacticalfitnessgsa.com/>) that provides exercise equipment and instructional cards that support the implementation of NOFFS.

b. Design and Outfitting. Physical fitness facilities shall be provided with the following equipment, as a minimum:

(1) The following minimum standards shall be followed by extra small commands (PCs, MCMs, LCSs, and MSCs):

(a) Cardiovascular (aerobic) equipment as specified in Part I, 2.6.3.2.c with 25 to 50 square feet per piece plus 10 to 15 percent additional space for personnel movement.

(b) Strength equipment area shall be 75 to 150 square feet.

(c) One small multi-station machine, stand-alone, or bulkhead-mounted that includes as many muscle groups as possible.

(d) One set of urethane dumbbells 5 to 100 pounds with stand or rack.

(e) One adjustable bench for dumbbells.

(f) NOFFS kits that can be used to exercise muscle groups not included in the multi-station machine. There shall be 15 NOFFS kits.

(2) The following minimum standards shall be followed by medium commands (CG and DDGs):

(a) Cardiovascular (aerobic) equipment as specified in Part I, 2.6.3.2.c with 25 to 50 square feet per piece plus 10 to 15 percent additional space for personnel movement.

(b) Strength equipment area should be 400 to 800 square feet.

(c) At least three pieces of circuit adjustable weight-stack machines as listed; see CNIC Afloat Standards for selection from among approved pieces.

(d) At least one plate loaded machine with weight plates as listed; see CNIC Afloat Standards for selection from among 20 approved pieces.

(e) One adjustable bench for dumbbells flat/incline/decline.

(f) Dumbbells: one complete set of 5 to 100 pounds.

(g) One dumbbell rack.

(h) NOFFS kits that can be used to exercise muscle groups that are not included in the multi-station machine. There shall be 25 NOFFS kits.

(3) The following minimum standards shall be followed by LPDs and AS Class ships:

(a) Cardiovascular (aerobic) equipment as specified in Part I, 2.6.3.2.c with 25 to 50 square feet per piece plus 10 to 15 percent additional space for personnel movement.

(b) Strength equipment area shall be 1,000 to 2,200 square feet.

(c) A minimum of seven different pieces of circuit adjustable weight-stack machines.

(d) At least 16 different pieces of plate loaded machines with weight plates as listed; see CNIC Afloat Standards for selection from among 20 approved pieces.

- (e) Three adjustable benches for dumbbells flat/incline/decline.
- (f) Dumbbells: two complete sets of 5 to 100 pounds.
- (g) Two large dumbbell racks.
- (h) NOFFS kits that can be used to exercise muscle groups that are not included in the multi-station machine.

There shall be 50 NOFFS kits.

(4) The following minimum standards shall be followed by LCC Class ships:

- (a) Cardiovascular (aerobic) equipment as specified in Part I, 2.6.3.2.c with 25 to 50 square feet per piece plus 10 to 15 percent additional space for personnel movement.
- (b) Strength equipment area shall be 1,000 to 2,200 square feet.
- (c) A minimum of seven different pieces of circuit adjustable weight-stack machines.
- (d) At least seven different pieces of plate loaded machines with weight plates as listed; see CNIC Afloat Standards for selection from among 20 approved pieces.
- (e) Three adjustable benches for dumbbells flat/incline/decline.
- (f) Dumbbells: two complete sets of 5 to 100 pounds.
- (g) Two large dumbbell racks.
- (h) NOFFS kits that can be used to exercise muscle groups that are not included in the multi-station machine.

There shall be 50 NOFFS kits.

(5) The following minimum standards shall be followed by LSD Class ships:

- (a) Cardiovascular (aerobic) equipment as specified in Part I, 2.6.3.2.c with 25 to 50 square feet per piece plus 10 to 15 percent additional space for personnel movement.
- (b) Strength equipment area shall be 1,000 to 2,200 square feet.
- (c) A minimum of six different pieces of circuit adjustable weight-stack machines.
- (d) At least four different pieces of plate loaded machines with weight plates as listed; see CNIC Afloat Standards for selection from among 20 approved pieces.
- (e) Three adjustable benches for dumbbells flat/incline/decline.
- (f) Dumbbells: two complete sets of 5 to 100 pounds.
- (g) Two large dumbbell racks.
- (h) NOFFS kits that can be used to exercise muscle groups that are not included in the multi-station machine.

There shall be 50 NOFFS kits.

(6) The following minimum standards shall be followed by LHA and LHD Class ships:

- (a) Cardiovascular (aerobic) equipment as specified in Part I, 2.6.3.2.c with 25 to 50 square feet per piece plus 10 to 15 percent additional space for personnel movement.
- (b) Strength equipment area shall be 1,375 to 3,000 square feet.
- (c) A minimum of nine different pieces of circuit adjustable weight-stack machines.
- (d) At least 19 different pieces of plate loaded machines with weight plates as listed; see CNIC Afloat Standards for selection from among 20 approved pieces.
- (e) Six adjustable benches for dumbbells flat/incline/decline.
- (f) Dumbbells: three complete sets of 5 to 100 pounds.
- (g) Three large dumbbell racks.
- (h) NOFFS kits that can be used to exercise muscle groups that are not included in the multi-station machine.

There shall be 60 NOFFS kits.

(7) The following minimum standards shall be followed by CVN (NIMITZ) and CVN (FORD) Class ships:

- (a) Cardiovascular (aerobic) equipment as specified in Part I, 2.6.3.2.c with 25 to 50 square feet per piece plus 10 to 15 percent additional space for personnel movement.

- (b) Strength equipment area should be 2,000 to 4,000 square feet.
- (c) A minimum of 10 different pieces of circuit adjustable weight-stack machines.
- (d) At least 20 different pieces of plate loaded machines with weight plates as listed; see CNIC Afloat Standards for selection from among 20 approved pieces.
- (e) Eight adjustable benches for dumbbells.
- (f) Dumbbells: four complete sets of 5 to 100 pounds.
- (g) Four large dumbbell racks.
- (h) NOFFS kits that can be used to exercise muscle groups that are not included in the multi-station machine.

There shall be 60 NOFFS kits.

c. Cardiovascular (Aerobic) Equipment Requirements. All treadmills, ellipticals, and electronic bikes shall be in Physical Readiness Test (PRT) compliance in accordance with OPNAVINST 6110.1. Physical fitness facilities shall be provided with a blend of stationary bikes, recumbent bikes, spin bikes, rowing machines, treadmills, cross trainers, and other recognized equipment per the following formula:

$\# \text{ of personnel onboard} \times 30 \times 5 \text{ divided by } 8,400^* = \text{Number of cardiovascular pieces of equipment}$

* - # of personnel on board while at sea, 30 = minutes of exercise, 5 equals # of times per week to exercise (OPNAV 6110.1 states 150 minutes a week), 8,400 = # of minutes available in a week, assuming fitness center is open 20 hours per day.

Note: As a minimum, two pieces of cardiovascular equipment shall be provided for each vessel. In the event the above formula produces a fractional result, then the number of required cardiovascular equipment shall be rounded up.

- d. Physical Fitness Facilities Outfitting. Each physical fitness facility shall be outfitted with the following items:
 - (1) Non-flammable, non-porous deck matting. Deck mats in physical fitness spaces shall be in accordance with the fire performance requirements of MIL-STD-1623 for electrical grade mats.
 - (2) One TV with audio and video player wired to the ship's entertainment system per each 500 feet of area in the space.
 - (3) Speakers wired to the ship's audio entertainment system.
 - (4) Bulkhead-mounted, shatterproof mirrors.
 - (5) Where practicable, provide an entrance/exit control desk with chair.
 - (6) A warm-up/cool down area shall be provided and include small, portable exercise mats for this purpose.
 - (7) Charts shall be provided that explain how to use the exercise equipment.
 - (8) Safety and usage rules shall be posted.
 - (9) A water fountain or cooler shall be provided within or adjacent to the fitness facility.
 - (10) Provide one TV monitor for every three pieces of cardiovascular equipment in the fitness facility.
 - (11) Develop a preventative maintenance plan based upon the recommendations of equipment manufacturers.
 - (12) Provide a clock and either a target heart rate or perceived exertion chart for the fitness floor and post instructions in self-monitoring techniques for levels of exertion.
 - (13) Provide signage informing users of the warning signs and symptoms (nausea, dizziness, chest pain) of over-exertion, exhaustion, and dehydration.
 - (14) Recreation gear storeroom for ancillary equipment. Recreation gear storeroom size shall be based on the following accommodations:
 - (a) CVNs: 100 square feet.
 - (b) LHAs, LHDs: 95 square feet.
 - (c) ASs, LPDs, LCCs, LSDs: 80 square feet.
 - (d) CGs, DDGs: 60 square feet.
 - (e) PCs, MCMs, LCSs: 10 square feet.

- e. Physical Fitness Facilities Requirements. Each physical fitness facility shall meet the following requirements:
- (1) All weight machines and cardiovascular equipment shall have 20 to 25 square feet per piece with an additional 10 to 15 percent of space for personnel movement.
 - (2) All equipment shall be of commercial grade quality.
 - (3) Equipment shall fit through, or be easily disassembled to fit through, shipboard doors and hatches.
 - (4) Height, length, and width of equipment shall be appropriate for the size of the physical fitness facilities.
 - (5) Weight bearing capacity of equipment to be sufficient to support maximum weight bearing load plus the maximum user weight of 350 pounds.
 - (6) Electrical receptacles and dedicated circuits shall be provided for each treadmill at 110 volts, 20 amps. Additional electrical receptacles shall be provided to accommodate cardio theater or additional TVs as command requests.
 - (7) Equipment shall be welded to the deck directly or indirectly (stud welded through tabs in the equipment).
 - (8) A diffused light source shall be provided to avoid focusing strong light sources directly above equipment.
 - (9) Sound levels shall be not greater than 90 decibels.
 - (10) Physical fitness facilities temperatures shall be maintained between 68 to 72 °F, humidity at 60 percent or less, and air circulation 8 to 12 exchanges per hour.

f. Strength (Anaerobic) Equipment Requirements. Strength (anaerobic) equipment shall be divided into four areas and include free weights, dumbbells, adjustable weight stacks (which include multi-stations), and plate loaded. Commands are permitted to use a combination. When space is a limitation and only one type of circuit can be used, adjustable weight stack equipment shall be used. This will ensure that beginners and personnel of all body sizes will be able to use the equipment. Additionally, more users will be able to use the equipment in a shorter period of time. The following exercises are recommended for a standard workout:

- (1) Leg extensions
- (2) Leg curl
- (3) Leg press (inverted leg presses not recommended for shipboard use)
- (4) Chest fly
- (5) Chest press regular
- (6) Chest press incline
- (7) Lateral pullover
- (8) Low row
- (9) Lateral pull-down
- (10) Shoulder lateral raise
- (11) Shoulder press
- (12) Triceps extension or press
- (13) Biceps curl
- (14) Abdominal
- (15) Low back

2.6.4 **LMRC.** LMRCs shall meet the following requirements:

- a. On ships with less than 100 accommodations, area shall be provided to stow books and magazines, such as a bookshelf or locker, in the wardroom lounge, CPO lounge, and crew lounge. Combined book stowage facilities shall provide not less than 1 linear foot of shelving per five accommodations.
- b. Ships with more than 100 accommodations shall have one or more dedicated spaces designated as the LMRC that are readily accessible to all crew members. LMRC space shall be sized as specified in Part I, [Table 2-7](#).

Table 2-7. LMRC Minimum Space Size Requirements ^{1/}.

Total accommodations (E-6 and below)	Minimum total LMRC size (ft ²)
101 – 400	280
401 – 1,000	340
1,001 – 4,000	600
Over 4,000	1,200

NOTE:
^{1/} The area allocation provided by this table shall accommodate furniture and stowage space associated with equipment identified in Part I, [Table 2-8](#).

c. The LMRC (or stowage and user space for smaller vessels) shall contain at least the equipment and stowage space specified in Part I, [Table 2-8](#). Each Personal Computer (PC) workstation shall include the following: a PC, electrical and network outlets, computer furniture with lockable CPU stowage, an area for the user to place paperwork, and ample space for a monitor, speakers, keyboard, and mouse. A file server shall be provided to serve the PCs in the LMRC. For LMRCs with less than four PCs, one of the PCs may be configured to also function as the file server. Computer furniture shall be equipped with electrical outlets. Audio/video equipment and product stowage shall be lockable and shall accommodate equipment such as CD players, DVD players, MP3 players, TV/DVD players (if not permanently mounted and secured), and items such as CD-ROMs and DVDs. An administrative area near the entrance to the LMRC equipped with a desk and work area shall be provided. In ships with more than 400 accommodations, the administrative area shall also include stowage for supplies, phone service, and wiring for a personal computer. In ships with more than 400 accommodations, shelving, study tables and chairs, lounge furniture, and periodical holders shall be provided.

Table 2-8. LMRC Equipment Quantities.

Workstations for PCs (laptops or desktops)	Printers/Scanners
Total accommodations (E-6 and below) × 60% × 2 hrs usage per person/hrs PCs available per week = # of workstations	One per 600 accommodations (E-6 and below)
Hrs PCs available per week:	
40 hrs for ships with up to 190 accommodations	
60 hrs for ships with 191 – 1,000 accommodations	
80 hrs for ships with over 1,000 accommodations	

NOTE:
 1. Area allocation for furniture and stowage space shall be provided based on equipment quantities above.

2.6.5 **Training.** Training facilities shall be consistent with the training plan for the ship’s force and embarked troops to fulfill qualification training and to promote personal development. Training facilities shall provide the capability, including furniture and equipment, for onboard instruction as appropriate to the training plan.

2.6.6 **Religious Ministry.** Religious ministry space shall meet the following requirements:

- a. All ships shall have sufficient space to conduct religious services.
- b. Ships with 1,000 or fewer accommodations may use such space as a messdeck or a lounge to conduct religious services. Lockable stowage for related religious items shall be provided.
- c. Ships with more than 1,000 accommodations shall have a separate space configured as a chapel with minimum seating capacity of 30 persons. All aircraft carrier chapels shall have a minimum seating capacity of 45 persons. Space configured as a chapel may be used for other activities compatible with its primary purpose.

d. Where practicable, a low capacity commercial off-the-shelf washer and dryer and a small lavatory with a high-rise spigot for the cleaning and maintenance of altar gear shall be located within a storeroom adjacent to or in the vicinity of any space configured as a chapel. Additionally, a small refrigerator with lock for opened sacramental wine and juice bottles and other perishable storage related to religious services shall be provided.

e. A chaplain storeroom shall be provided within the vicinity of or adjacent to the chapel with its access via the chapel. The chaplain storeroom shall have space sufficient to stow all gear required for the command religious program, including lockable space appropriate for the stowage of Eucharistic elements. Lockable ecclesiastical stowage shall be provided for books and pamphlets, as well as for Altar Ware, for linens and paraments (flat drawers) for vestments and robes (hanging), and for cleaning gear. A small refrigerator with lock for opened sacramental wine and juice bottles and other perishable storage related to religious services shall be provided. A safe with a drop-slot for Religious Offering Funds shall be provided, with a locking (secure) drawer for Navy Relief workers separate from the safe. Double lock protection shall be provided for sacramental wine stowage. If VCR/TV/DVD player equipment is not permanently mounted and secured, lockable stowage shall be provided.

f. A religious literature locker shall be provided in the passage outside the space used for worship and outside the chaplain's office. A bulletin board shall be provided in the passage outside the chapel or other space used for worship.

2.6.7 Audio Visual Television/Audio Systems.

a. A Shipboard Broadcast System (SBS) shall be provided that supports the mission of the Armed Forces Radio and Television Service (AFRTS) and Navy Motion Picture Service (NMPS). This system shall be capable of broadcasting internally and externally produced information, training, and entertainment video throughout the ship via the Digital Media Transport System (Circuit 30TV). The system shall provide entertainment and training capabilities via Blu-Ray/DVD players and video server capabilities. Command Information shall be provided using a digital signage capability. On LHD/LHA and CVN Class ships, a production component of SBS shall also be included that allows for live and recorded production capabilities.

b. A Satellite Television System (Circuit 29TV) shall be provided on all surface ships to allow reception of military (AFRTS/Armed Forces Network [AFN]) television services while the ship is underway via permanently mounted antennas. The system shall also allow reception of commercial (DirecTV) televisions services while the ship is in port via the same permanently mounted antennas. Circuit 29TV shall be capable of providing up to 10 channels of military programming and 96 channels of commercial programming.

c. Circuit 30TV shall be provided to allow distribution of video content created by SBS and Circuit 29TV throughout the ship. Televisions and associated set-top boxes will be provided, as a minimum, in cabins, staterooms, lounges, messrooms, and recreation spaces/areas. Wireless Access Points (WAPs) shall be provided that allow access to video content from SBS and Circuit 29TV on the crew's personal devices. WAPs will be provided in crew berthing areas, lounges, and recreation spaces/areas. The Circuit 30TV system shall be capable of transporting up to 500 channels of video content simultaneously. This includes, but is not limited to, 9AFRTS channels, 2 NMPS channels, 4 crew programmed channels, 5 command information channels, 96 commercial satellite channels, and 100 pier side channels and 100 surveillance camera feeds (on ships with a Circuit 28TV Unclassified Surveillance System).

2.7 SERVICE SPACES.

2.7.1 Barber Shop. Ships shall be provided with barbering facilities to accommodate requirements for male and female personnel in order to maintain Navy grooming standards. Barber shops shall be in accordance with the following:

- a. Barber facilities or services shall not be located within food service or berthing areas.
- b. Surface ships with 100 or fewer accommodations shall have portable barber services at a location with access to a hot and cold water faucet and a covered trash receptacle, such as a self-service laundry space. A designated locker shall be provided for stowage of barber items.
- c. Ships with more than 100 accommodations shall be provided with a dedicated barber shop and outfitted with barber chairs, one chair per 300 accommodations or fraction thereof, up to a maximum of 10 chairs. The barber shop shall be provided with a lavatory with hot and cold water and covered metal trash receptacle.
- d. Where two or more chairs are required for troops, a separate troop barber shop shall be provided. Where accommodation is over 1,000, a separate officer and enlisted barber facility shall be provided, segregated by a partition.
- e. Submarine tenders shall be provided two additional barber chairs beyond that number required by ship's company accommodations, in order to provide barber service to ship's company of tended submarines.

2.7.2 Post Office. Post Offices shall be either based on close-in littoral mission type platforms or blue water, self-sustaining mission type platforms in accordance with the following:

- a. Surface ships with close-in missions, such as LCS and MCM platforms, do not have Post Office or postal finance services. Incoming and outgoing mail shall be processed in the ship's supply department office.
- b. Surface ships with extremely constricted/limited space, such as DDG 1000 or Fast Frigate (FF) platforms, shall be provided with Post Office facilities and stowage space within the ship's store.
- c. Surface ships with blue water, self-sustaining missions, such as all amphibious (LCCs, LHAs, etc.), aircraft carrier (CVNs), surface combatant (CGs, DDGs), and auxiliary (ASs, etc.) ships shall be provided a separate Post Office or mailroom in a secure space to safeguard U.S. Postal Service postal effects and to store mail.
- d. Aircraft carriers and other surface ships, whose normal duties require accommodation of mail and parcel post for further transfer to other Fleet units, shall be provided with additional secure stowage for this purpose. Aircraft carriers and amphibious assault ships (LHDs and LHAs only) shall be provided a designated space, preferably within the hangar bay, capable of processing, sorting, and delivery of incoming mail.

2.7.3 Ship Store. The ship store shall be in accordance with the following requirements:

- a. All surface ships shall have a ship store or other sales outlet for items of personal necessity and hygiene, appropriate to the size of the ship.
- b. Ships with fewer than 300 accommodations shall provide, as a minimum, over-the-counter window service.
- c. In ships with 300 or more accommodations, walk-in facilities shall be provided, in order to control individual space size for security reasons.
- d. Exterior display windows and doors to ship stores shall be protected against break-in by security grills or security alarm systems and padlocks. Ship's store doors shall meet Group III security requirements of NAVSUP P-487.
- e. Where possible, the ship's store storerooms shall be located immediately adjacent to the ship's store served. Ship's store storerooms located separate from the ship's store shall be in close proximity to or in the same subdivision as the store or readily accessible to automated material handling equipment. Storeroom re-supply route passageways shall be clear of obstructions and shall be not less than 48 inches in width to accommodate movement of automated material handling equipment.

2.7.4 Vending Machines. Appropriately sized areas, separate from messrooms, shall be provided to accommodate vending machine installations. Vending machines shall be in accordance with the following requirements:

- a. Standard Vending Machines.
 - (1) Space, weight, and support system reservations shall be allocated for two vending machines (one beverage and one snack machine) per every 200 accommodations or fraction thereof. Reservations shall be provided to the Navy for review.
 - (2) Vending machine areas shall be centrally located, clear of the messdecks, and shall be provided with security grills or equivalent protection. Where possible, the vending storerooms shall be located in close proximity to the vending machine areas. When vending machines are installed in passages, they shall be in alcoves. The deck under vending machines shall be stiffened as required to provide rigid support free of excessive deflection. Where possible, sufficient trash receptacles shall be provided in the vicinity of the vending machines for segregating the different types of trash, such as aluminum, plastics, paper, etc.
 - (3) Vending machines shall be prevented from swaying by bolting to foundations and braces attached from the top of machines to the bulkhead and/or overhead. The vending machines shall be on legs 6 inches off the deck and 4 inches from bulkheads, or on sealed foundations similar to food service equipment requirement. Vending machine doors shall be provided with a latch back device to prevent sway while loading.
 - (4) Services to meet vending machine requirements shall include electrical power supply and a deck drain in the vicinity of each vending machine location.
- b. Canned Drink Vending in a Box (VIB).

(1) Canned drink VIB dispensing machine may be provided on ships with 1,000 or more accommodations. Provide canned drink VIBs on the basis of one per 750 accommodations (replaces the 1 beverage vending machine per 200 accommodations cited above in Part I, 2.7.4.a(1)). A combination of VIB and beverage vending machines may be provided in order to meet the minimum requirements for number of accommodations served.

(2) Provide adequate compartment size to accommodate the VIB system. VIBs shall be centrally located such as near ship's store areas, messdecks, and workspaces. Compartment(s) designated for VIB installation shall be provided with 84 inches overhead clearance. The deck under the VIB machines shall be stiffened as required to provide rigid support free of excessive deflection. Where possible, sufficient trash receptacles shall be provided in the vicinity of the VIB(s).

(3) Services to meet VIB requirements shall include, but not be limited to: chilled water for compressors, electrical power (440 VAC and 110 VAC), and deck drains. HVAC capability shall be provided in the VIB space to remove heat generated by the VIB compressor. S6163-EG-FSE-010 provides installation information for the VIB.

2.7.5 Laundry.

2.7.5.1 Ship's Institutional Full Service Laundry. Ship's institutional full service laundry shall be in accordance with the following requirements:

a. General. A manned institutional laundry facility shall be provided on ships with more than 100 accommodations for antiseptically processing (wash, dry, and finish) uniforms, work clothing, and organizational gear. The institutional laundry shall have provisions for receiving soiled laundry, issuing cleaned laundry, stowing soiled and cleaned bags of laundry (up to 60 pounds capacity each) in separate locations within the laundry, stowing finished garments on hangers, and stowing bundled laundry on shelves. The institutional laundry shall be located in proximity to high concentrations of crew living spaces as practical.

b. Sanitation Requirements. The minimum wash water temperature and hot air drying temperature shall be in accordance with NAVMED P-5010, Chapter 2, for hygienically safe laundry.

c. Capacity Requirements. The institutional laundry will operate on a 96-hour work week (16 hours/day, 6 days/week) and shall be provided with equipment, outfittings, furnishings, and all necessary support services (electrical, potable hot and cold water, LP air, ventilation, steam, drains) capable of processing 24 pounds per accommodation per week based on the following minimum requirements:

(1) One change of work clothing, underwear, and socks per accommodation per day and one towel per accommodation per day.

(2) One change of officer and CPO messroom linen per table per day.

(3) Provide laundry services on a daily basis for the following:

(a) Medical and dental gowns, smocks, towels, etc.

(b) Cook smocks, hats, and aprons.

(c) Barber smocks.

(4) Berthing linen on a weekly basis, and woolen blankets on a quarterly basis.

(5) Flight deck items capable of being laundered and contaminated medical items as required.

(6) Finish press two uniform shirts and trousers per officer and CPO/SNCO accommodation per week.

Tenders shall have institutional laundry capacities capable of supplementing facilities of two tended ships in addition to the requirements of their own ship's company.

(7) Washer-extractors and tumbler-dryers shall produce not less than one rated load per hour.

d. Equipment Requirements. The contractor shall select and procure only Navy approved laundry equipment in accordance with U.S. Navy Laundry Equipment Catalog S6152-B1-CAT-010 (see <http://usnhabeqptcatalog.gdit.com/>). Laundry equipment selected from other than the Shipboard Laundry Equipment Catalog shall be submitted to NAVSEA and the Habitability LCM for approval prior to procurement and installation.

Each category of equipment shall be the product of a single manufacturer. The laundry facilities shall include washer-extractors, tumbler dryers, and laundry presses/finishing equipment of sufficient mix, quantities, and capacities to meet the laundry capacity requirements. The equipment capacities shall be suitable for processing individual bulk lots of laundry up to 60 pounds each.

e. Installation Requirements.

- (1) All shipboard laundries shall be installed in accordance with the requirements of S9086-V4-STM-010/655.
- (2) All laundry equipment shall be arranged for proper operation, efficient work flow, and adequate maintenance clearances. Sufficient walkway clearances shall be provided for laundry baskets.
- (3) The equipment shall be mounted to hull foundations with hold down bolts, and torqued in accordance with manufacturer's specifications, to provide a metal-to-metal fit between the base of the machine and the hull foundation.
- (4) Electrical power, potable hot and cold water, LP air, ventilation, steam, and drain services shall be provided to the laundry equipment in accordance with the manufacturer's specifications.
- (5) Washer-extractors and service sinks shall be grouped together within a coaming containing deck drains of sufficient capacity to contain overflow and spills. The coaming shall be installed as close as practical to the front of the machine to prevent a tripping hazard to the operators.
- (6) Each washer-extractor drain shall be individually connected to the hard piping of the main drain system with a fitted flexible hose connection from the machine drain outlet.
- (7) The deck in way of the washer-extractors shall be reinforced as necessary to ensure that vibration during the extract cycle does not exceed the maximum allowable amplitude for Type I Vibration in accordance with MIL-STD-167-1.
- (8) Machines having drums rotating on a horizontal axis shall be installed with the axis fore and aft where practical.
- (9) Washer-extractors, washers, and tumbler dryers shall be fitted with flexible hose connections in accordance with S9086-V4-STM-010/655.
- (10) Tumbler dryers shall be provided dedicated exhaust ventilation with discharge directly to the weather. Individual secondary lint filters installed in a horizontal orientation, or a common lint arrestor, approximately 40 mesh/420 micron, shall be provided in the ventilation exhaust duct and shall be easily removable for safe and effective daily cleaning. A lint arrestor shall be fitted close to each dryer.
- (11) Laundry presses shall be installed with an exhaust ventilation hood rated at 500 cubic feet per minute (CFM). The hood shall be connected to the ship's exhaust ventilation duct with a flexible corrugated hose. Press hoods shall be provided with cleaning/maintenance access fitted with quick-access covers to allow for periodic cleaning and lubrication of mechanisms within the hoods.
- (12) Steam inlet connections to laundry equipment shall come off of the top of the steam header and be provided with a valved bypass line with integral steam trap and strainer to the condensate return header.
- (13) A cold potable water line shall be provided in the vicinity of the laundry presses with an overhead connection at each press station for attachment of a water misting gun/nozzle, located so the hanging spray hose does not interfere with operator movement at the press station.
- (14) Jack rods shall be provided in the laundry and issuing area for the stowage of finished garments on hangers. Jack rods shall permit movement of product on hangers along the length of the rod.
- (15) A built-in locker with shelves shall be provided for stowage of ready service laundry supplies.
- (16) Work tables, countertops, and sorting bins shall be CRES in accordance with ASTM A240/A240M, Type 304, Finish 4. Frames shall be aluminum in accordance with ASTM B209, Alloy 5052.

f. Testing Requirements. After the shipboard installation is complete, all laundry equipment shall be operated under full load conditions for a period of not less than 4 hours to determine that all equipment functions in accordance with the manufacturer's specifications.

2.7.5.2 Self-Service Laundries. Self-service laundries shall be in accordance with the following requirements:

a. Ships with Institutional Full Service Laundry Facility. Ships with more than 100 accommodations shall be provided with self-service laundry facility(s). These facilities shall be located in a dedicated space, in close proximity to high concentrations of crew living spaces, as practical, and in a separate location from the ship's institutional laundry. Where practical, a separate facility shall be provided for crew, CPO, and officers. For 100 to 499 accommodations, 1 washer and 1 dryer shall be provided per each 30 accommodations; for 500 to 1,499 accommodations, 1 washer and 1 dryer shall be provided for each 50 accommodations; and for 1,500 accommodations and above, 1 washer and 1 dryer shall be provided for every 100 accommodations. The ratio of dryer capacity to washer capacity shall be a minimum of 1 to 1. Each washer and dryer capacity shall be 16 to 20 pounds. One hand iron and 1 ironing board shall be provided per 50 accommodations, or major fraction thereof, in each self-service laundry space. Alternate locations for hand irons and ironing boards may be in lounge spaces or berthing spaces with the approval of NAVSEA. The ironing boards shall be covered with a fireproof cloth cover. A means shall be provided for stowing the irons and ironing boards.

Two hose bib faucets shall be provided, one for hot and one for cold potable water, to each washing machine. These faucets shall be located above the coaming area. Drain shall be individually connected to the hard piping of the main drain system with a fitted flexible hose connection from the machine drain outlet. Washer machines shall be grouped together within a coaming with deck drains of sufficient capacity to contain overflow and spills. The coaming shall be installed as close as practical to the front of the machine to prevent a tripping hazard.

b. Ships with No Institutional Full Service Laundry Facility.

(1) Ships without institutional laundry facilities shall be outfitted with self-service laundry facilities with at least 1 washer and 1 dryer per 20 accommodations. One hand iron and 1 ironing board shall be provided per 50 accommodations, or fraction thereof, in each self-service laundry space. Alternate locations for hand irons and ironing boards may be in lounge spaces or berthing spaces with the approval of NAVSEA.

(2) The ironing boards shall be covered with a fireproof cloth cover. A means shall be provided for stowing the irons and ironing boards. The self-service laundry shall be located in close proximity to high concentrations of crew living spaces. A separate facility shall be provided for crew, CPO, and officers. Each washer and dryer capacity shall be 16 to 20 pounds.

(3) Two hose bib faucets shall be provided, one for hot and one for cold potable water, to each washing machine. These faucets shall be located above the coaming area. Drain shall be individually connected to the hard piping of the main drain system with a fitted flexible hose connection from the machine drain outlet. Washer machines shall be grouped together within a coaming with deck drains of sufficient capacity to contain overflow and spills. The coaming shall be installed as close as practical to the front of the machine to prevent a tripping hazard.

c. Tumbler Dryers. Tumbler dryers shall be provided dedicated exhaust ventilation with discharge directly to the weather. Individual secondary lint filters installed in a horizontal orientation, or a common lint arrestor, approximately 40 mesh/420 micron, shall be provided in the ventilation exhaust duct and shall be easily removable for safe and effective daily cleaning. A lint arrestor shall be fitted close to each dryer.

CHAPTER 3 MEDICAL AND DENTAL SPACES

3.1 GENERAL.

The purpose of this section is to provide criteria for the design of medical and dental spaces and the integration of the health service support function into the total ship general arrangement design. Hospital ships are not addressed by this manual.

3.2 SHIP TYPES.

Casualty Receiving and Treatment Ships (CRTS) receive personnel casualties by surface or aircraft, provide stabilizing medical care, and evacuate the casualties for further medical care. CRTS are generally provided on FORCE PROJECTION classed vessels (specifically LHA, LHD, and LPD vessels). CRTS capabilities may be differentiated by the quantities/types of casualties capable of being received, the number and type of augmenting medical personnel, quantities of medical supplies carried, and the respective sizes of their medical spaces. The Navy shall identify vessels requiring CRTS in the Request for Class.

For other ships, the medical and dental capabilities required of a particular ship design are established by the Navy. Small ships require at least one Battle Dressing Station (BDS) which may be combined with a medical treatment room. Larger ships with assigned medical personnel and fewer than 500 accommodations require at least one BDS in addition to a medical treatment room. The BDS quantity shall be in accordance with Part I, [Table 3-1](#).

3.3 GENERAL REQUIREMENTS FOR SPACES.

3.3.1 Location. Separate medical accommodations shall be provided, suitably separated from other spaces, to be used for the care of the sick or injured and for no other purpose. The accommodations shall be designed to always be ready to receive sick or injured patients. The spaces are not to be designed as a storage area. The medical accommodations shall be suitably located to allow for safe and efficient access for sick or injured personnel, stretcher transportation from accommodations or work areas, and to provide comfortable service and proper attention in all weather conditions. Non-slip type deck coverings shall be supplied in accordance with NAVSEA Standard Item 009-26 in medical and dental spaces since occasional water, oil, blood/blood products, or other liquids on the floors is expected.

3.3.2 Water System. A separate water system supplying potable water to the medical accommodations shall be installed. BDS fresh water storage tanks shall be installed high in the overhead. On ships designated as CRTS, tanks shall be sized to contain 200 gallons. On other ships, tanks shall contain not less than 50 gallons. Operating instructions to fill, drain, isolate, and operate the emergency water supply shall be posted near the system. Inspection ports/manhole cover(s) shall have intact gasket, as required, and hardware shall not be painted to facilitate easy removal for periodic inspection/cleaning. Vents and/or overflow lines provided on potable water tanks shall be located to reduce the possibility of contamination. The openings shall be screened with 18-mesh or finer non-corrosive metal wire to prevent pest and vermin access. A sight glass with a guard or drycock shall be installed.

3.3.3 Dimensional Aspects. General dimensions for medical and dental spaces shall be in accordance with the general requirements provided in Part I, 1.8. Headroom in the medical accommodations shall be at least 78 inches. Outside corners of medical accommodations bulkheads, doors, etc., corners that crews members may strike, shall be rounded to a radius of 0.5 inch or more.

3.3.4 Medical and Dental Space Arrangements. For new ship designs or existing ship modifications, the Afloat Medical Program Technical Warrant Holder (TWH) shall work with the TYCOM Force Surgeons to ensure all medical and dental space arrangements are appropriate to support medical and dental equipment identified by the Naval Medical Logistics Command.

3.4 DRAWINGS AND DATA TO BE SUBMITTED.

In the Preliminary and Contract Design Phases, the design agent shall provide compartment arrangement drawings of the specific medical and dental spaces to be included on the vessel, and arrangement of installed furniture and equipment therein as understood from review of Part I, [Table 3-1](#) and Part I, [Table 3-2](#), for review and approval by the Naval Afloat Medical Program TWH. In addition, for each medical space identified, a list of proposed equipage shall be submitted for review and approval. These equipage lists shall be in accordance with the requirements identified by the Naval Afloat Medical Program TWH in the specifications for the vessel. For detail design, drawings and data shall be submitted and an additional plan view of the vessel shall identify locations of First Aid Boxes, Portable Medical Lockers/Mass Casualty Boxes, Stokes and Decontamination Litters, Spineboards with Reeve Sleeves II, Gun Bags, and Oxygen Cylinders. Where the identified specifications for equipment have been overtaken by new equivalent designs, those new equivalent specifications shall be submitted for consideration and acceptance by the Naval Afloat Medical Program TWH.

3.5 TESTING.

The builder/contractor shall demonstrate to the Supervisor or designated Navy representative that hotel services necessary for the required medical equipment are satisfactory and that the equipment is securely installed in the space. Maintenance access shall be provided for all equipment in accordance with manufacturer's instructions. After installation, the operation of the medical equipment shall be demonstrated by the equipment vendor or the shipbuilder to the satisfaction of the Navy identified Biomedical Equipment Technician (BMET), Naval Afloat Medical Program TWH, SUPSHIP medical representative, or other representatives designated by the Navy or Supervisor, to demonstrate functionality of the equipment.

Upon installation of X-ray equipment, the installer shall request a qualified Medical Representative from the Navy to perform the Acceptance Inspection of diagnostic X-ray equipment. This inspection shall be accomplished within 30 days of the installation and prior to initial clinical use. Inspection results shall be submitted to the Supervisor or designated Navy representative.

3.6 REQUIRED MEDICAL SPACES.

On ships with a significant requirement for medical and support capabilities, the entire system of medical spaces should be considered as an integrated unit. The space configurations and their placement within the general arrangement of the ship should provide for the maximum functional relationship of these spaces. Storage shall be provided for medical supplies. On amphibious platforms and carriers, office space shall be allocated for the Department Head (typically the Senior Medical Officer), and Senior Enlisted Leader/Departmental Leading Chief Petty Officer.

For the U.S. Navy, the Naval Afloat Medical Program TWH, TYCOM Force Surgeons, and the Bureau of Medicine and Surgery (BUMED) shall approve the space configuration, types and quantities of equipment, and equipment arrangement. U.S. Navy equipment shall be approved by the TYCOM Force Surgeons and Naval Medical Logistics Command (NMLC). These guidelines may be superseded by requirements set forth in the Naval Afloat Medical Program TWH Fleet instructions and other procurement documentation.

Part I, [Table 3-1](#) identifies the numbers and types of spaces to be included on naval vessels. The criteria for spaces can be called out based upon total accommodations for the vessel, designation as a CRTS, class designation, or other Fleet requirements. Medical spaces are to be located towards the centerline of the vessels and centered fore and aft as much as possible to reduce the effect of ship movements on medical care giving.

Table 3-1. Medical Space Requirements for Naval Vessels.

Space	Type of ships on which required and number required	Notes
Aviation examining room	FORCE PROJECTION	Space shall be capable of conversion to an operating room.
Battle dressing station (BDS)	<p>Only required on ships with medical personnel assigned. Mine Warfare and Fleet Support Craft – 1 each (primary medical spaces on these small ships shall also serve as their BDS)</p> <p>Larger ships with less than 500 accommodations – 1 each in addition to primary medical spaces accommodations</p> <p>500 to 2,000 accommodations – 2 in addition to primary medical spaces</p> <p>2,000 or more accommodations – 1 additional per each 1,000 accommodations</p>	<p>A BDS shall be provided in the immediate vicinity of the casualty reception area and well deck on CRTS. On FORCE PROJECTION ships, a BDS shall be provided within the island structure with easy access to the flight decks. The location cannot impair the primary use of the space as a BDS, restrict ingress/egress of injured crew members, compromise the maintenance and security of medical supplies and equipment, or restrict medical department personnel from unlimited access to the spaces. All doors leading into and out of BDSs shall be a minimum of 36 inches wide.</p>
Bio-medical equipment repair workshop	FORCE PROJECTION	
Blood bank	FORCE PROJECTION, CRTS	
Blood bank, frozen	FORCE PROJECTION, CRTS	Only included in large CRTS as determined by the Navy
Cast room	FORCE PROJECTION, Naval Support, CRTS	
Casualty collecting (Triage)	CRTS, FORCE PROJECTION	<p>Dedicated space for collection and triage of casualties. The space shall be located within or adjacent to medical spaces on the clean side of Chemical, Biological, and Radiological (CBR) decontamination boundaries. The space shall have an installed water hose and drains for cleaning. The space shall have capacity for five litters per operating room.</p>

Table 3-1. Medical Space Requirements for Naval Vessels – Continued.

Space	Type of ships on which required and number required	Notes
Contaminated triage area	Ships with Collective Protection System (CPS) Casualty Decontamination Station (CDS)	A separate space for the CBR Contaminated Triage Area shall be allotted outside the entrance to each CPS CDS. This is a temporary, 10 feet by 10 feet area at the entrance to the CDS, preferably with an overhang or in a hangar bay. 804-6983509 delineates this area in relation to the CDS and lists the labels describing the actions to be taken in this area. S9086-QH-STM-010/470 contains a notional layout and describes the functions.
Consultation room	Each medical officer – 1 each Each permanently assigned physician assistant – 1 each	
Diet pantry	FORCE PROJECTION	
Eye, ear, nose, and throat (EENT) treatment room	More than 1,300 accommodations (unless provided with an aviation examining room)	
Eye examining range room (eye lane)	1 each	Required if eye examinations cannot be conducted in the aviation examining room or EENT treatment room.
Gowning room	CRTS	
Laboratory, bacteriological and clinical	Where laboratory technicians assigned	
Medical apparatus room	FORCE PROJECTION	The medical apparatus room provides space to contain the body of the medical sterilizers specified in the medical sterilizing room.
Medical linen issue room	20 or more total medical beds and berths	Multiple medical linen issue rooms may be required to stow the large quantities of medical linen carried on FORCE PROJECTION ships.
Medical sterilizing room	FORCE PROJECTION, CRTS	If the medical sterilizing room is contiguous to the dental spaces, a separate dental sterilizing room is not required.
Medical treatment room	500 or less accommodations	
Medical utility room	10 or more ward beds/berths	Less than 10 ward beds and berths shall have the listed equipment provided in the ward WR, WC, and SH.

Table 3-1. Medical Space Requirements for Naval Vessels – Continued.

Space	Type of ships on which required and number required	Notes
Medical waste processing and holding room	LHD/LHA/LPD 17	
Medical X-ray exposure room	1 each for every 3 operating rooms, not less than 1 on CRTS	
Morgue	CRTS	Refrigerator size shall be based on 2% total medical beds, including casualty overflow berths.
Operating room	1 provided on each ship with 600 accommodations 1 additional operating room shall be provided on CRTS for each additional 600 accommodations	Surgical dressing rooms and aviation examining rooms shall be outfitted as equivalent operating rooms.
Pharmacy	FORCE PROJECTION	
Quiet room and isolation room	A quiet room bath shall be provided immediately adjacent to quiet rooms On ships with women assigned, quiet rooms may be used as female wards	
Scrub room	Ships with operating rooms May be included in the medical sterilizing room on ships with only 1 operating room 1 for every 3 operating rooms in CRTS	Multiple scrub stations may be provided within one scrub room if direct access to more than one operating room from scrub room. Scrub rooms shall be contiguous with operating rooms and in close proximity to medical apparatus room and medical sterilizing room. Doors leading into the operating rooms from the scrub rooms and scrub stations shall be fitted with door opening and closing devices that do not require hand operation.
Surgical dressing room	500 or more accommodations	Space shall be convertible to an operating room. On ships with women assigned, examining table shall be equipped for gynecological exams.
Ward, basic	Non-CRTS without a medical officer (nor augmentation requirement)	A ward WR, WC, and SH shall be provided immediately adjacent to the ward.
Ward, Intensive Care Unit (ICU)	FORCE PROJECTION	A ward WR, WC, and SH shall be provided immediately adjacent to the intensive care ward.
Ward, primary	FORCE PROJECTION	A ward WR, WC, and SH shall be provided immediately adjacent to the primary ward.
Waste processing	All vessels with medical facilities	A space to receive, process, and hold medical waste generated from the medical spaces.

3.7 OUTFITTING OF MEDICAL SPACES.

3.7.1 General Outfitting for Spaces.

a. All furniture and equipment in the medical facilities shall be in accordance with the furniture and equipment requirements identified by the Navy. The contractor may propose alternate specification or commercial off the shelf (COTS) equipment for consideration by the Navy. Fresh water drains and connections shall be provided for all equipment that requires the connections. Deck drains are not authorized in dental spaces where mercury or mercury compounds are handled or stored in accordance with the Mercury Control Program For Dental Treatment Spaces (BUMEDINST 6260.30).

b. The medical accommodations shall have communications to the navigation bridge. Radiators and other heating apparatus, which may cause a risk of fire, danger, or discomfort to the crewmembers, shall be shielded. Radiation shielding shall be provided for personnel protection in way of X-ray equipment. Oxygen, electrical, plumbing, ventilation systems, and other hotel services required by the Navy shall be designed and installed as required unless otherwise stated herein or by the Navy.

c. In spaces with overhead sheathing, the surgical light mounting brackets and the regular light fixtures shall be flush-mounted. The overhead relay operated lanterns located above operating tables, examination and treatment tables and chairs, dental operating chairs, and intensive care beds shall be wired and connected to toggle switches. Sheathing specified for medical and dental spaces shall be free of projections and dust collecting surfaces.

d. The sanitary facilities, quiet room, ICU, and ward berths shall have a call system for emergency use by patients. Call buttons shall be located 28 to 30 inches above the deck outside shower splash zone.

e. On ships with more than 250 accommodations, a hinged, folding, drop-down type bench, similar to 804-1634565 (modified to eliminate the stowage under) shall be provided in passages adjacent to the consultation rooms, medical treatment room, medical department office, medical records office, flight surgeon's office, surgical dressing room, pharmacy, medical laboratory, and dental treatment rooms to serve as a waiting area. The location of the waiting area shall be reviewed by Fleet Medical and Afloat Medical Program TWH.

f. Where bookracks are specified, Type A bookracks in accordance with 805-1749061 shall be installed only where they can be fitted directly over a desk or table. Otherwise, Type B bookracks shall be provided.

g. Self-contained refrigeration units providing stowage for biological and pharmaceutical supplies shall be able to maintain an internal temperature range of 36 to 46 °F (2 to 8 °C) in accordance with MIL-PRF-32497 and the CDC Vaccine Storage and Handling Toolkit. Set temperatures shall be in accordance with BUMEDINST 6230.15, COMNAVSURFPAC/COMNAVSURFLANT Instruction 6000.1, and the CDC Vaccine Storage and Handling Toolkit (see <http://www.cdc.gov/vaccines/hcp/admin/storage/toolkit/>). Where provided, mortuary refrigeration unit temperature ranges shall be set in accordance with the commercial vendor's technical specifications. These refrigeration units shall be provided with local and remote (manned spaces) alarm systems.

h. Securing devices shall be provided for portable and mobile equipment. Securing devices on the deck shall be flush-mounted. Mobile equipment shall be provided with quick-release mechanisms at their stowed locations. Additionally, securing devices shall be provided on the deck around operating and treatment tables to prevent equipment from moving from their required position during use. These devices shall not present trip hazards nor leave uncovered depressions that permit accumulation of debris or liquids that would enhance microbial growth.

3.7.2 **Medical Beds and Berths.** Beds and berths shall be provided in the following types and percentages or minimum quantities (see Part I, [Table 3-2](#)).

Table 3-2. Beds and Berths.

Type of beds/berths	Type of vessel	Minimum number of hospital berths
Medical beds and berths	CRTS and tenders	2% total accommodations
	Other ships	1% total accommodations
	Ships with attached Medical Department Representative	At least 2
Intensive care and postoperative recovery beds ^{1/}	CRTS	3 adjustable hospital beds with gatch fittings for each medical operating room
	Other ships	2 of these beds for each operating room
Medical ward berths ^{2/}	Ships with medical personnel assigned	At least 2
	CRTS	65% total medical beds
	Other ships	80% total medical beds
Casualty overflow convertible berths ^{3/}	CRTS	90 berths per operating room
<p>NOTES:</p> <p>^{1/} These beds shall be located within a postoperative recovery and intensive care ward or arranged in close proximity to each other in the primary medical ward.</p> <p>^{2/} Ward berths shall be in accordance with 805-1641006.</p> <p>^{3/} Casualty overflow berths shall be the two berths nearest the deck in a single tier berthing module.</p>		

3.7.3 **Exam and Operating Tables.**

a. Exam Tables. A minimum clearance envelope of 18 inches shall be provided around exam tables, and privacy curtains shall also be provided.

b. Operating Tables. A minimum clearance envelope of 60 inches shall be provided around operating tables to ensure medical providers and portable equipment have full access around the patient.

3.8 **REQUIRED DENTAL SPACES.**

Part I, [Table 3-3](#) identifies the numbers and types of dental spaces to be included on naval vessels. The criteria for spaces can be called out based upon total accommodations for the vessel, designation as a CRTS, Class designation, or other factors. Ships with 700 or more accommodations require dental departments. One general dental operating room shall be provided for every 700 accommodations. Storage shall be provided for dental supplies.

On amphibious platforms and carriers, office space shall be allocated for the Dental Officer.

The dental space requirements to support one dental officer shall not be less than one general dental operating room, one oral hygiene/X-ray dental operating room, a dental sterilization room, and a dental apparatus room.

Table 3-3. Dental Space Requirements for Naval Vessels.

Space	Type of ships on which required and number required	Notes
Dental apparatus room	Required on ships with one or more dental general operating rooms	
Dental ceramic laboratory	Required on FORCE PROJECTION classed vessels	
Dental operating room (General)	1 required for each dental officer assigned	
Dental operating room (Oral hygiene/X-ray)	Required on ships with a single dental general operating room	
Dental operating room (Oral surgery)	Required on ships with more than three dental operating rooms and CRTS	
Dental operating room (Prosthetics)	Required on ships having a dental prosthetics laboratory and shall be located adjacent to the prosthetics laboratory	
Dental prosthetics laboratory	Required on ships with more than three dental operating rooms, excluding LHAs/LHDs	
Dental sterilizing room	Required on ships with dental capability. Ships with three or less dental general operating rooms require no less than 90 square feet; ships with four or more dental operating rooms require no less than 120 square feet	If the medical sterilizing room is contiguous to the dental spaces, a separate dental sterilizing is not required.
Dental treatment support laboratory	Required on ships without a dental prosthetic laboratory (90 square feet required for this space)	
Dental X-ray exposure and digital radiography room	Required on ships with three or more dental general operating rooms	
Waste processing	All vessels with dental facilities	A space to receive, process, and hold medical waste generated from the dental spaces.

3.9 OUTFITTING OF DENTAL SPACES.

All furniture and equipment in the dental spaces shall be in accordance with the furniture and equipment requirements identified by the Navy. The contractor may propose alternate specification or COTS equipment for consideration by the Navy.

Fresh water drains and connections shall be provided for all equipment that requires the connections. Deck drains are not authorized in dental spaces where mercury or mercury compounds are handled or stored in accordance with the Mercury Control Program For Dental Treatment Spaces (BUMEDINST 6260.30).

Dental operating rooms shall be provided with a central evacuation system that is vented to the exterior of the ship, as required. Low pressure air, oxygen, electrical, plumbing, and ventilation systems, and other hotel services required by the Navy, shall be designed and installed as required in the ship specification unless otherwise stated herein or by the Navy. Instructions for aligning and operating dental air systems (primary/back-up) shall be provided. Dental electrical equipment shall be protected against line power surges.

3.10 DISTRIBUTED MEDICAL EQUIPMENT REQUIREMENTS.

3.10.1 First Aid Boxes (FAB). First aid boxes in accordance with S3702-921917 shall be provided as a means for dispersing emergency supplies throughout the ship for use by the crew. Each FAB shall be marked with a red cross and "FOR EMERGENCY USE ONLY" in 1-inch high red letters in accordance with COMNAVSURFPAC/COMNAVSURFLANT Instruction 6000.1 and shall be provided, at a minimum, in weather protected areas, in or near each of the following spaces:

- a. Air control spaces.
- b. Anchor handling spaces.
- c. Ship control spaces, including Pilot House, Flag Control, Combat Information Center (CIC), Damage Control Central (DCC), After Steering, and all Repair Lockers.
- d. Cargo holds and magazines.
- e. Manned communication spaces.
- f. Hangars and hangar deck bays.
- g. Manned engine and fire room spaces.
- h. Machine shops, general workshops, or other industrial work centers.
- i. Weapon control spaces.
- j. Laundry.
- k. Each galley (including bakery), scullery, and messroom.
- l. Near flammable material storerooms.
- m. Vicinity of OOD stations and mooring stations.
- n. Windlass machinery room.

A FAB can serve several locations if it is mounted within 100 feet of and on the same deck level as the required spaces. Additional areas for FABs may be designated by the Afloat Medical TWH. Other FABs may be mounted at the discretion of the Supervisor or Attending Surveyor after consulting with Afloat Medical TWH with special attention to areas where personnel are assigned major work stations, near flammable storerooms, and in major passageways.

3.10.2 Portable Medical Lockers (PMLs)/Mass Casualty Boxes (MCBs). Portable Medical Lockers (PMLs)/Mass Casualty Boxes (MCBs) shall be provided on each ship with a medical department representative. One PML/MCB shall be provided for each 200 accommodations. Not less than two lockers are required on any ship. One PML/MCB shall be located near, but not in, each repair party locker. Ships with a helicopter or aircraft capability shall have not less than one PML/MCB installed in or near each hangar in an easily accessible and weather protected area. After the above listed mandatory spaces have been accommodated, any remaining PML/MCBs shall be installed in the designated medical triage area. Appropriate brackets, shelves, and lashing shall be provided for each PML/MCB to prevent movement.

3.10.3 Stretchers/Litters. Stretchers/litters shall be in accordance with COMNAVSURFPAC/COMNAVSURFLANT Instruction 6000.1 and stowed with appropriate stowage brackets in weather protected areas.

- a. The number of Stokes litters shall be provided as follows:
 - (1) For the first 3,000 accommodations, there shall be 1.5 litters per 100 accommodations (minimum of 7), to include the following mandatory locations:
 - (a) Battle dressing station – one.
 - (b) Each messing space – one.
 - (c) Flight deck and helicopter deck; Stokes type – one, sea-air rescue type – one.
 - (d) Transfer at sea station – one Stokes type rigged in accordance with NTTP 4-01.4.
 - (2) For more than 3,000 accommodations, there shall be 1 Stokes type litter per 100 accommodations. Any quantity of litters in excess of the required locations shall be installed along passages used by damage control parties.
- b. One sea-air rescue litter with trail line assembly shall be stowed in the aviation workshop or vertical replenishment (VERTREP) locker.

c. Decontamination litters shall be provided on tenders and CRTS. Decontamination litters on CRTS shall be provided with two litter supports per litter. Stowage brackets shall be provided in casualty reception and triage areas. No more than 50 percent of total authorized decontamination litters shall be stowed in storeroom spaces. The total required decontamination litters shall be one for each authorized patient bed plus triage requirements.

d. Spine boards with Reeves sleeves II, or equal, shall be provided. One litter, with stowage brackets, shall be installed near the uppermost exit of each escape trunk with vertical ladders.

3.10.4 Gun Bags. Gun bags shall be in accordance with COMNAVSURFPAC/COMNAVSURFLANT Instruction 6000.1. These first aid kits are considered sufficient for 12 people. The number of stowage brackets and hooks for battle stations remote from a bulkhead mounted first aid box or where 12 or more persons are concentrated shall be as required by the Navy.

3.10.5 Cylinder, Oxygen, Size D. Two cylinders (in accordance with RR-C-901), with stowage brackets, shall be installed near the head of the operating and treatment tables in each battle dressing station, medical treatment room, surgical dressing room, aviation examining room, and Eye, Ear, Nose, and Throat (EENT) treatment room. One cylinder, with stowage bracket, shall be installed in the casualty receiving/triage area for each allotted litter location. Since these cylinders are transported with the litter patient to the medical treatment spaces, stowage brackets near the heads of the litter locations are not required. Cylinder stowage shall be in accordance with Grade B shock requirements of MIL-S-901 and COMNAVSURFPAC/COMNAVSURFLANT Instruction 6000.1.

3.10.6 Cylinder, Oxygen, Size H. When a piped-in oxygen system is not installed, the following shall apply: One cylinder (in accordance with RR-C-901) shall be installed in each battle dressing station, medical treatment room, surgical dressing room, aviation examining room, EENT treatment room, and operating room. One cylinder shall be installed at the head of each intensive care and recovery room bed, for every two ward beds or every four ward berths. One cylinder shall be installed for every two litter spaces in the casualty collection (triage) area. The cylinders shall be arranged around the spaces' peripheries. Cylinder stowage shall be in accordance with Grade B shock requirements of MIL-S-901 and COMNAVSURFPAC/COMNAVSURFLANT Instruction 6000.1.

CHAPTER 4 HABITABILITY STOREROOMS

4.1 GENERAL.

The size of stowage required to support ship's personnel shall be based on shipboard accommodations, endurance, outfitting, and calculation requirements. Types of stowage spaces supporting habitability include freeze, chill, and dry provision storerooms, provisions issue room, meat thaw room, ship store storeroom, canned drinks storeroom, general use consumables storeroom, clothing storeroom, and medical and dental storerooms. The stowage space area and volume requirements shall be based on the number of days of endurance for wartime in accordance with OPNAVINST 4442.1 or as specified in the Capabilities Development Document (CDD), and MIL-HDBK-2189/672-1 for calculating storeroom capacities. The requirements of OPNAVINST 4442.1 are the desired minimum levels of endurance; constraining factors influencing space requirements, and stockage objectives may be overriding. In such cases, the reduced stowage space requirement shall be as specified in the ship's CDD.

PART II, DESIGN PRACTICES

Part II is provided as a guide supporting Part I for shipboard habitability facilities.

CHAPTER 1 GENERAL DESIGN GUIDANCE

1.1 GOAL.

The goal and definition of habitability are described in OPNAVINST 9640.1.

“The Navy’s primary mission is to be prepared to conduct prompt and sustained combat operations at sea in support of U.S. national interests and the national military strategy. The navy is dependent upon shipboard personnel to accomplish this mission and therefore must provide them with living and working conditions which will result in levels of crew morale, safety, health and comfort, adequate to sustain maximum personnel effectiveness and to support optimum personnel retention. Habitability is that military characteristic of U.S. Navy ships which is directed toward satisfying personnel needs which are dependent upon the physical environment.”

Habitability design is, therefore, the design of the shipboard physical environment with respect to meeting personnel needs. Good habitability design, when integrated with all other ship systems design, satisfies these needs at minimum cost as normally measured in terms of allocated space and weight.

1.2 STANDARDS.

Habitability standards, representing minimum design requirements, were developed in the 1950s based on Fleet surveys and human engineering practices. They have been maintained by OPNAV with few changes. The standards differentiate between new construction and existing ships and note several important differences between ship types. The standards also define small ships as 150 to 300 feet, mid-size ships as 301 to 600 feet, and large ships as greater than 600 feet.

1.3 MANNING.

Shipboard manning is the largest driver of habitability space requirements. Personnel requirements are in turn driven by a ship’s required operational capabilities and projected operating environment. For new ship designs, accommodation design margin and SLA are included in the ship design development process. The design margin is needed to account for expected growth in manning requirements, as it is better defined and matures from the early stage of design development to detail design; and the SLA is needed for expected manning increases during its life cycle as new capabilities are added.

1.4 DESIGN AND DEVELOPMENT OF HABITABILITY FACILITIES.

An acceptable level of compliance based on the criteria of Part I and design practices of Part II will be assessed through the contractor’s submittal of the deliverables. These shall include those listed in Part II, [Table 1-1](#). A Habitability Design compliance report shall be submitted to NAVSEA for review and approval. This report shall summarize the successful completion of each of the deliverables specified in Part II, [Table 1-1](#), which will provide a means to show satisfactory completion of deliverables is documented and that an acceptable level of compliance has been achieved in accordance with the requirements of this manual.

1.4.1 Habitability Design Development Process. This section provides specific guidance for the preparation of habitability design products for each phase of the design development that will need to be accomplished in conjunction with general arrangements design development phases. The development of habitability facilities based on the criteria and practices herein is considered essential to achieve an acceptable product for the Navy.

The review process shall go through a number of design iterations to ensure acceptable progress with workable design solutions and ensure adequate area/volume are provided for habitability spaces during the course of general arrangements design development where other systems, such as ducting, piping, wireways, and ship structures, may encroach on area requirements for habitability spaces.

The habitability design improvements should incorporate lessons learned from trial cards, reports, Fleet input, construction methods, food handling, etc. Updates and adjustments should continually be made as the habitability design development matures to final design from feasibility to preliminary to detail design development.

1.4.2 Feasibility Study Phase.

a. The major tasks of the feasibility study include:

- (1) Define a set of technically feasible alternatives to support a set of Tentative Operational Requirements (TORs).
- (2) Provide design alternatives balancing capabilities, costs, and risks.
- (3) Identify major technical risks associated with each alternative.

b. Feasibility studies involve a series of trade-off evaluations on design parameters that may have a significant impact on crew performance, quality of life, safety, size, cost, and risk. The concept with the best outcome will be selected as the design configuration for development during the preliminary design phase.

Feasibility studies include parametric computer generated models to allow a number of different concepts to be evaluated and analyzed. The primary role of habitability during this time is the identification of habitability spaces and sizing requirements of these spaces. This information should be fed into general arrangements feasibility studies design development, also occurring at the same time.

1.4.3 Preliminary Design Phase.

a. The major tasks of preliminary design include:

- (1) Improve habitability system designs and reduce or eliminate major technical risks.
- (2) Refine habitability compartment sizing requirements.
- (3) Refine/develop compartment requirements, including area/volume, walkway clearances, outfitting, equipment maintenance clearance envelopes, etc.
- (4) Refine habitability requirements to support accommodations for ship's company, detachments, and surge.

(5) Refine alignment of habitability spaces for cost-effective installation, alignment of berthing and sanitary spaces from deck-to-deck to minimize piping runs, vents, etc. Provisions stores should line up with galley spaces to optimize strike-down/strike-up handling operations.

b. Deliverables for the preliminary design phase include:

- (1) Preliminary layouts of the habitability spaces, including food service spaces, laundry facilities, berthing spaces, sanitary spaces, etc.
- (2) Habitability preliminary design notebook.

1.4.4 Contract Design. During contract design, several contractual technical documents shall be developed consisting of:

- a. Ship specification sections detailing habitability requirements.
- b. Habitability contract drawings, when required.
- c. Contract data requirements lists (CDRLs) for all drawings and reports required by ship specifications.

In addition to habitability drawing development, updates are made to the reports and studies initiated in preliminary design (but which are not part of the contract package) to correspond to refinements and changes made during contract design. Specific reports and studies should be included in a habitability contract design notebook.

Table 1-1. Habitability Design Products by Design Stage.

Deliverable title	Applicability ^{1/}					
	Preliminary design products		Contract design products			Detail design (CDRL)
	S	A	C	G	A	A
Habitability study report	X	X				
Living space arrangement drawing ^{2/}	X	X		X	X	
Office study report	X	X				
Office space arrangement drawing	X	X		X	X	
Medical study report	X	X				
Medical and dental space arrangement drawing	X	X	X		X	
Freeze, chill, and dry provisions storeroom drawing	X	X		X	X	
Food service study report	X	X				
Food service space arrangement drawing ^{3/}	X	X	X		X	
Laundry facilities study report	X	X				
Laundry facilities arrangement drawing	X	X	X		X	
Personal services arrangement drawing ^{4/}	X	X		X	X	
Color coordination manual (DI-MISC-81123)						X
Compartment noise treatment plan	X	X				X
Compartment noise treatment report	X	X				X
Habitability furniture and equipment list ^{5/}						X
Medical and dental furniture and equipment list ^{5/}	X	X				X

NOTES:

^{1/} S – Study, C – Contractual, G – Guidance, A – Technical Warrant Approval.

^{2/} Includes: Berthing, Sanitary, Lounge, Recreation, Physical Fitness, Library Multimedia Resource Center, Religious Ministry, and Training spaces.

^{3/} Includes: Galley, Scullery, and Messing spaces.

^{4/} Includes: Barber Shop, Post Office, Ship Store, and Vending Area.

^{5/} The Government reserves the right to acquire and review furniture and equipment technical documentation and/or perform inspections of furniture and equipment where deemed necessary to assure such furniture and equipment conforms to prescribed requirements.

1.5 COMPARTMENT DESIGN.

1.5.1 **Location.** Habitability facilities, excluding medical and dental spaces, offices, and staterooms, make up about 20 percent of the arrangeable area of a ship and are typically distributed through the upper decks and deckhouse. Locations for habitability facilities are normally determined after spaces for higher priority systems, such as weapons, electronics, and machinery, are fixed; however, some locations may be unsuitable for habitability facilities.

1.5.1.1 **Noise.** Avoid locations near sources of loud noise, such as diesel generator rooms.

1.5.1.2 **Vibration.** Avoid locations with excessive vibrations, such as in the vicinity of the ship's propeller.

1.5.1.3 **Motion.** Avoid locations with excessive ship motion, such as the bow if subject to slam, or the extreme top of the superstructure.

1.5.1.4 **Access.** Avoid locations that are too inaccessible for running distributive systems or where inclined ladder access is precluded, such as down near the bilges.

1.5.1.5 **Proximity to Propulsion Plants in Nuclear Powered Warships.** For nuclear powered ships, any change to compartment arrangement (e.g., moving existing bulkheads), assigned compartment function (e.g., changing a storeroom or locker with assigned space number to a berthing area or office), or changes that result in new bulkhead or deck penetrations within the specified decks/frames delineated by NAVSEAINST 9210.4 are not permitted without prior NAVSEA approval.

1.5.1.6 **Tanks.** Avoid locations above fuel tanks and collecting and holding tanks (MSD).

1.5.2 **Boundaries.** Compartment configuration is an essential design constraint that shall be developed prior to developing an arrangement. Provide optimum configurations wherever practical. Many compartment boundaries are predetermined by overall ship general arrangement considerations.

1.5.2.1 **Bulkheads.** Provide habitability facilities with lightweight, flush, joiner-type bulkheads, except where structural bulkheads are required for other purposes. Ensure that bulkheads for spaces requiring privacy or for separating air conditioned spaces from non-air conditioned spaces are at least light-tight. Install bulkheads perpendicular to the baseline and either parallel or perpendicular to centerline to optimize producibility. Ensure that outside corners of bulkheads in passageways are rounded to prevent personnel from being injured should they inadvertently fall against the corners as the ship rolls.

1.5.2.2 **Shell and Deckhouse.** Where the shell or deckhouse forms part of a compartment boundary, ensure that the space arrangement conforms to the flare, tumble home, or other curvature and allow for structure and thermal insulation.

1.5.2.3 **Overhead.** Installation of distributive systems such as piping, wiring, and HVAC ducts should be minimized in living spaces, sanitary spaces, food service spaces, recreation spaces, lounges, and medical spaces. Where distributive systems are located in these spaces, distributive systems should be installed as close as practicable to the deck over in order to provide maximum headroom above the minimum requirements. These requirements shall not be less than 6 feet 5 inches on surface ships. The 6 feet 5 inches requirement is based on allowing a 95th percentile male crewmember (in shoes and helmet) to walk without hitting his head.

1.5.2.4 **Deck.** Provide flat, flush decks wherever practicable. Where ramps are required, ensure they have a 1:8 maximum slope. Where high-hats are required, ensure decks have steps and protective railings if greater than 9 inches.

1.5.3 **Access.** Compartment accesses have limited flexibility in location and require close coordination with the compartment configuration and arrangement. Ensure that access locations consider ship structure and avoid cutting main structural members.

1.5.3.1 **Door.** Provide a 26- by 75-inch (no sill) joiner door for normal access to habitability spaces, except for wet spaces or other spaces requiring a sill. Provide a 26- by 66-inch (9-inch sill) joiner door for wet spaces unless other compartment requirements or functions dictate the use of an alternative door design. Ensure that compartments occupied by 21 or more people have more than one means of egress, which may be other doors or a 25-inch diameter scuttle. Door swing may be either right- or left-handed and is normally into a compartment in order to avoid interference with passage traffic.

1.5.3.2 **Scuttle.** Scuttles are normally provided for emergency egress and may be located in bulkheads, decks, or overheads. Overhead scuttles require a vertical ladder for access.

1.5.3.3 Hatch. Hatches leading to other spaces are sometimes found in large living spaces. Ensure adequate clearance is provided for guardlines, or equivalent required protective barrier, around the hatch for safety. Additionally, shields shall be fitted on the underside of ladders in quarters. Similar shields, extending from the stringers to the overhead, shall be provided for the sides of ladders to crew living compartments, if there is no passageway between the ladder and the closest tier of berths.

1.5.3.4 Manhole. Compartments above tanks typically require manholes for access and gas-freeing the tank below. Each tank has two accesses (one for personnel access and one for ventilation) located at the top of the tank and spaced as widely apart as possible. Spaces over tanks will also be penetrated by fill and overflow piping and sounding tubes that may affect the arrangement of equipment.

1.5.4 Scantlings. Structural support members often have a major impact on the arrangement of a compartment by reducing the net arrangeable area by influencing the location of accesses and distributive systems. If scantlings are unknown, estimate their size and location and validate the estimate later.

1.5.4.1 Stiffeners. Structural bulkheads typically have periodically spaced “T” stiffeners on one side. Size and spacing of stiffeners may vary depending on load distribution.

1.5.4.2 Stanchions. Stanchions to carry vertical loads are often found in large compartments and in deck areas subdivided only by joiner bulkheads.

1.5.4.3 Longitudinals and Stringers. Longitudinals stiffen the underside of decks and, as the name implies, run longitudinally. Stringers run longitudinally along the shell or deckhouse following shell curvature.

1.5.4.4 Web Frames. Web frames, where provided, are deep members, spaced periodically and transversely circumscribing the shell. They are tied in to large transverse stiffeners on the underside of decks which can be the limiting factor in determining clear headroom within a space.

1.5.4.5 Miscellaneous. An assortment of other structural elements, such as bents, catapult troughs, and kingposts, may impact habitability facilities depending on ship type and compartment location.

1.5.5 Distributive Systems. Mechanical and electrical distributive systems may further constrain net arrangeable area. Allow space for these systems prior to arranging a compartment and validate the distributive system design periodically to guide and minimize their impact.

1.5.5.1 Ventilation. Anticipate space loss to large vent ducts for compartments bounded by machinery spaces and fan rooms. If compartments are provided with fan coil units, indicate on the arrangement drawing.

1.5.5.2 Piping. Plan for additional piping systems for compartments under wet spaces, above tanks, and along the shell.

1.5.5.3 Wireways. Plan for wireways and antenna cables for compartments near electronics spaces and in the superstructure.

1.5.6 Human Engineering. Many of the design practices discussed in this manual are based on human engineering principles and can assist the designer when encountering situations requiring human engineering considerations. See MIL-STD-1472 for further Human Engineering design criteria and principles.

1.5.6.1 Personnel. Design for the anthropometric dimensions and capabilities of the 5th percentile female to the 95th percentile male crewmember.

1.5.6.2 Standardization. Multiple compartments serving the same purpose, such as living spaces, should follow identical equipment selection and compartment configuration and arrangement practices.

1.5.6.3 Life Cycle. Ensure that the compartment configuration and arrangement takes into consideration the needs of the installer, operator, and maintainer in the various operating scenarios and environmental conditions expected in its life cycle.

1.6 EQUIPMENT DESIGN.

1.6.1 General. Shipboard habitability equipment, including furniture, is expected to function for sustained periods of time in conditions not experienced in shore facilities. For some items, such as the crew berth, function and design are specific to the Navy. In the general case, however, shipboard habitability equipment represents commercial or commercial marine equipment that has been upgraded for Navy service. The major difference between Navy and commercial furniture is that Navy furniture is constructed primarily of aluminum for weight control. Commercial furniture is usually constructed of steel or wood. The following paragraphs describe general shipboard performance requirements for use in selecting equipment. Part II, [Table 1-2](#) identifies common differences between commercial, commercial marine, and Navy equipment. These general requirements do not add or detract in any way from those in valid equipment drawings or specifications.

Table 1-2. Commercial and Navy Habitability Equipment Differences.

Requirement	Commercial	Commercial marine	Navy
Ship motion			
Foundation	N	Y	Y
Inclination	N	Y	Y
Positive latching	N	Y	Y
Battens	N	Y	Y
External design	N	Y	Y
Ship integration			
Minimum size and weight	N	P	Y
Hatchable	N	P	Y
Front access	N	P	Y
Electrical power	N	P	Y
EMI	N	N	Y
Equipment heat, noise, vibration	N	P	Y
Ship environment			
Vibration	N	P	Y
Variable services	N	P	Y
Temperature	Y	Y	Y
Water spray	N	Y	Y
Corrosion	P	Y	Y
Shock	N	N	Y
Security	P	P	Y
Safety			
Protective shields	P	P	Y
Interlocks	P	P	Y
Brittle materials	N	Y	Y
Passive fire safety	N	P	Y
Hazardous materials	P	P	Y
NOTES: N – Not generally considered P – Partially considered Y – Yes, required design feature			

1.6.2 **Ship Motion Requirements.** Equipment shall operate and survive in expected sea states at designed ship speeds. Ships at sea experience six kinds of motion, three translations (surge, sway, and heave), and three rotations (roll, pitch, and yaw). The combined effect of these motions can be complex and severe. In addition, with various loading conditions, ships may take on trim or list that can accentuate other motions.

1.6.2.1 **Foundation.** Ensure all equipment, except portable items, can be permanently mounted to a deck, bulkhead, dresser, shelf, or other structure. Ensure portable items have dedicated stowage locations and means of being secured. Special consideration should be given to items mounted on joiner bulkheads.

1.6.2.2 Inclination. Select items that remain operable when inclined to 15 degrees and undamaged when inclined to 45 degrees.

1.6.2.3 Positive Latching Mechanisms. Ensure that doors, drawers, and other hinged or sliding parts have positive latching mechanisms for both the closed and open positions. Bullet, bayonet, and magnetic catches are not considered to be positive latching mechanisms.

1.6.2.4 Battens. Ensure that shelves have battens and upward-flanged edges on open sides to retain their contents.

1.6.2.5 External Design. Select items that have smooth surfaces, rounded corners and projections, and protected switches and controls to minimize risk of injury to personnel or damage to equipment.

1.6.3 Ship Integration Requirements. Equipment installed in Navy ships shall be compatible with other ship systems. Lack of compatibility will incur additional installation costs that can easily exceed the cost of the equipment.

1.6.3.1 Size and Weight. Minimize equipment size and weight to reduce overall ship size and weight or to free up space and weight for other systems.

1.6.3.2 Hatchable. Ensure that equipment for surface ships can pass through a 26- by 66-inch door (with 8-inch radius corners) or a limiting hatch dimension to avoid the need for access cuts in the shell or other ship's structure. Larger items should be sectionalized if possible.

1.6.3.3 Front Access. Select equipment that can be operated, maintained, and repaired from the front in order to minimize total ship area and volume requirements and to facilitate maintenance.

1.6.3.4 Electrical Power. Select electrical equipment that uses either 440 Volt, 60 Hertz, 3-Phase AC, or 115 Volt, 60 Hertz, 1-Phase AC to be compatible with the power produced by the ship.

1.6.3.5 Electromagnetic Interference (EMI). Select equipment that operates within safe levels of radiated and conducted EMI (see MIL-STD-461).

1.6.3.6 Heat, Noise, and Vibration. Ensure that heat, noise, and vibration generated by equipment neither cause safety concerns nor adversely affect other equipment.

1.6.4 Shipboard Environmental Requirements. Ship environmental conditions are harsh and fluctuate widely. In addition, heavy usage, inexperienced personnel, and inadequate maintenance of equipment often combine to shorten expected life cycles.

1.6.4.1 Vibration. Select equipment that can withstand vibration at resonant frequencies (below 33 Hertz) for up to 2 hours (see MIL-STD-167-1).

1.6.4.2 Varying Service Conditions. Ensure that equipment can remain operable when subjected to higher or lower than designed water, steam, air, and electrical service conditions, and has safety devices installed to protect personnel and equipment when unacceptable operating conditions arise.

1.6.4.3 Temperature. Select equipment that is operable at ambient temperatures between 32 and 122 °F and at relative humidities greater than 95 percent.

1.6.4.4 Water Spray. Select equipment that can remain operable after exposure to water spray and has no noticeable residual water collection.

1.6.4.5 Corrosion. Use materials that are corrosion resistant. Coatings, where used, should be applied by the manufacturer and should be easy to clean and resist abrasion. Dissimilar metals should have compatible galvanic properties.

1.6.4.6 Shock. In general, habitability equipment is not required to undergo shock testing in accordance with MIL-S-901, but is required to be secured and arranged so as not to become a hazard. An exception is in troop living space furnishings, which shall meet Grade B shock in accordance with MIL-S-901 because troops are stationed in their living spaces during general quarters.

1.6.4.7 Security. Ensure that cabinets and lockers can be securely locked and resist forced entry.

1.6.5 Additional Safety Requirements.

1.6.5.1 Protective Shields. Provide protective shields at burn or scald hazards.

1.6.5.2 Safety Interlocks. Provide electrical and mechanical interlocks to ensure personnel safety when performing maintenance or repairs.

1.6.5.3 Brittle Materials. Restrict use of brittle materials. Suitably protect or reinforce essential glass, plastic, fiberglass, and cast metal parts. The use of laminated (safety) glass in accordance with ANSI/SAE Z26.1 is permitted on a limited basis for mirrors, display cases, book cases, and bulletin boards. Wire mesh reinforced glass in accordance with ASTM C1036 should be used in glass door or large display window applications.

1.6.5.4 Passive Fire Safety. Use materials with passive fire protection to minimize smoke development, flame spread, and toxicity, and promote fire retardancy. Wood and wood products are prohibited, except in mine warfare ships. The use of transparent plastics is generally discouraged in habitability spaces because they will deform at high temperatures or burn in exposure to flame. The use of transparent plastics, except for polycarbonate, is restricted to the following special applications:

- a. Light diffuser panels
- b. Mirrors (in sanitary spaces and physical fitness spaces only)
- c. Food service area sneeze shields
- d. Ship store showcases

1.6.5.5 Hazardous Materials. Avoid the use of materials that are determined to be health hazards, such as mercury, asbestos, and cadmium. See OPNAVINST 5100.19 for safe handling of hazardous materials on Navy ships. Also see T9070-AL-DPC-020/077-2 for NAVSEA hazardous material avoidance process.

1.7 COLOR SCHEMES.

1.7.1 Purpose. Well-chosen color schemes improve the appearance of habitability and other shipboard facilities and stimulate their design functions.

1.7.2 Components. Color schemes are put together with consideration of colors, patterns, and textures of materials for bulkheads, overheads, decks, furniture, and accessories. This includes items such as paint, tile, carpet, upholstery, curtains, plastic laminate, and hardware.

1.7.3 Numbers. The number of different color schemes should be large enough to provide personnel with a change of environment during their daily routine, but small enough to keep logistical problems associated with repair and replacement of materials manageable. Provide officers, CPO, and crew with different color schemes for their respective berthing, sanitary, recreation, and messing spaces. Provide additional color schemes for community spaces that are used by all personnel, such as passages, offices, and other work and utility spaces.

1.7.3.1 Definition of Change. A change in color scheme is a change in bulkhead or deck color and an appropriate variation in accent colors. A small number of bulkhead and deck colors can be combined with a greater variety of accent colors to provide a sufficient number of different color schemes.

1.7.3.2 Multiple Color Schemes. Multiple spaces of the same type that are not subject to general ship traffic, such as officer staterooms or crew living spaces, may use one color scheme for all spaces. Multiple spaces with general ship traffic, such as passages, should have two or more different schemes to provide variety.

1.7.4 Objectives. In general, habitability space color schemes should be cheerful, clean, comfortable, lend a natural appearance to the skin, and minimize the institutional look. Use socially stimulating color schemes in active spaces, such as messrooms, and quiet, restful schemes in passive spaces, such as berthing spaces. Use neutralizing color schemes in spaces that have more than one purpose as opposed to mixing too many colors. Since most shipboard compartments are of minimal size, use colors that make the space appear larger and cause projecting structure and furnishings to recede into the background. Care must be taken to ensure that no color scheme is adopted that already has a coded or population stereotype associated with it (for example: purple associated with fuels or red and yellow associated with danger or caution).

1.7.5 Color Selection Requirements. Individual manufacturers should be consulted to obtain current color samples, since new colors and patterns are continually being introduced while old ones are discontinued. Standard color chips can be reviewed in FED-STD-595. When practical, allow COs or PCOs to select color schemes (from a small number of optional schemes) for senior officer quarters.

1.7.5.1 Visibility. A proper combination of color and light is necessary in order to see well. Light colors provide good seeing conditions without requiring high levels of illumination. Darker colors need higher levels of illumination. See DOD-HDBK-289 for detailed information on illumination and recommended illumination levels to achieve various objectives. Also, colors appear different under varied lighting conditions. When developing color schemes, simulate shipboard compartment lighting conditions to the maximum extent possible.

1.7.5.2 Maintenance. Select paints and materials that are easy to clean and resist damage. Avoid materials with heavily textured surfaces. Apply paints and materials in a manner that does not require extreme care or skill to refurbish. Philosophies of using dark colors because they do not show dirt and soil are not necessarily valid. Dirt, soil, and damage should not be overlooked. Paints and materials are available that are highly resistant to discoloration or damage and are easy to clean and replace. Fabric backed vinyl, used for decorative bulkhead sheathing, does not exhibit the durability of either high pressure plastic laminate or PVC/aluminum laminate and is not recommended for use. Fabric backed vinyl decorative covering shall not be used in new construction; it also shall not be installed under any conditions in either commissary spaces or wet spaces.

1.7.5.2.1 Repairables. Since colors are periodically discontinued by manufacturers, small quantities of replacement items, such as deck tiles and sheathing, should be carried on board to ensure an exact match when repairs are made.

1.7.5.2.2 Consumables. Items such as curtains and bedspreads will be replaced when necessary. These items do not need to be carried on board. These items can be used advantageously for color accents.

1.7.5.3 Numbers of Colors. Avoid using too many different colors for coverings, paint finishes, or fabric, as this only increases logistical problems, requires too many different cleaning materials or procedures, and requires special tools to clean or refurbish compartments or components. Limit materials that are carried on board, such as paints and deck tile, to no more than 6 to 10 different colors each.

1.7.6 Applications Guidelines. In selecting colors for interior finishes, it is important to preserve sufficient reflectance to maintain adequate light distribution throughout the space. Use surface reflectance values in the following ranges: decks, 15 to 35 percent; bulkheads, 40 to 60 percent; overheads, 70 to 80 percent; furniture, 25 to 50 percent; and accessories, 15 to 60 percent. Bulkheads and decks are the primary finishes to select and are the most critical to logistical concerns. Furniture finishes for case items, such as lockers, cabinets, and desks, should be standardized. Furniture finishes for tables, chairs, and accent items, such as curtains, can be more widely varied as necessary for accent and interest.

1.7.6.1 **Bulkheads.** Select a single color paint scheme for most bulkhead treatments in order to provide a feeling of expanse. Use a light shade of the basic color family that has been selected. Use the same color on doors and door frames; coamings may be a darker shade. If pre-colored bulkhead coverings are used instead of paint, they too should be of a single color. In large compartments (over 1,000 square feet), one bulkhead may be of a slightly different shade of the basic color family or may be a woodgrain or other pattern in order to add interest to the visual environment. Avoid using very dark woodgrain panels with light painted surface treatments.

1.7.6.2 **Overheads.** Paint compartment overheads off-white, blended to match the basic color family represented by the bulkhead color. If overheads are not sheathed, paint structural elements, piping, ceiling-mounted ducting, etc., the same color as the overhead in order to make them less intrusive.

1.7.6.3 **Deck.** Deck colors should be a medium shade from the same color family used on the bulkheads. If tile is used, select fine-grained patterns. If carpet is used, select fine-grained patterns or solid colors. If tile is used on one part of a compartment and carpet on another part, the two should be compatible in color and pattern. Avoid large, prominent deck covering patterns since they appear busy and attract too much attention. Where two or more spaces combine to form a complex, as in a senior officer's cabin and stateroom, a single deck color may be used throughout to provide a feeling of expanse.

1.7.6.4 **Built-In Cabinets.** Treat built-in cabinets with a color or woodgrain that causes them to remain neutral or recede and reduce their apparent size in the space. The larger the visual area represented by cabinets, the lighter the color should be. Paint cabinets either the same color as the bulkheads or a color slightly darker, but compatible with basic bulkhead color family characteristics.

1.7.6.5 **Furniture.** For structure of furniture, use the same or a similar color as any built-in cabinetry within the space. Use a light to medium shade on desk tops to minimize the brightness contrast between tops and any printed materials that may be placed on them. A single color scheme may be used with compartments having woodgrain finish on bulkheads or on built-in cabinets. Match or blend woodgrain furniture with bulkhead or cabinet woodgrain. Avoid using two or more boldly patterned grains in the same space.

1.7.6.6 **Upholstery.** Select a color that is compatible with the basic color family chosen. Upholstery may be either lighter or darker than the bulkhead color, or be a contrasting complementary color to provide accent to the general decor. Use either solid or patterned colors. Select small, fine-grained patterns as opposed to large, prominent patterns with highly saturated hues. If solid colors are selected, use no more than two different colors within the same compartment.

1.7.6.7 **Curtains and Drapes.** Select either a solid color or patterned design. In the latter case, the pattern should be small and fine-grained. Avoid using large, exotic patterns. The color of curtains or drapes may be selected from an analogous or complementary hue. If the curtains or drapes occupy a large visual area, use analogous colors. If the visual area covered is small, select complementary colors to provide accent and visual interest.

1.7.6.8 **Accessories.** Items such as table lamps, waste baskets, etc., should possess colors that are compatible with the basic color family chosen. Lamps are of interest and may be of a complementary color, while the wastebasket, being of less interest, should be of an analogous color or of the same woodgrain as any other woodgrain selected for the compartment.

1.7.6.9 **Hardware and Trim.** Where metal is used for cabinet handles, trim, etc., the color of the metal should be compatible with the basic color family. Brass and gold are associated with warm colors, while aluminum and silver are associated with cooler colors. Avoid using highly polished metal trim; use antique or satin-finish. Also, avoid using large amounts of metal surface and trim since this creates an institutional appearance.

CHAPTER 2 OFFICER LIVING SPACES

2.1 GENERAL.

2.1.1 Number. Ship officers typically constitute 6 to 10 percent of total ship's company accommodations. Troop officers typically constitute 6 to 10 percent of total Marine detachment.

2.1.2 Location. In general, locate officer living spaces on the main deck or above in an area, designated as "officer country", that is not subject to enlisted personnel traffic. One exception is the Executive Officer living spaces which should be readily accessible to the crew. In surface combatants, provide separate officer country fore and aft for better survivability.

2.1.3 Types of Officers.

a. Ship's Company:

- (1) Commanding Officer (CO)
- (2) Executive Officer (XO)
- (3) Department Heads (Engineering, Supply, Combat Systems, Operations, Deck, Navigation, Medical, and Dental)
- (4) Junior Officers

b. Staff:

- (1) Flag, Group, Squadron, or Unit Commander
- (2) Chief-of-Staff
- (3) Staff Officers

c. Detachments (Air Wing, Helo, Marine Guards, Amphibious Assault Unit, etc.)

2.1.4 Types of Living Spaces.

2.1.4.1 Sea Cabin. Provide sea cabins for COs and Flag Officers in the vicinity of their at-sea command stations (i.e., Bridge, pilot house/CIC, Tactical flag command center), except where their staterooms are already near these stations.

2.1.4.2 Cabin and Stateroom. Provide a cabin and stateroom for COs (destroyers and larger ships), XOs (carriers, amphibious assault ships, and large auxiliaries), and staff detachment officers of equivalent rank.

2.1.4.3 Single Stateroom. Provide single staterooms for COs (small auxiliaries and patrol craft), XOs (cruiser and destroyer ships), department heads (carriers, amphibious assault ships, and large auxiliaries), and staff and detachment officers of equivalent rank.

2.1.4.4 Double Stateroom. Provide double staterooms for XOs (frigates and small ships), department heads (cruiser and smaller ships), and all junior officers.

2.1.4.5 Triple Stateroom. Provide triple staterooms for junior officers in ships that are too tightly constrained to allow officers to be berthed in single and double staterooms.

2.1.4.6 Bunkroom (Maximum of Six Junior Officers). Provide bunkrooms in surface ships that are too tightly constrained to allow officers to be berthed in single and double staterooms.

2.1.4.7 Transient Berthing. Provide a triple stateroom or a bunkroom for officer transients in ships that receive a steady influx of transients. A maximum of eight berths may be provided in transient officer bunkrooms.

2.1.4.8 Surge Berthing. Provide a sleeping surface within existing troop officer living spaces except where surge officers are berthed in other spaces that are convertible to surge berthing.

2.1.5 Functions of Living Spaces.

- a. Sleeping
- b. Dressing
- c. Personal stowage
- d. Personal hygiene
- e. Office work
- f. Conferences
- g. Dining (in cabins)

2.1.6 Related Spaces.

- a. Sanitary spaces (private and semi-private T/S, bath, and community sanitary space)
- b. Messrooms and lounges
- c. Baggage stowage
- d. Linen lockers
- e. Cleaning gear lockers
- f. Passages

2.2 OUTFIT AND FURNISHINGS.

2.2.1 Sleeping Surfaces.

- a. Beds – Flag, CO, or XO staterooms with adjoining cabins
- b. Transom berths – sea cabins and single staterooms without cabins (department heads and above)
- c. Single berths – single staterooms
- d. Double berths – double staterooms and bunkrooms
- e. Three-High berths – junior officer and transient officer triple staterooms

2.2.2 Modular Furniture Units. For modular furniture units, see Part II, [Table 2-1](#) and Part II, [Figure 2-1](#).

Table 2-1. Modular Furniture Units (see [Figure 2-1](#)).

Modular unit number	Name	Size	Ownership
5	Long wardrobe	24-inch	Shared
12	Short wardrobe and file section	24-inch	^{1/}
14	Secretary bureau ^{2/}	24-inch	^{1/}
15	Secretary bureau ^{2/}	36-inch	Individual
16	Drawer, locker section	36-inch	Individual
N/A	Lavatory ^{3/}	24-inch	Shared
<p>NOTES:</p> <p>^{1/} Individual for ship’s company and senior troop officers. Shared for troop junior officers.</p> <p>^{2/} Secretary bureau shall include drop-leaf unit, light, and safe.</p> <p>^{3/} Provide in staterooms and bunkrooms without adjoining private baths. Lavatory features shall include: CRES bowl, mirror, light, toilet case, electrical outlet, soap dish, tumbler and toothbrush holder, and faucet.</p>			

2.2.3 **Modular Furniture Groups.** For modular furniture groups, see Part II, [Table 2-2](#). For selection of modular units associated with the furniture group number, see Part II, [Figure 2-1](#). For selection of furniture group number associated with the type of stateroom or cabin, see Part II, [Figures 2-2](#) through [2-8](#).

Table 2-2. Modular Furniture Groups.

Furniture group number	Compartment type
1	Single stateroom
2	Single stateroom
3	Double stateroom
4	Not used
5	Single stateroom
6	Sea cabin
7	Double stateroom
8	Single stateroom

2.2.4 **Accessory Furnishings.**

- a. Berth accessories (curtains, ladder, lee rail stowage clips, light, mattress, and spring unit)
- b. Bookrack (or built-in bookshelves)
- c. Chair (arm, armless, and lounge)
- d. Coat hooks (or coat and hat rack)
- e. Curtains (for airports or fixed lights)
- f. Desk (single- or double-pedestal, flat top)
- g. Grabrod (for access to upper berth)
- h. Key cabinet
- i. Locker, table leaf
- j. Mirror, full-length
- k. Safe locker
- l. Shelf, utility
- m. Stowage, built-in (above modular units)
- n. Tables (coffee, corner, end, dining, night, serving, and sideboard)

2.3 **ARRANGEMENT PRACTICES.**

Approximate sizes of cabins, staterooms, and bunkrooms are shown on Part II, [Figure 2-2](#) through [2-8](#).

2.3.1 **Single Staterooms for Small Ships (see Part II, [Figure 2-2](#), Modular Group 8).**

2.3.1.1 **Berth.** Locate berth/bed away from passages and other sources of intermittent noise. Orient berths primarily longitudinally; however, athwartships orientation may be used but shall be limited to not more than 30 percent of the berths where compartment arrangement is improved. Avoid locating modular furniture in way of berth drawers.

2.3.1.2 **Lavatory.** Orient lavatory facing forward or aft and position it away from berth and secretary bureau units to avoid splash from lavatory bowl. In adjacent staterooms, group lavatories back-to-back, where practicable.

2.3.1.3 **Secretary Bureau.** Orient modular unit 14 (see Part II, [Figure 2-1](#) for identification of modular unit) facing forward or aft to reduce the effects of ship roll when using a drop-leaf desk. Provide clear working and chair area with drop-leaf open. On small ships only, provide chair tie-downs at locations where chairs are to be secured for rough weather.

2.3.1.4 **Long Wardrobe.** Locate modular unit 5 (see Part II, [Figure 2-1](#) for identification of modular unit) near the door for easier access to outerwear.

2.3.1.5 **Bookrack.** Locate the bookrack adjacent to, but above, the lavatory, and position lavatory accessories (towel rack, tumbler, and toothbrush holder) under the bookrack.

2.3.1.6 **Access.** Orient the door so that it swings into the space and towards a bulkhead to avoid interference with passageway traffic.

2.3.1.7 **Furniture Clearance.** Position deck-mounted furniture about 1 inch from bulkheads to ensure adequate welding clearance.

2.3.1.8 **Sheathing and Carpeting.** Decorative bulkhead and overhead sheathing and carpeting are authorized in senior officer living spaces only.

2.3.2 **Double Staterooms for Small Ships (see Part II, [Figure 2-2](#), Modular Group 7).** Arrangement practices for small ship single staterooms apply to small ship double staterooms with the following addition: separate secretary bureaus with at least one modular furniture unit between bureaus to provide adequate elbow room.

2.3.3 **Single Staterooms for Mid-Size and Large Ships (see Part II, [Figure 2-3](#), Modular Group 1).** Arrangement practices for small ship single staterooms apply to mid-size and large ship single staterooms. The secretary bureau is larger, as is net walking area.

2.3.4 **Double Staterooms for Mid-Size and Large Ships (see Part II, [Figure 2-3](#), Modular Group 3).** Arrangement practices for small ship double staterooms apply to mid-size and large ship double staterooms. The secretary bureaus are larger, as is net walking area.

2.3.5 **Triple Staterooms for All Ships (see Part II, [Figure 2-4](#), Modular Group 7 Modified).** Arrangement practices for mid-size and large ship double staterooms apply to triple staterooms. The long wardrobe is larger, as is net walking area.

2.3.6 **Bunkrooms (Ship's Company) (see Part II, [Figure 2-4](#), Modular Group 7).** Arrangement practices for staterooms apply to bunkrooms with the below modifications.

2.3.6.1 **Furniture.** Berth and modular furniture unit requirements for four- and six-person bunkrooms are double and triple those for double staterooms, respectively, except that bookracks are not installed and only one lavatory is provided for each bunkroom.

2.3.6.2 **Functional Area Separation.** Isolate sleeping area from the working area using modular furniture units in order to minimize noise to sleepers.

2.3.7 **Troop Officer Bunkrooms (see Part II, [Figure 2-5](#), Modular Group 7).** Troop officers are Marines that are riding the ship either in an extended deployment or point-to-point mode. Their mission is usually linked to an amphibious assault. Except for the most senior ranks, extended deployment troop officers are berthed in bunkrooms and are provided with roughly half the modular furniture units that Navy officers get since they have less administrative workload and different uniforms and do not require as much stowage volume. Surge troop officers are provided with a sleeping surface only. All other arrangement practices for bunkrooms apply.

2.3.8 **Department Head Staterooms for Mid-Size and Large Ships (see Part II, [Figure 2-6](#), Modular Group 2).** Arrangement practices for small ship single staterooms apply to mid-size and large ship department head staterooms with the below modifications.

2.3.8.1 **Desk.** Orient desk facing forward or aft and position the bookrack and safe locker over desk, with light mounted under bookrack. Locate the desk close to the transom berth to facilitate group meetings. Provide adequate clearance for chair.

2.3.8.2 Transom Berth. Locate transom berth away from passage for noise considerations. Allow adequate clearance for persons seated in the transom berth and for drawers under the berth.

2.3.9 CO Stateroom/XO Stateroom for Small Ships (see Part II, [Figure 2-6](#), Modular Group 2). Arrangement practices for department head staterooms in mid-size and large surface ships apply with the below modifications.

2.3.9.1 Special Functions. These living spaces have the additional functions of being conference rooms. Provide lounge furniture, decorative bulkhead and overhead sheathing, carpeting, and a private bath. Also, install a computer workstation, special telephone, and Interior Communication (IC) service in CO and XO living spaces.

2.3.9.2 Location. CO living spaces shall be located, based on tradition, in the forward deck house, starboard side. XO living spaces shall be widely separated from CO living spaces and ensure that the XO is readily accessible to the crew.

2.3.10 XO, Squadron, and Unit Commander Living Spaces on Large Ships (see Part II, [Figure 2-7](#), Modular Group 2).

2.3.10.1 Living Spaces. Living spaces for XO, Squadron, and Unit Commander typically include a stateroom, cabin, and private bath. Install carpet and bulkhead and overhead sheathing throughout these spaces.

2.3.10.2 Stateroom. XO, Squadron, and Unit Commander staterooms shall include a bed, night table, and lounge chair, in addition to modular group 2 as shown on Part II, [Figure 2-7](#). Provide curtains at fixed port lights and airports.

2.3.10.3 Cabin. XO, Squadron, and Unit Commander cabins shall include a conference table, executive desk, computer workstation, television, and lounge furniture. Orient tables and desk with long axis athwartship. Orient lounge furniture to best suit the arrangement.

2.3.11 CO Sea Cabin (see Part II, [Figure 2-6](#)). Sea cabins are scaled down versions of senior officer staterooms. Sheathing and carpet may be installed. Sanitary fixtures, including the lavatory and toilet, may be within the sea cabin. All arrangement practices for department head staterooms apply to sea cabins.

2.3.12 CO/Flag Living Spaces on Large Ships (see Part II, [Figure 2-8](#), Modular Group 5).

2.3.12.1 Living Spaces. CO/Flag living spaces on large ships typically include a stateroom, cabin, and private bath. They also include a separate galley or pantry adjacent to the cabin. This ensures provision for private dining and conferences. Size spaces and select furnishings appropriate to the rank and responsibilities of these individuals. Install carpet and bulkhead and overhead sheathing throughout these spaces. Although typical orientations are shown for all furnishings on Part II, [Figure 2-8](#), the negative effects of ship motion are so small in large ships that any orientation is acceptable.

2.3.12.2 Stateroom. CO/Flag staterooms shall include a bed, night tables, and lounge chair in addition to modular group 5 as shown on Part II, [Figure 2-8](#). Provide curtains at fixed port lights and airports.

2.3.12.3 Cabin. CO/Flag cabin shall include a dining/conference table, sideboard, executive desk, computer workstation, television, and lounge furniture. Orient tables and desk with long axis athwartship. Orient lounge furniture to best suit the space configuration.

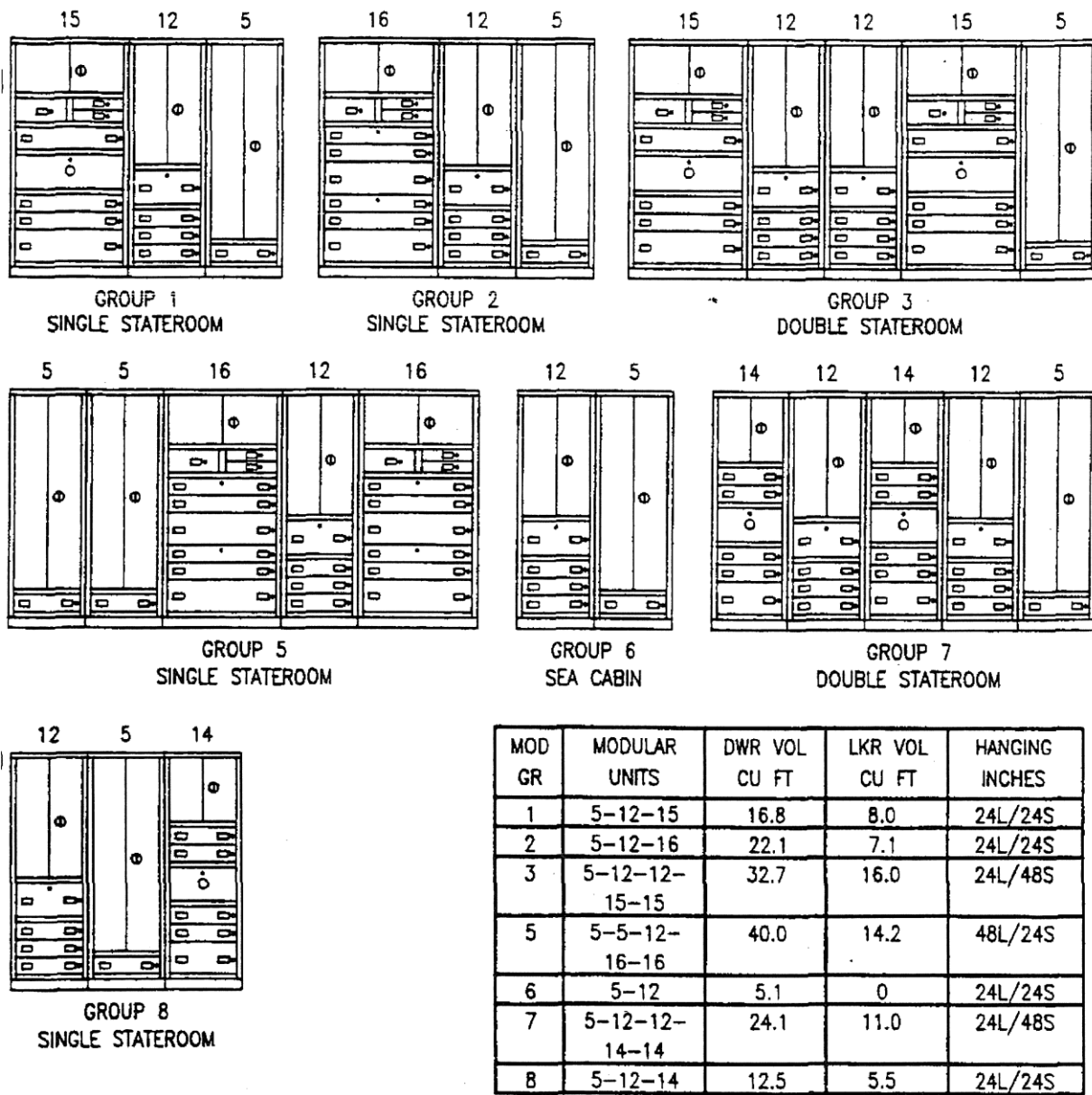

MOD UNIT	TITLE	WIDTH INCHES	DWR VOL CU FT	LKR VOL CU FT	HANGING INCHES	NAVSEA DWG NO.
5	WARDROBE LONG	24	0.9	0	24 LONG	805-1622993
12	WARDROBE AND FILE SECT	24	4.2	0	24 SHORT	805-1636403
14	SECRETARY BUREAU	24	7.4	5.5	0	805-1636410
15	SECRETARY BUREAU	36	11.7	8.0	0	805-1637639
16	DRAWER, LOCKER SECT	36	17.0	7.1	0	805-1637670

Figure 2-1. Modular Furniture Groups.

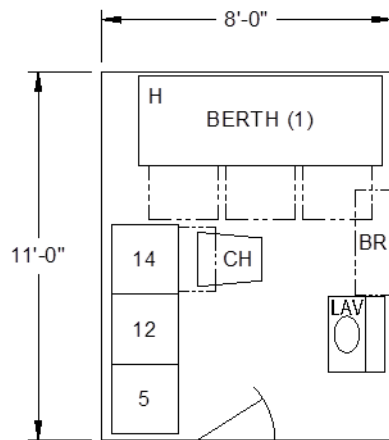

SINGLE STATEROOM
MODULAR GROUP 8
88 SQ FT GROSS AREA

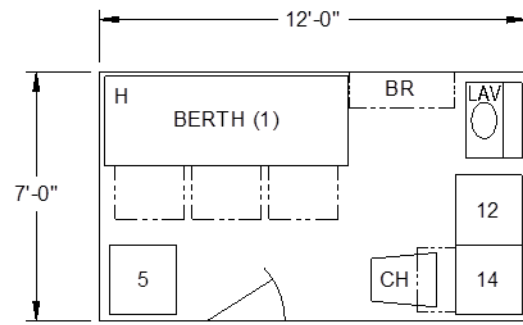

SINGLE STATEROOM
MODULAR GROUP 8
84 SQ FT GROSS AREA

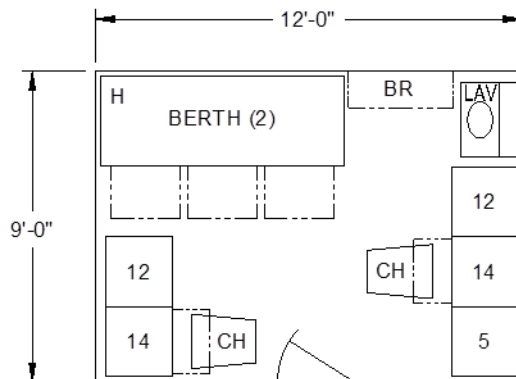

DOUBLE STATEROOM
MODULAR GROUP 7
108 SQ FT GROSS AREA

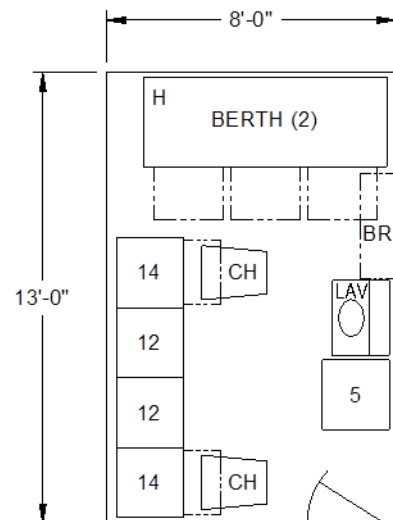

DOUBLE STATEROOM
MODULAR GROUP 7
104 SQ FT GROSS AREA

Figure 2-2. Typical Single and Double Stateroom Arrangements.

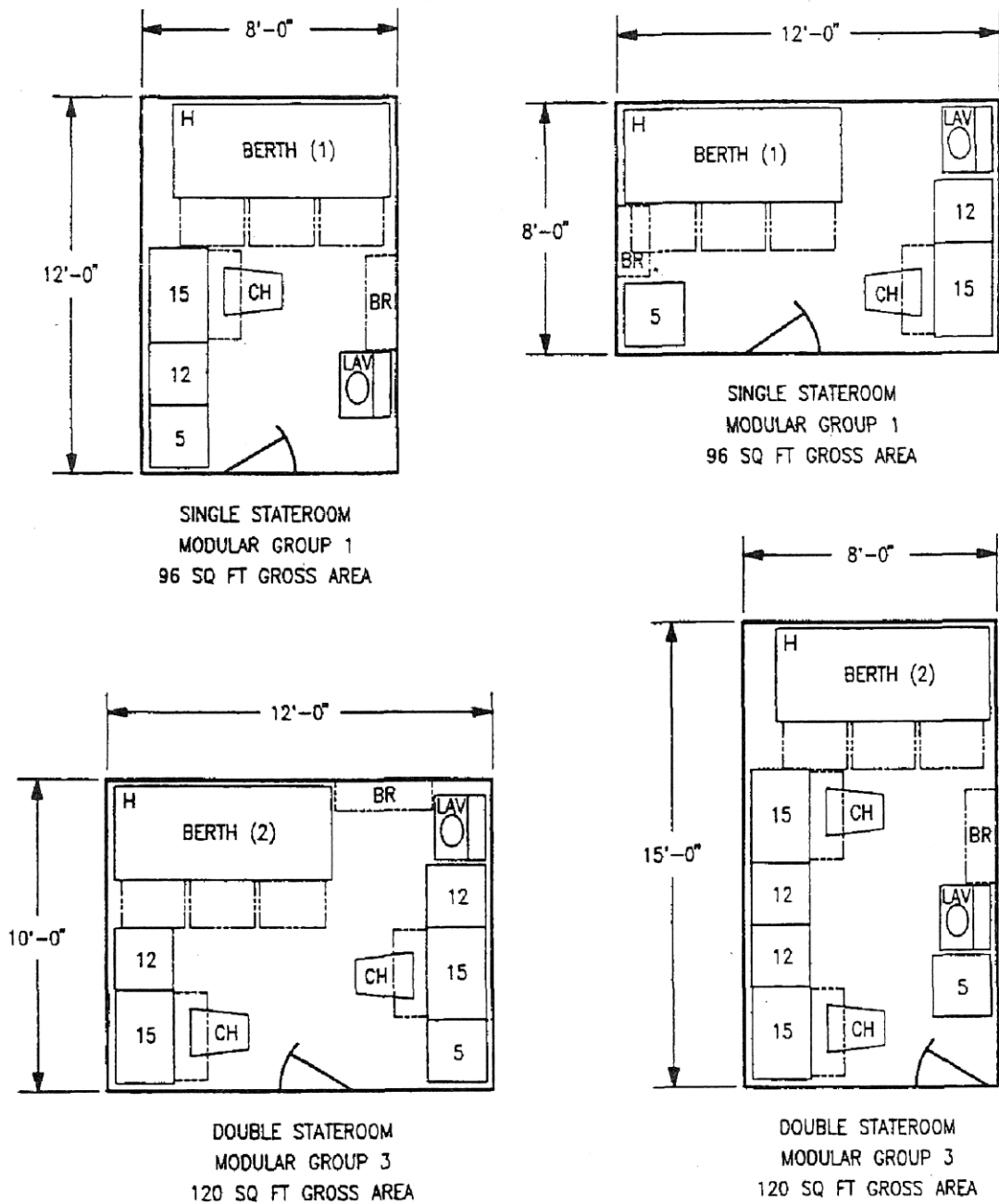
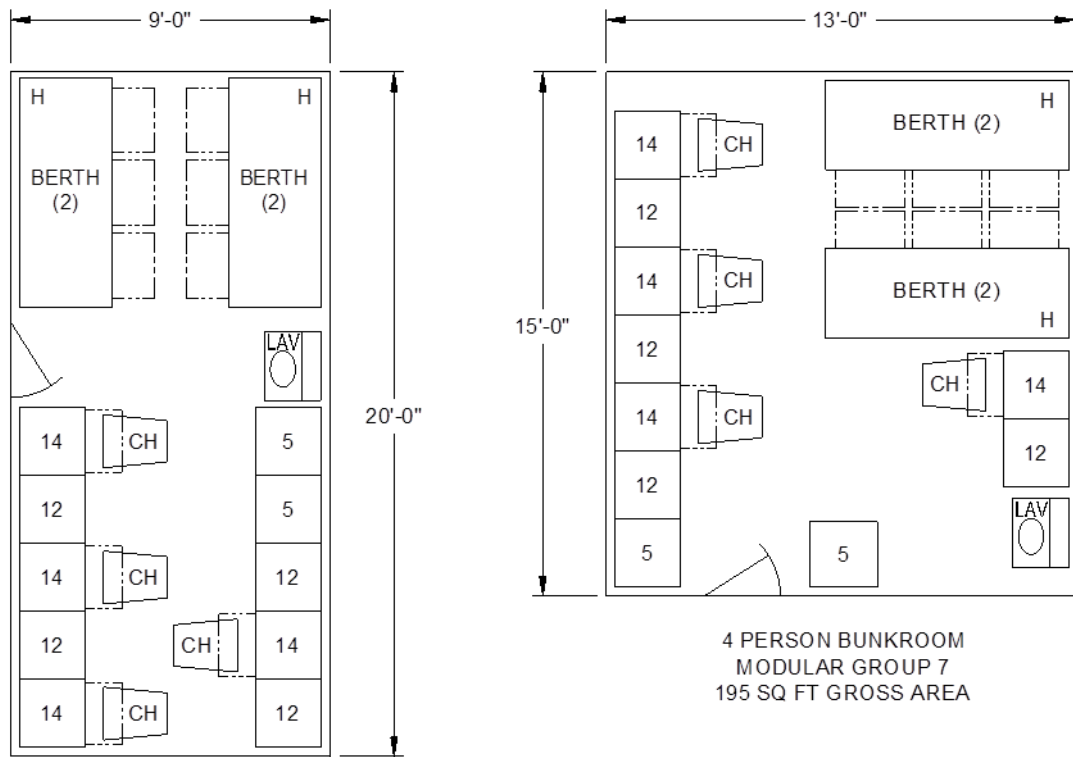
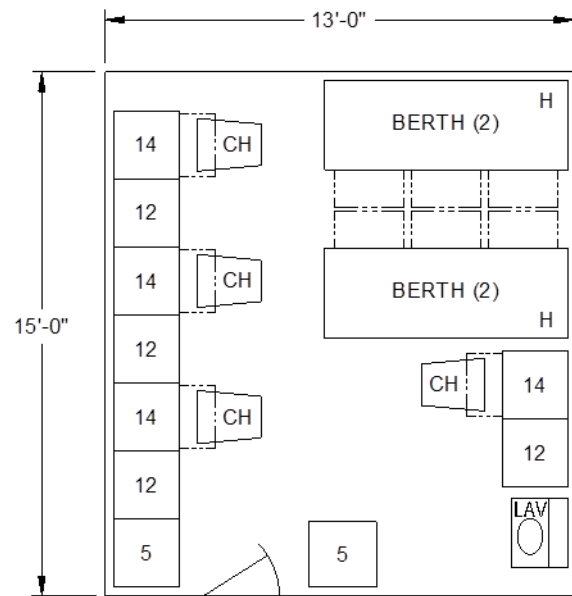

Figure 2-3. Typical Single and Double Stateroom Arrangements.



4 PERSON BUNKROOM
MODULAR GROUP 7
180 SQ FT GROSS AREA



4 PERSON BUNKROOM
MODULAR GROUP 7
195 SQ FT GROSS AREA

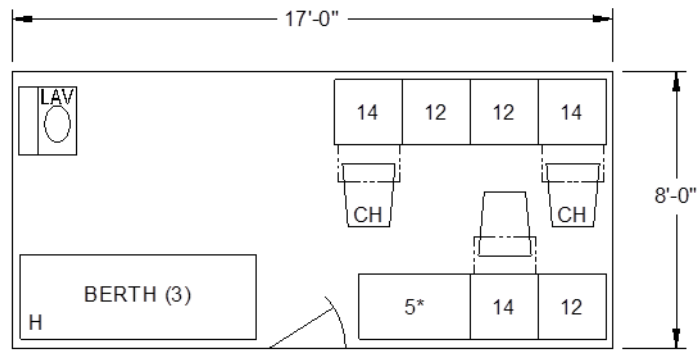

TRIPLE STATEROOM
MODULAR GROUP 7 MODIFIED
136 SQ FT GROSS AREA
* UNIT 5 MODIFIED TO 36 INCHES WIDE

Figure 2-4. Typical Triple Stateroom and Bunkroom Arrangements.

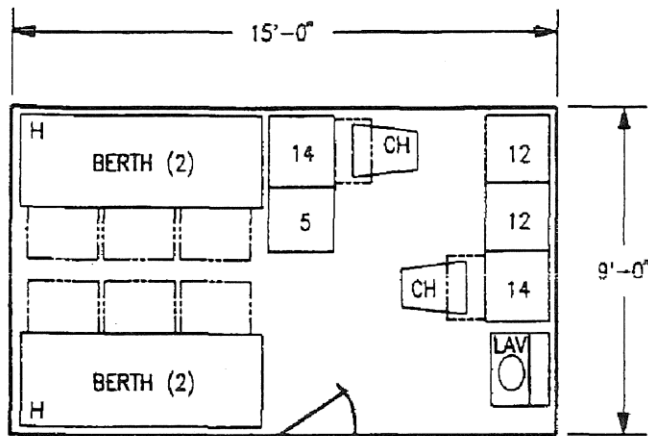

4 PERSON BUNKROOM
MODULAR GROUP 7
135 SQ FT GROSS AREA

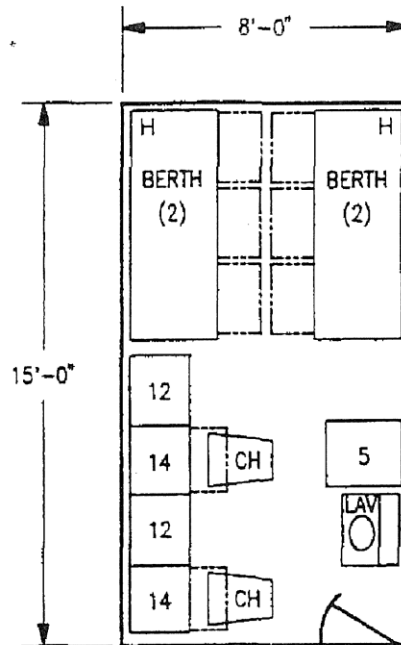

4 PERSON BUNKROOM
MODULAR GROUP 7
124 SQ FT GROSS AREA

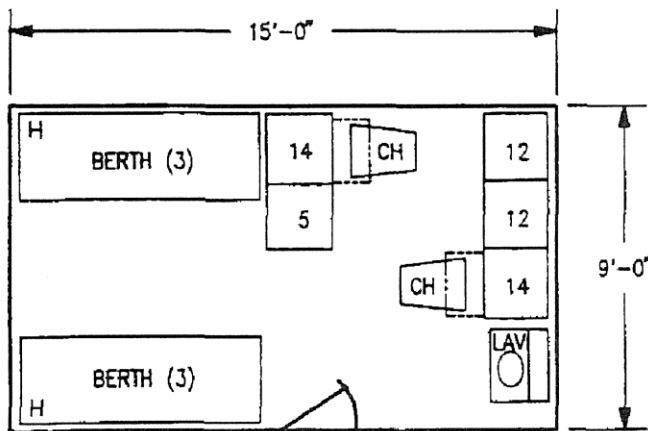

4 PERSON BUNKROOM
PLUS 2 SURGE
MODULAR GROUP 7
135 SQ FT GROSS AREA

Figure 2-5. Typical Troop Officer Bunkroom Arrangements.

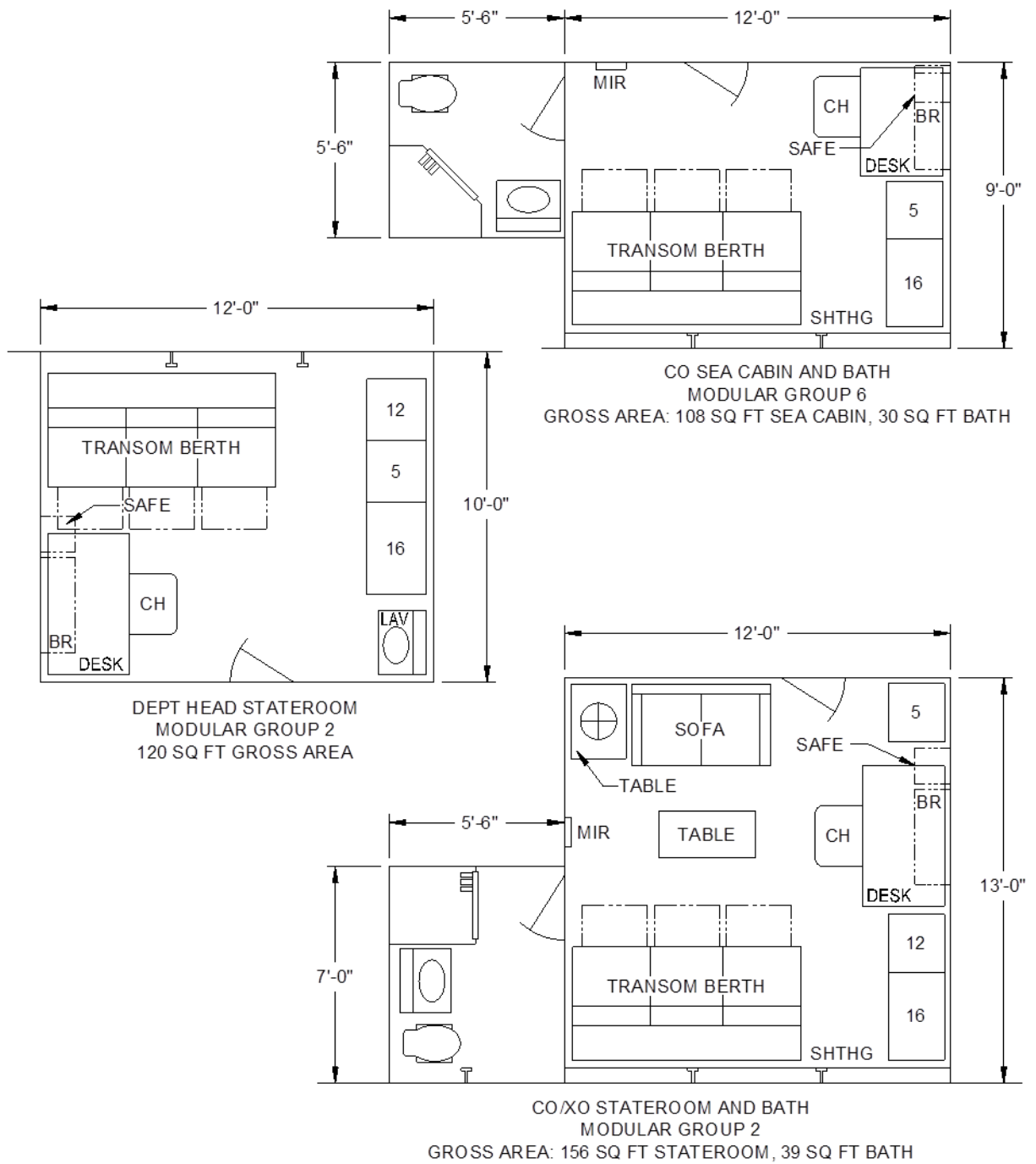
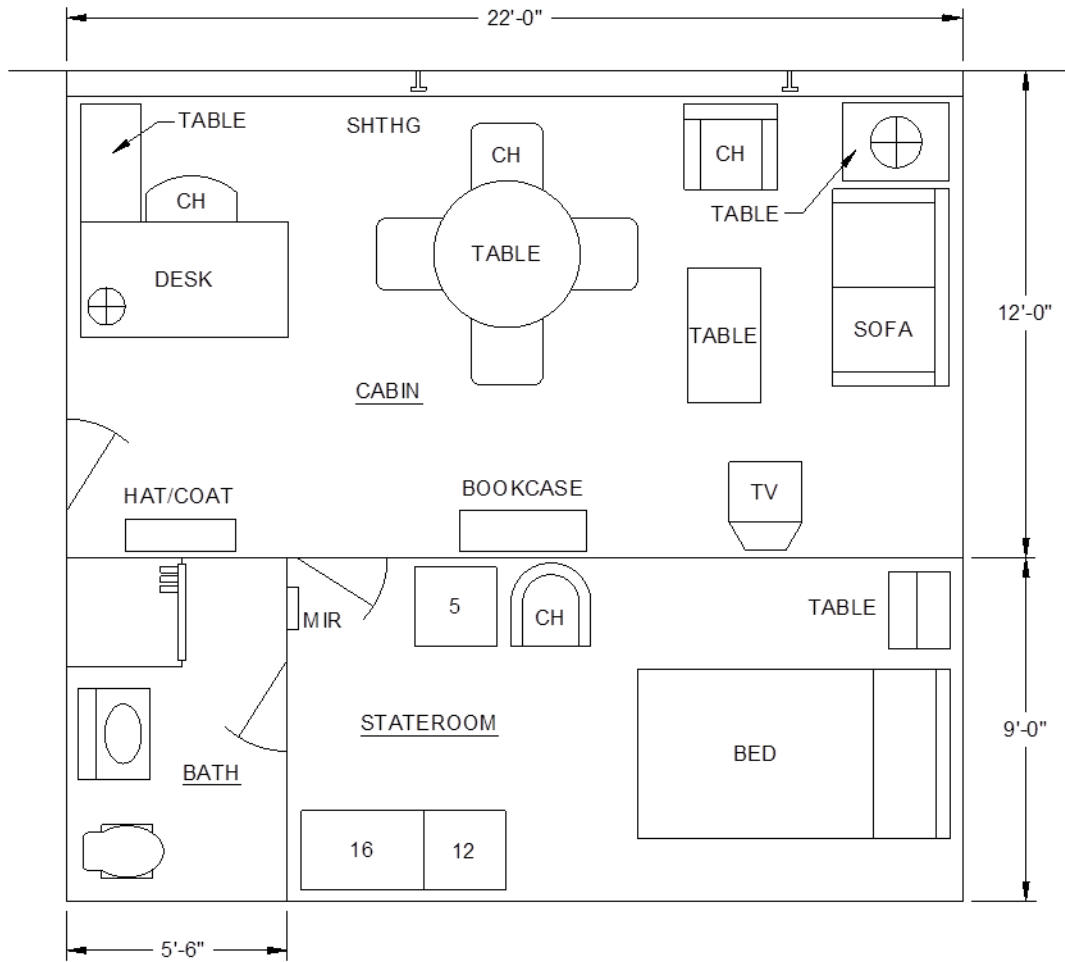
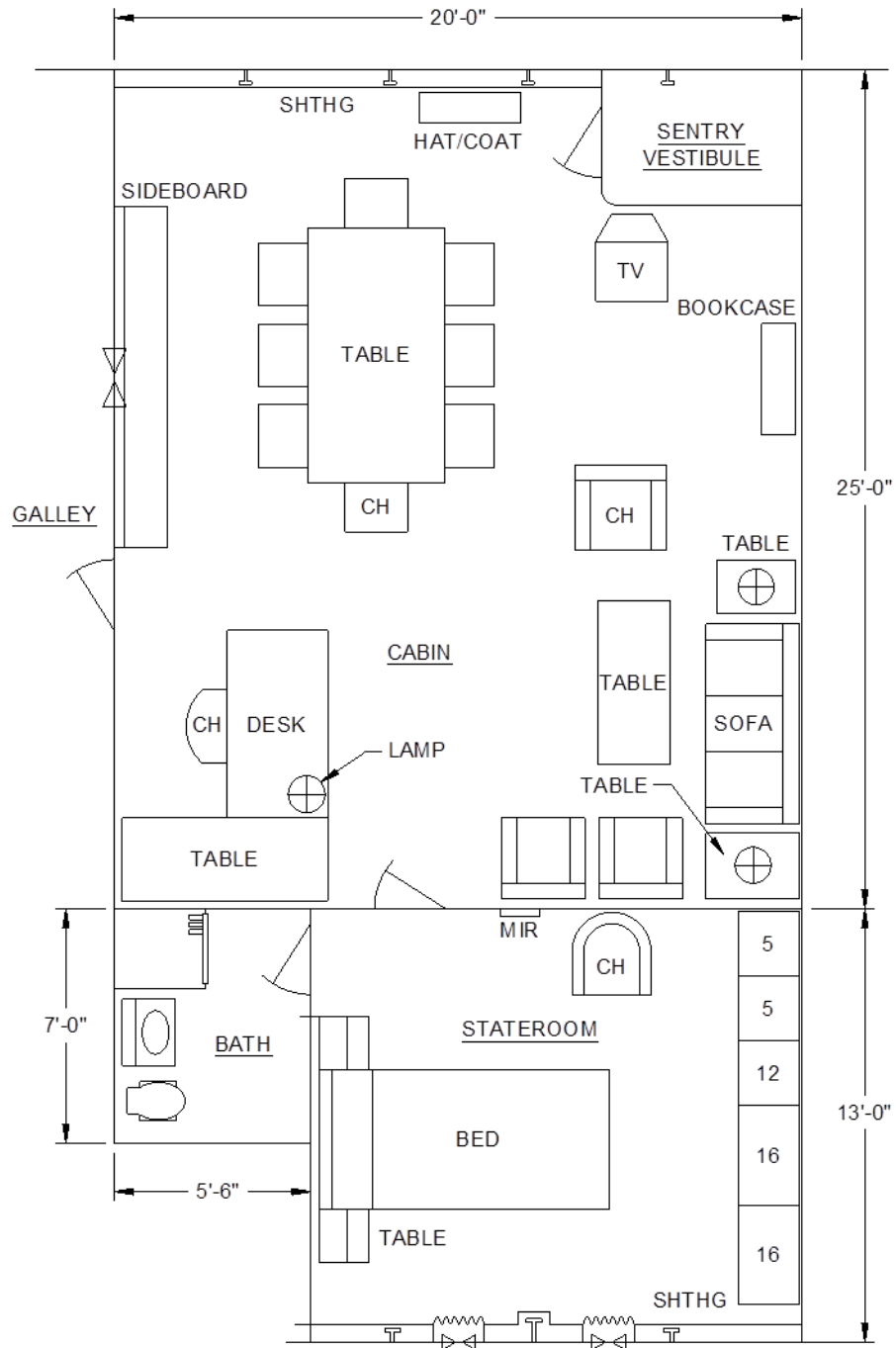

Figure 2-6. Typical Senior Officer Living Spaces.



XO, SQUADRON, AND UNIT COMMANDER CABIN, STATEROOM, AND BATH
 MODULAR GROUP 2
 GROSS AREA: 136 SQ FT STATEROOM, 264 SQ FT CABIN, 49 SQ FT BATH

Figure 2-7. Typical Executive Officer, Squadron, and Unit Commander Living Spaces.



CO/FLAG CABIN, STATEROOM, AND BATH
 MODULAR GROUP 5
 GROSS AREA: 500 SQ FT CABIN, 189 SQ FT STATEROOM, 39 SQ FT BATH

Figure 2-8. Typical CO/Flag Living Spaces.

CHAPTER 3 CHIEF PETTY OFFICER (CPO) AND SENIOR NONCOMMISSIONED OFFICER (SNCO) LIVING SPACES

3.1 GENERAL.

3.1.1 Ratings. CPOs and SNCOs are enlisted rates E7 – E9.

- a. Ship's company
- b. Staff (Flag, Group, Squadron, Unit)
- c. Detachments (Air Wing, Helicopter, Marines)
- d. Troops (SNCO)

3.1.2 Number. CPOs typically constitute 6 to 10 percent of total ship's company accommodations. SNCOs typically constitute 3 to 7 percent of total Marine detachment. CPO and SNCO living spaces can vary in number of spaces per ship and number of accommodations per space depending on ship type.

3.1.3 Location.

3.1.3.1 Living Spaces. CPOs and SNCOs shall be berthed separately from other enlisted personnel. Female CPOs shall be berthed separately from their male counterparts. Where practical, CPO living spaces shall be located on the second deck, or above, and adjacent to their messroom and lounge facilities. In surface combatants, divide CPO accommodations fore and aft for better survivability.

3.1.3.2 Types of Living Spaces. As specified in Part I, 2.2.8.2, the types of bunkrooms shall be considered to accommodate any ratio of male and female CPOs or SNCOs.

3.1.3.3 Access. On ships with both males and females, provide privacy partitions or curtains around entrance doors to living spaces that are accessed from passages. Provide direct access between living and associated sanitary spaces.

3.1.4 Functions.

- a. Sleeping
- b. Dressing
- c. Personal stowage
- d. General quarters station for SNCO

3.1.5 Related Spaces.

- a. Sanitary spaces (semi-private T/S, community sanitary space)
- b. Messrooms and lounges
- c. Baggage stowage
- d. Cleaning gear lockers
- e. Passages

3.2 OUTFIT AND FURNISHINGS.

3.2.1 Berth Cubicles. Subdivide living spaces using berths and personal stowage lockers to form cubicles of not more than six persons per cubicle. The cubicle concept maximizes habitability features such as privacy, access to and security for personal belongings, and reduction of noise and light within a minimum amount of area. Ensure that an HVAC supply terminal is installed in the overhead per each six-person cubicle. Lockers shall not be installed within the berth cubicle. Berths shall be two-high with adequate room for a sit-up position or three-high when space availability is an issue. Transient CPOs or SNCOs may be provided with three-high berths.

3.2.1.1 Two-High Berth Cubicles (see Part II, [Figure 3-1](#)).

3.2.1.1.1 Berths. Select locker type berths containing 10 cubic feet of stowage volume under the sleeping surface. Additional features and accessories include:

- a. Built-in curtain/grab bar assembly
- b. Built-in magazine rack and towel bar
- c. Built-in small security locker for valuables
- d. Built-in step for climbing into upper berth
- e. Emergency escape breathing device (EEBD) stowage integral with locker berth
- f. Emergency escape kick-out panel in bottom berth, when required
- g. Individually controlled ventilation fan pulling air into the berth. Provide only where individually controlled HVAC terminal is not provided within the berth during a rearrangement project
- h. Lee strap for retaining occupant in rough weather
- i. Light located at the head end for reading/writing
- j. Mattress: 28 inches wide, 5 inches thick, and 80 or 76 inches long
- k. Privacy curtain in two sections along the accessible side
- l. Privacy partitions on the other three sides except where adjoining a bulkhead, shell, or other structure that provides equivalent privacy
- m. Provision for deck mounting (bottom berth can be made removable where berth is located over a manhole or other access fittings)

3.2.1.1.2 Lockers. Provide a clothing locker for each accommodation. Locker features include:

- a. 6-inch long hanging space
- b. 12-inch short hanging space
- c. 4 cubic feet of stowage volume for CPO
- d. 2.9 cubic feet of drawer volume for SNCO

Where 15 inches or more of usable space is available above the tops of lockers, provide additional built-in stowage.

3.2.1.2 Three-High Berth Cubicles for CPOs and SNCOs and for Transient CPOs and SNCOs (see Part II, [Figure 3-2](#)).

3.2.1.2.1 Berths. Select pan type berths without stowage under the sleeping surface where practicable. All other berth features and accessories are similar to two-high berths, except EEBD stowage and security locker are not integral with the pan berth and sit-up capability is not required.

3.2.1.2.2 Lockers. Provide a clothing locker for each accommodation. Locker features include:

- a. 6-inch long hanging space
- b. 12-inch short hanging space
- c. 14 cubic feet of stowage volume for CPO
- d. 10 cubic feet stowage volume plus 2.9 cubic feet of drawer volume for SNCO

Where 15 inches or more of usable space is available above the tops of lockers, provide additional built-in stowage.

3.2.2 Accessory Furnishings.

- a. Bulletin board
- b. Chairs
- c. Coat hooks
- d. Lavatory
- e. Mirror, full-length
- f. Television support
- g. Trash receptacle
- h. Writing surface

3.3 ARRANGEMENT PRACTICES.

3.3.1 CPO Living Spaces (see Part II, [Figure 3-3](#)).

3.3.1.1 Cubicles. Provide bunkrooms and berthing spaces with cubicles. Ensure that each cubicle contains not more than six persons. Main walkways serving the cubicles shall be not less than 36 inches wide.

3.3.1.2 Berths. Locate berths away from main passages, sanitary spaces, ladders, recreation areas, and other noise sources. Locate heads of berths away from cubicle entrances or as required to best provide distance from sources of noise. Orient berths primarily longitudinally; however, athwartships orientation may be used but shall be limited to not more than 30 percent of the berths where compartment arrangement is improved.

3.3.1.3 Shell. To the extent practical, avoid locating berths and lockers along the shell in order to have better access to shell structure and damage control distributive systems.

3.3.1.4 Installation. Position deck-mounted furniture about 1 inch from bulkheads to ensure adequate clearance for welding. Group like furniture together as much as possible to simplify foundations and minimize deck covering cutouts.

3.3.1.5 Accessories. Mirrors, watch quarter, and station bill panel shall be located outside of cubicles in places where their use does not cause personnel traffic congestion. The full-length mirror shall be located near the primary compartment access.

3.3.1.6 Sanitary Space. Position the access to the sanitary space so that a person entering the living space does not have to traverse a sleeping area to use the head.

3.3.1.7 Fan Coil Assemblies. Where practicable, locate fan coil assemblies outside of living spaces. Where fan coil assemblies must be located within living spaces, position them away from sleeping areas. Ensure that adequate clearance is provided for servicing filters.

3.3.1.8 Accesses. Enclose ladders entering living spaces and those that lead to other spaces above or below the living spaces in order to provide privacy, to reduce noise, and to contain smoke in the event of a fire.

3.3.1.9 Sheathing. Decorative sheathing or carpet is not authorized and shall not be installed.

3.3.2 Command Master Chief Stateroom (see Part II, [Figure 3-3](#)). The Air Wing and Ships Company Command Master Chief are the highest rated CPOs. Provide the Air Wing and Ships Company Command Master Chief with a small single stateroom adjacent to the CPO living space. A lavatory is provided within this stateroom. The Air Wing and Ships Company Command Master Chief stateroom performs traditional stateroom functions, such as an office and conference room. Arrangement practices for small single staterooms (see Part II, 2.3.1) apply to the Air Wing and Ships Company Command Master Chief stateroom.

3.3.3 SNCO Living Spaces (see Part II, [Figure 3-3](#)). Provide SNCOs with living spaces that are separate from CPO living spaces. SNCOs have the same stowage requirements as CPOs except that they have additional stowage for field packs. Location of field pack stowage is dependent upon the ship mission; therefore, field pack stowage should be coordinated with the Marines during the design process. Ensure that furnishings for SNCO spaces are shock-qualified since these spaces are occupied during general quarters. SNCOs are Marines that are riding the ship either in an extended deployment mode or in a point-to-point mode. SNCOs are considered accommodations and are fully supported in terms of sanitary fixtures, food service facilities, provisions, potable water, and all other habitability considerations. Surge SNCOs are unsupported except for a berth.

3.3.3.1 Surge SNCO Living Spaces. Berth surge SNCOs in multi-purpose spaces that can function as recreation spaces or areas for extended deployment SNCOs when surge are not on board. Ensure that these spaces are convertible from one arrangement mode to the other within 48 hours by ship's force. Select berths, recreation tables, and chairs that can alternate between stowed and installed configurations depending on which arrangement mode is in effect. Stowage for alternative mode equipment shall be located in the space and configured to least conflict with whatever mode is in effect. The stowage area shall serve as a common stowage area for equipment not in use. Do not use the cubicle concept for surge. Permanently installed lockers shall be in locations that do not interfere with either arrangement mode. Since surge SNCOs are on board for only short periods of time, they are provided fewer habitability considerations than their extended deployment counterparts. These spaces shall be provided with a conversion diagram showing the arrangement of furniture and equipment in each functional mode, including instructions for installation and stowage. The conversion diagram shall be installed in an unobstructed location within the space. Part II, [Figure 3-4](#) shows an arrangement of a surge troop living space. Similar arrangement practices apply to surge SNCO living spaces.

3.3.4 Command Sergeant Major Stateroom (see Part II, [Figure 3-3](#)). The Command Sergeant Major is the top non-commissioned officer (NCO) of a Marine detachment. Provide the Command Sergeant Major with a small single stateroom adjacent to the enlisted Marine detachment living space. A lavatory is provided within this stateroom. The Command Sergeant Major's stateroom performs traditional stateroom functions, such as an office and conference room. Arrangement practices for small single staterooms apply to the Command Sergeant Major stateroom.

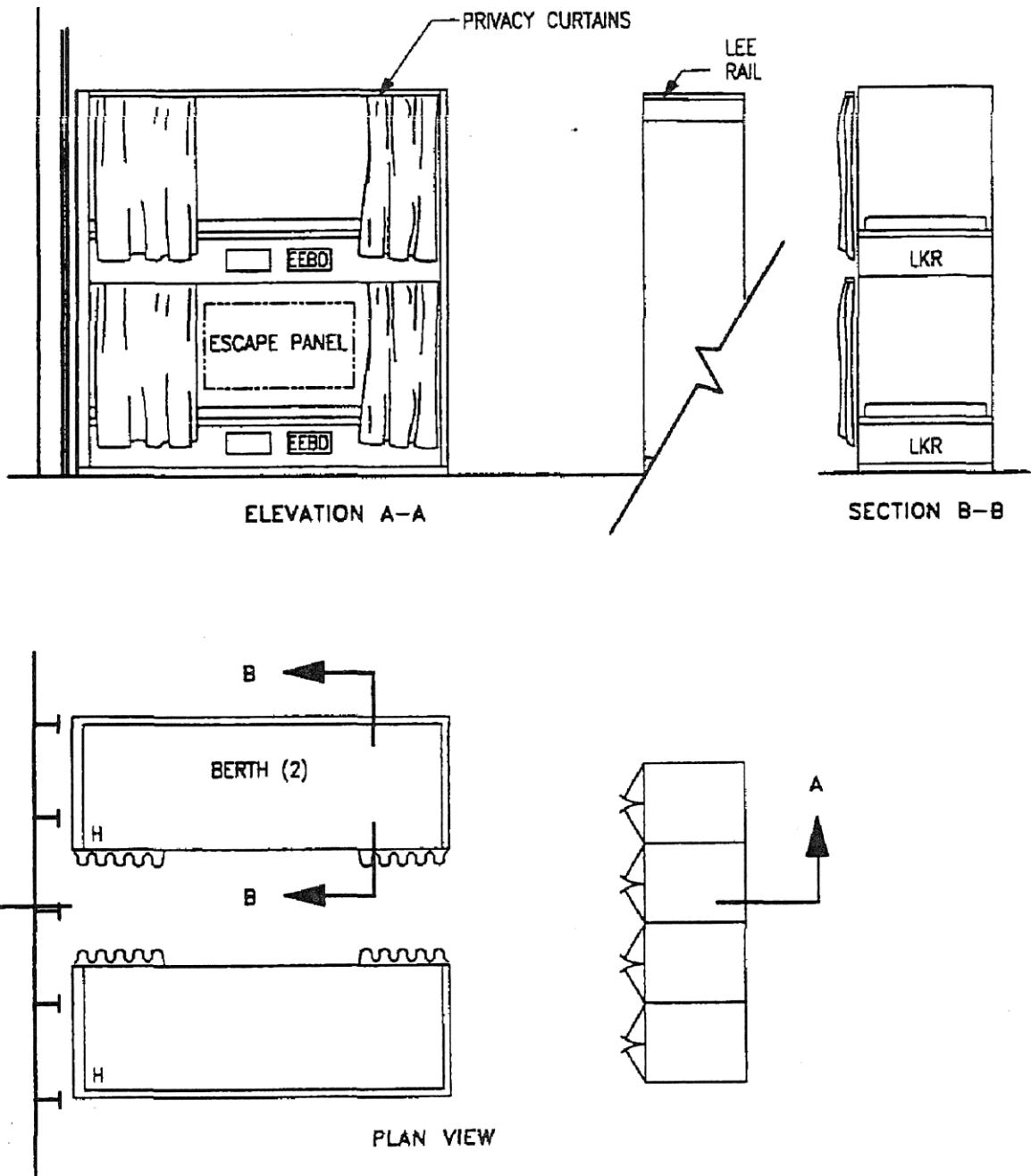

Figure 3-1. CPO Berthing – Two-High Typical Four-Person Cubicle.

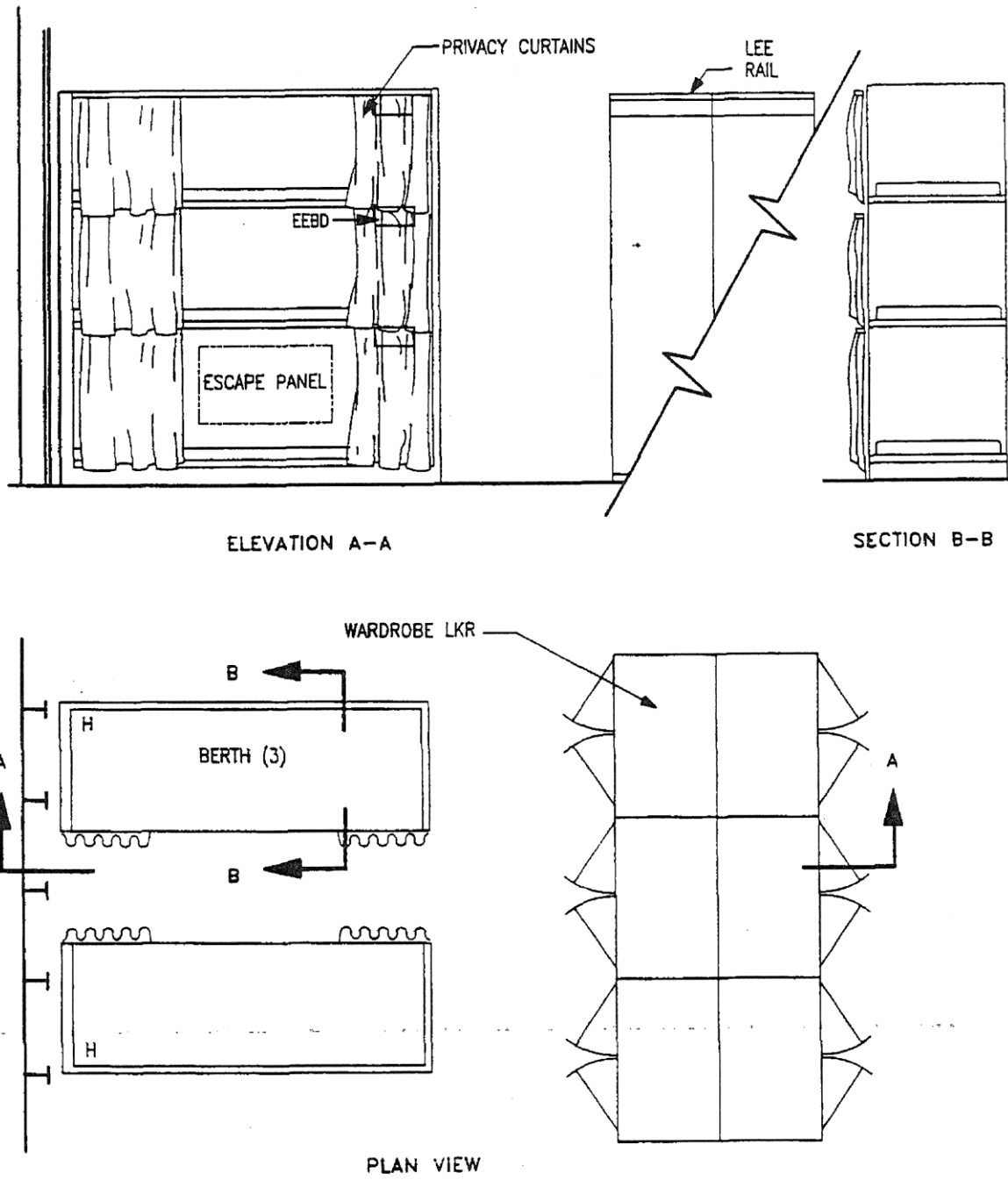
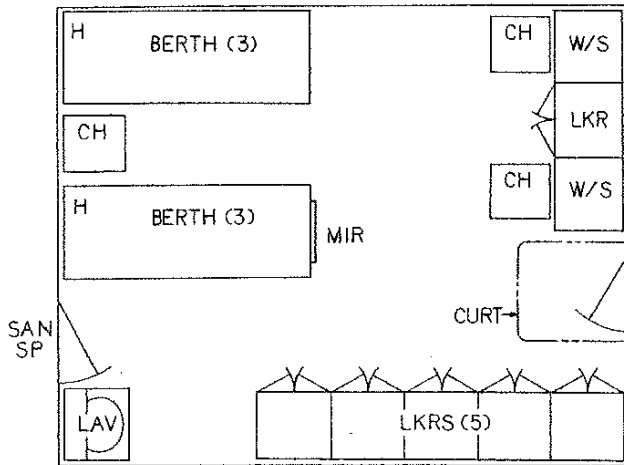
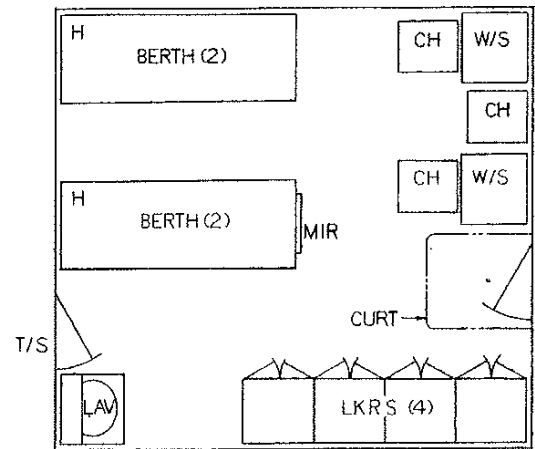

Figure 3-2. CPO or SNCO Berthing – Three-High Typical Six-Person Cubicle.



BUNKROOM - 6 CPO OR SNCO



BUNKROOM - 4 CPO OR SNCO

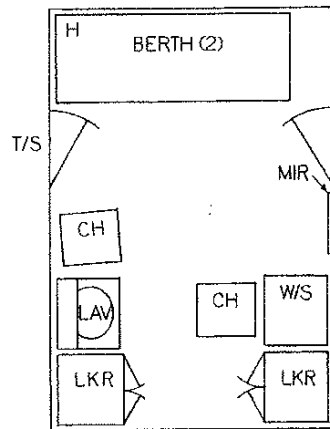

STATEROOM - 2 CPO OR SNCO

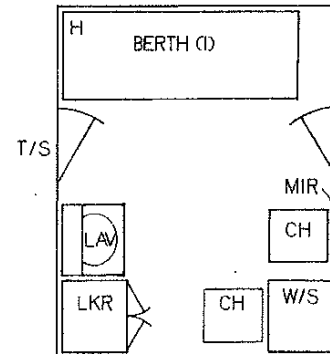

**SINGLE STATEROOM - MASTER
CPO OR SERGENT MAJOR**

Figure 3-3. Typical CPO and SNCO Living Spaces.

CHAPTER 4

CREW AND TROOP LIVING SPACES

4.1 GENERAL.

4.1.1 Ratings. The crew and troops are enlisted rates E1 – E6.

- a. Ship's company
- b. Staff (Flag, Group, Squadron, Unit)
- c. Detachments (Air Wing, Helicopter, Marines)
- d. Troops (SNCO)

4.1.2 Number. The crew typically constitutes 80 to 88 percent of total ship's company accommodations. Troops typically constitute 83 to 91 percent of total Marine detachment. Crew and troop living spaces can vary in number of spaces per ship and number of accommodations per space depending on ship type.

4.1.3 Distribution. Ships prefer to berth crew personnel by division; however, general arrangement constraints usually preclude sizing living spaces to match divisional manning. A reasonable trade-off is to avoid having large-sized spaces and instead provide a mix of small- and mid-sized spaces evenly distributed throughout the ship.

4.1.4 Location.

4.1.4.1 Crew and Troop Living Spaces. Berth crew as high up and near to amidships as practicable. However, due to the large number of crew that must be accommodated, optimum locations for living spaces are not always available. Berth female crew members separately from their male counterparts. In surface combatants, divide crew accommodations fore and aft for better survivability. Locate troop berthing spaces to facilitate access to debarkation points. On ships designated as primary and secondary CRTS, locate troop berthing spaces adjacent to the medical ward to provide for casualty overflow berthing.

4.1.4.2 Types of Living Spaces. As specified in Part I, 2.2.8.1, a combination of living space types shall be considered to accommodate any ratio of enlisted male and female crew or troops.

4.1.4.3 Access. For living spaces with 21 or more personnel, provide additional means of egress in accordance with T9070-AB-PRO-010. Ensure that these accesses are widely separated. On ships with both males and females, provide privacy partitions or curtains around entrance doors to living spaces that are accessed from passages. Provide direct access between living and associated sanitary spaces.

4.1.5 Functions.

- a. Sleeping
- b. Dressing
- c. Personal stowage
- d. General quarters station for troops

4.1.6 Related Spaces.

- a. Lounge/Recreation spaces/areas
- b. Sanitary spaces (community)
- c. Messroom
- d. Baggage stowage
- e. Cleaning gear lockers
- f. Passages

4.2 OUTFIT AND FURNISHINGS.

4.2.1 Berth Cubicles (see Part II, [Figures 4-1 and 4-2](#)). Subdivide living spaces using berths and personal stowage lockers to form cubicles of not more than six persons per cubicle. The cubicle concept maximizes habitability features such as privacy, access to and security for personal belongings, and reduction of noise and light within a minimum amount of area. Ensure that an HVAC supply terminal is installed in the overhead per each six-person cubicle. Avoid installing lockers within the berth cubicle.

4.2.1.1 Berths. The standard berth configuration is typically two-high locker type berths or three-high berths with locker type berths for the two lower sleeping surfaces and a pan type berth for the top. The locker berths each contain 7.5 cubic feet of stowage volume. The pan berth has no stowage and is accompanied by a separate deck-mounted locker having 7.5 cubic feet of stowage volume for troops and 13 cubic feet of stowage volume for crew. Combinations of pan and locker berths other than the standard two- and three-high configuration are permitted to suit constraints in overhead clearance or available deck area. In general, locker berths are preferred for the lower and middle berths in the three-high configuration because they provide more efficient stowage space than deck-mounted lockers. Pan berths are preferred for the top of a three-high berth because a locker berth at this height is difficult to use and the heavy locker top is a potential safety hazard. Additional features and accessories include:

- a. Built-in curtain/grab bar assembly.
- b. Built-in magazine rack and towel bar.
- c. Built-in small security locker for valuables with locker berth.
- d. Built-in step for climbing into upper berth.
- e. EEBD stowage integral with locker berth.
- f. Emergency escape kick-out panel.
- g. Individually controlled ventilation fan for pulling air in to the berth except for upper surge accommodation in four-high berths. Provide only where individually controlled HVAC terminal is not provided within the berth during a rearrangement project.
- h. Lee strap for retaining occupant in rough weather.
- i. Light located at the head end for reading/writing except for upper surge accommodation in four-high berths. See Part I, 2.2.6.a.
- j. Mattress: 26 inches wide, 4 inches thick, and 80 or 76 inches long.
- k. Privacy curtain in two sections along the accessible side.
- l. Privacy partitions on the other three sides except where adjoining a bulkhead, shell, or other structure that provides equivalent privacy.
- m. Provision for deck-mounting (bottom berth can be made removable where berth is located over a manhole or other access fittings).

4.2.1.2 Lockers (for Locker Type Berth). Provide a wardrobe hanging locker with 10 inches short hanging space for each accommodation having a locker type berth. This locker is normally stacked two-high. Provide an additional deck-mounted locker for each accommodation with 5.5 cubic feet of stowage volume for crew only. This locker is normally stacked three-high.

4.2.1.3 Lockers (for Pan Type Berth). Provide a wardrobe locker with 10 inches short hanging space and 7.5 cubic feet of stowage volume for each troop accommodation having a pan type berth. Provide a wardrobe locker with 10 inches short hanging space and 13 cubic feet of stowage volume for each crew accommodation having a pan berth. EEBD stowage is provided in a separate stowage container for pan type berths.

4.2.2 Accessory Furnishings.

- a. Bulletin board
- b. Chairs
- c. Coat hooks
- d. Chin-up bar

- e. Locker, soiled laundry (for crew living spaces, optional for troop living spaces)
- f. Mirror, full-length

4.3 ARRANGEMENT PRACTICES.

4.3.1 Crew Living Spaces (see Part II, Figure 4-2).

4.3.1.1 Cubicles. Provide bunkrooms and berthing spaces with cubicles. See Part I, 2.2.4.3 for alternative requirements on berth cubicles for large deck ships. Ensure that each cubicle contains not more than six persons. Secondary walkways serving the cubicles shall be not less than 30 inches wide. Main walkway width within the berthing area shall be not less than 36 inches. See Part I, 2.2.5.d for additional clearances in berthing areas.

4.3.1.2 Berths. Locate berths away from main passages, sanitary spaces, ladders, recreation areas, and other noise sources. Locate heads of berths away from cubicle entrances or as required to best provide distance from sources of noise. Orient berths primarily longitudinally; however, athwartships orientation may be used but shall be limited to not more than 30 percent of the berths where compartment arrangement is improved. All berths shall be sized to fit an 80-inch long mattress when practicable. Otherwise, 10 percent of berth tiers shall be sized to fit an 80-inch long mattress and the remaining shall accommodate a 76-inch long mattress.

4.3.1.3 Shell. To the extent practical, avoid locating berths and lockers along the shell in order to have better access to shell structure and distributive systems for damage control.

4.3.1.4 Soiled Laundry. The soiled laundry locker is intended to store soiled bed linens, work clothing, and organizational gear prior to processing in the ship's institutional full service laundry. Place the soiled laundry locker next to sanitary spaces to take advantage of the negative air pressure within the head, which will help control odors. Where placement near sanitary spaces is not practical, an exhaust ventilation terminal should be provided above soiled laundry lockers to aid in odor control.

4.3.1.5 Installation. Position deck-mounted furniture about 1 inch from bulkheads to ensure adequate clearance for welding. Group like furniture together as much as possible to simplify foundations and minimize deck covering cutouts.

4.3.1.6 Accessories. Locate mirrors, watch quarter and station bill panels, and bulletin boards outside of cubicles in places where their use does not cause personnel traffic congestion. Locate the full-length mirror(s) near the primary compartment access(es).

4.3.1.7 Sanitary Space. Where the access to the sanitary space is from within the living space, position the access so that a person entering the living space does not have to traverse a sleeping area to use the head.

4.3.1.8 Fan Coil Assemblies. Where practicable, locate fan coil assemblies outside of living spaces. Where fan coil assemblies must be located within living spaces, position them away from sleeping areas. Ensure that adequate clearance is provided for servicing filters.

4.3.1.9 Accesses. Enclose ladders entering living spaces and those that lead to other spaces above or below the living spaces in order to provide privacy, to reduce noise, and to contain smoke in the event of a fire.

4.3.1.10 Sheathing. Decorative sheathing or carpet is not authorized and shall not be used.

4.3.2 Troop Living Spaces (see Part II, Figure 4-3). Provide troops with living and sanitary spaces that are separate from crew living spaces. Arrangement practices noted in Part II, 4.3.1 also apply to troop living spaces. Troops have different stowage requirements than crew and receive different outfit and furnishings, including stowage for field packs and rifles. Location of field pack and rifle stowage is dependent upon the ship mission; therefore, it should be coordinated with the Marines during the design process. Ensure that furnishings for troop spaces are shock-qualified since these spaces are occupied during general quarters. Troops are Marines that are riding the ship either in an extended deployment mode or in a point-to-point mode. Troops are considered accommodations and are fully supported in terms of sanitary fixtures, food service facilities, provisions, potable water, and all other habitability considerations. Surge troops are unsupported except for a berth.

4.3.2.1 Surge Troop Living Spaces (see Part II, Figure 4-4). Berth surge troops in multi-purpose spaces that function as recreation spaces or areas for extended deployment troops when surge are not on board. Ensure that these spaces are convertible from one arrangement mode to the other within 48 hours by ship's force. Select berths, normally four-high, recreation tables, and chairs that can alternate between stowed and installed configurations depending on which arrangement mode is in effect. Stowage for alternative mode equipment shall be located in the space and configured to least conflict with whatever mode is in effect. The stowage area shall serve as a common stowage area for equipment not in use. Do not use the cubicle concept for surge. Permanently installed lockers shall be in locations that do not interfere with either arrangement mode. Since surge troops are on board for only short periods of time, they are provided fewer habitability considerations than their extended deployment counterparts. These spaces shall be provided with a conversion diagram showing the arrangement of furniture and equipment in each functional mode, including instructions for installation and stowage. The conversion diagram shall be installed in an unobstructed location within the space.

4.3.2.2 Surge Troop Living Spaces in Ships With High Deck Heights. Berth surge troops in troop living spaces above the uppermost berth of three-high berth tiers. The surge berth is not provided with privacy curtains or light.

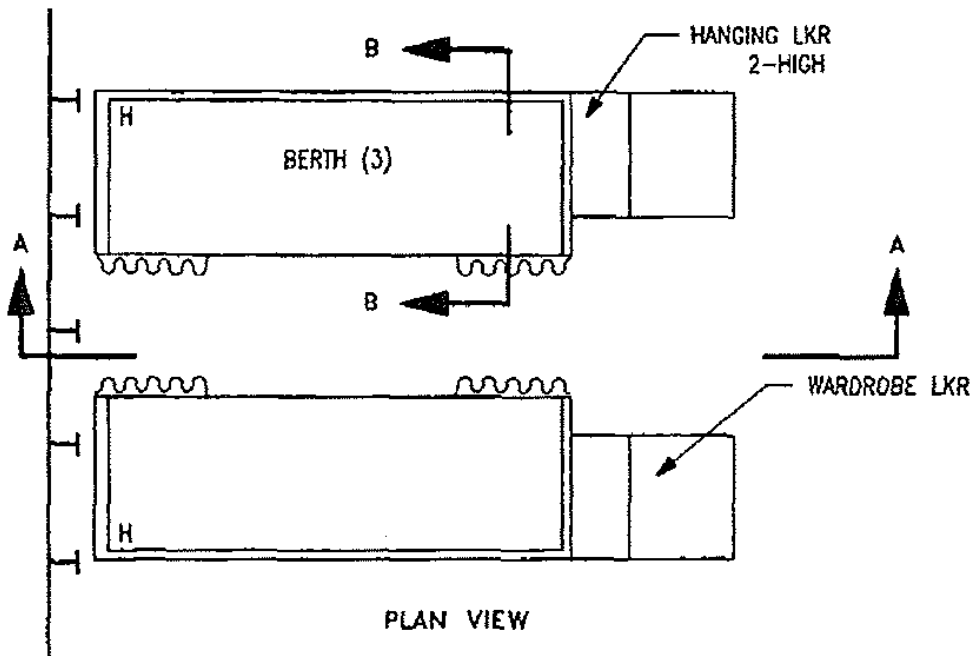
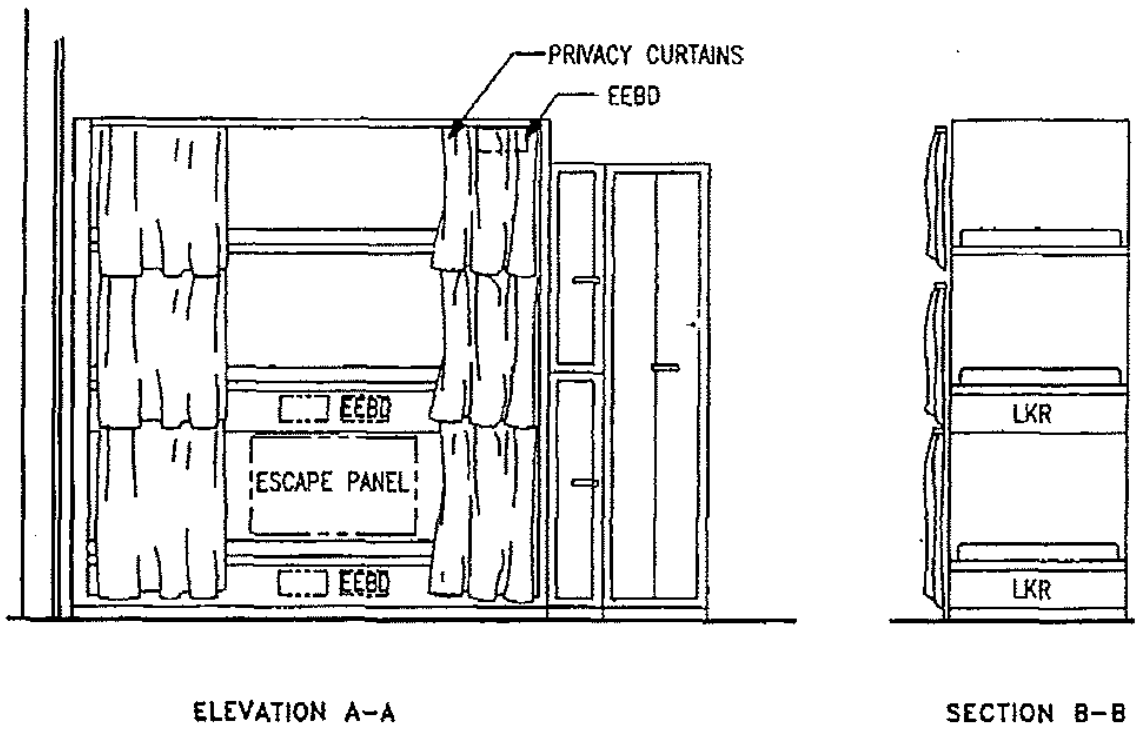

Figure 4-1. Enlisted Crew or Troop Berthing – Three-High Typical Six-Person Cubicle.

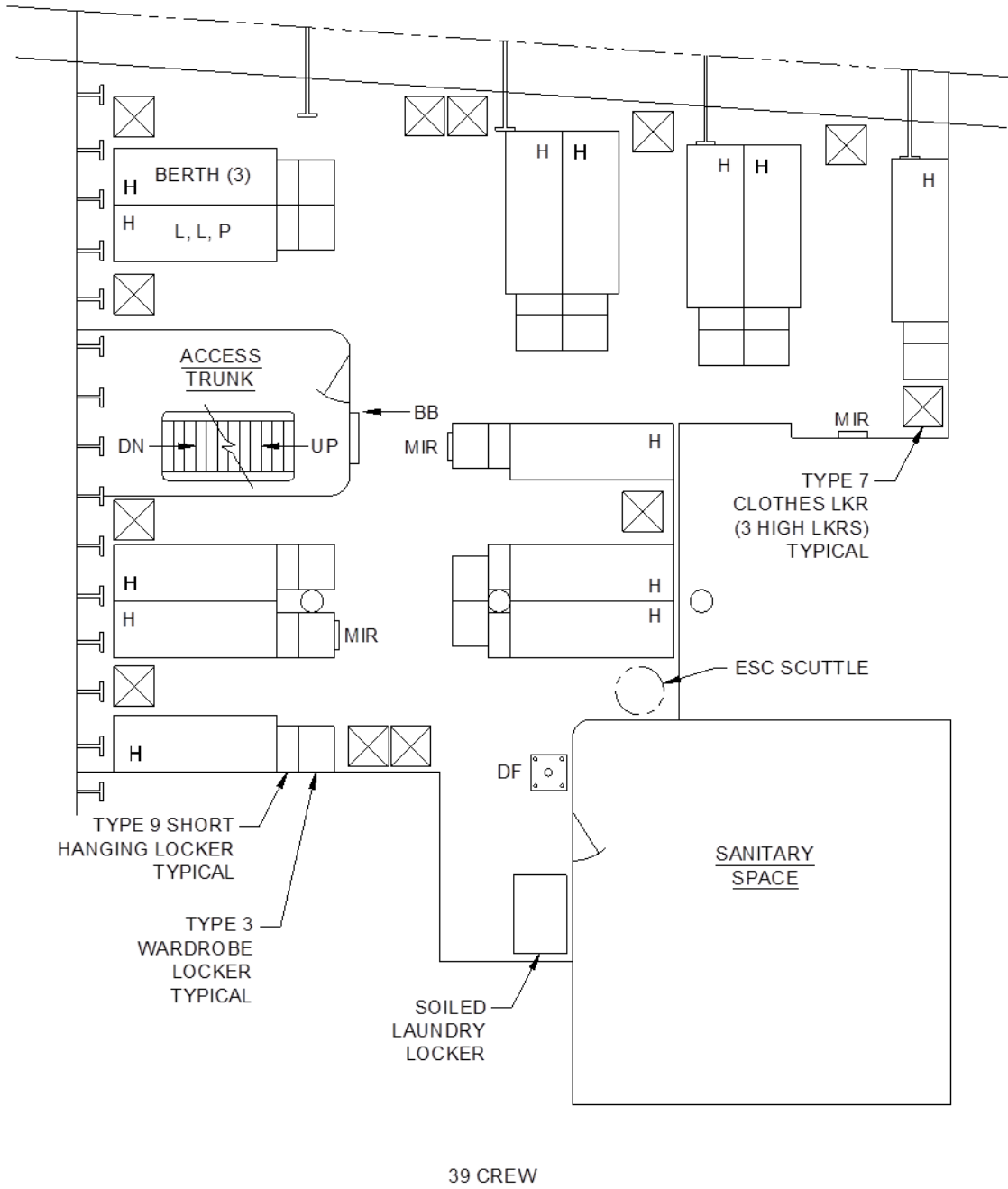
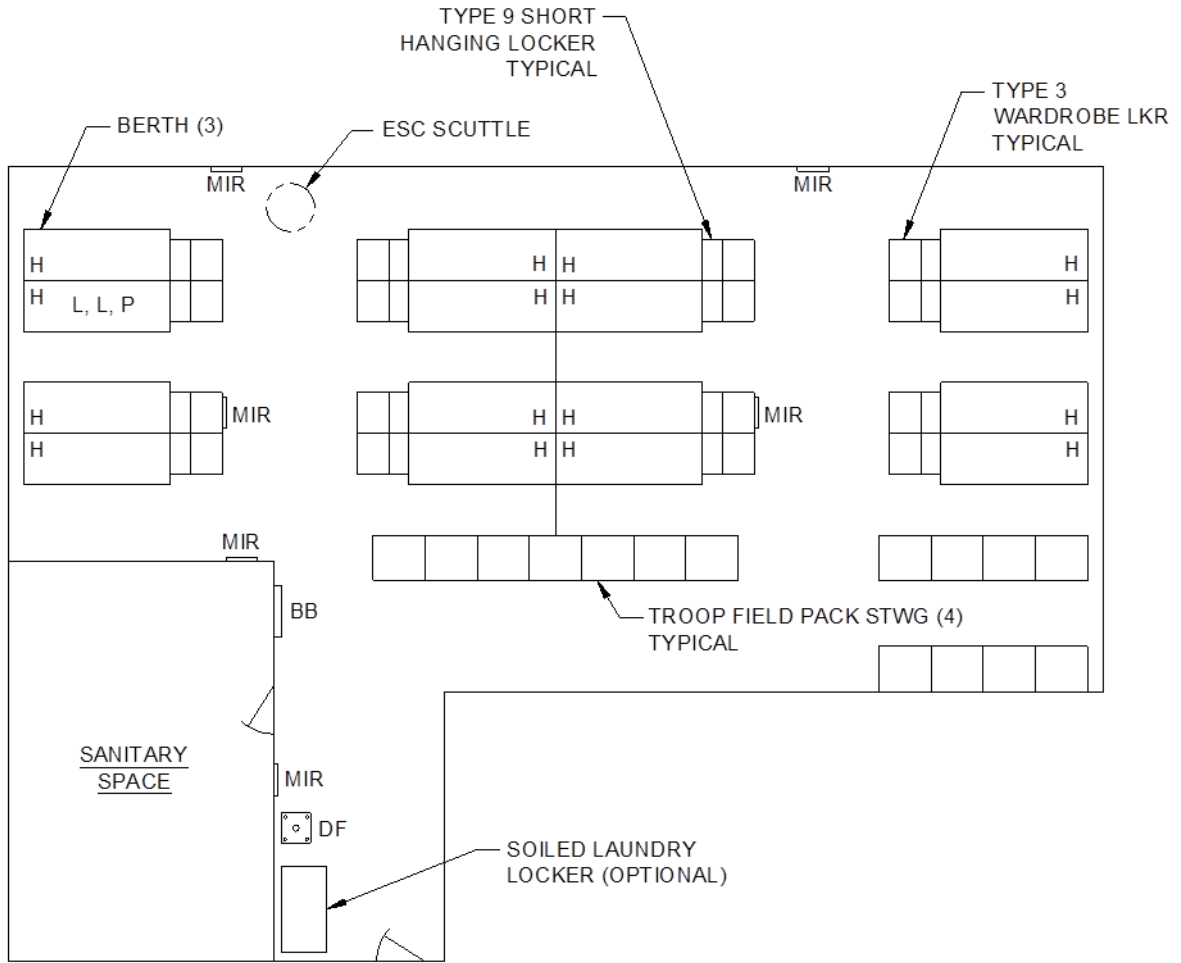

Figure 4-2. Typical Crew Living Space.



48 EXTENDED DEPLOYMENT TROOPS

Figure 4-3. Typical Troop Living Space.

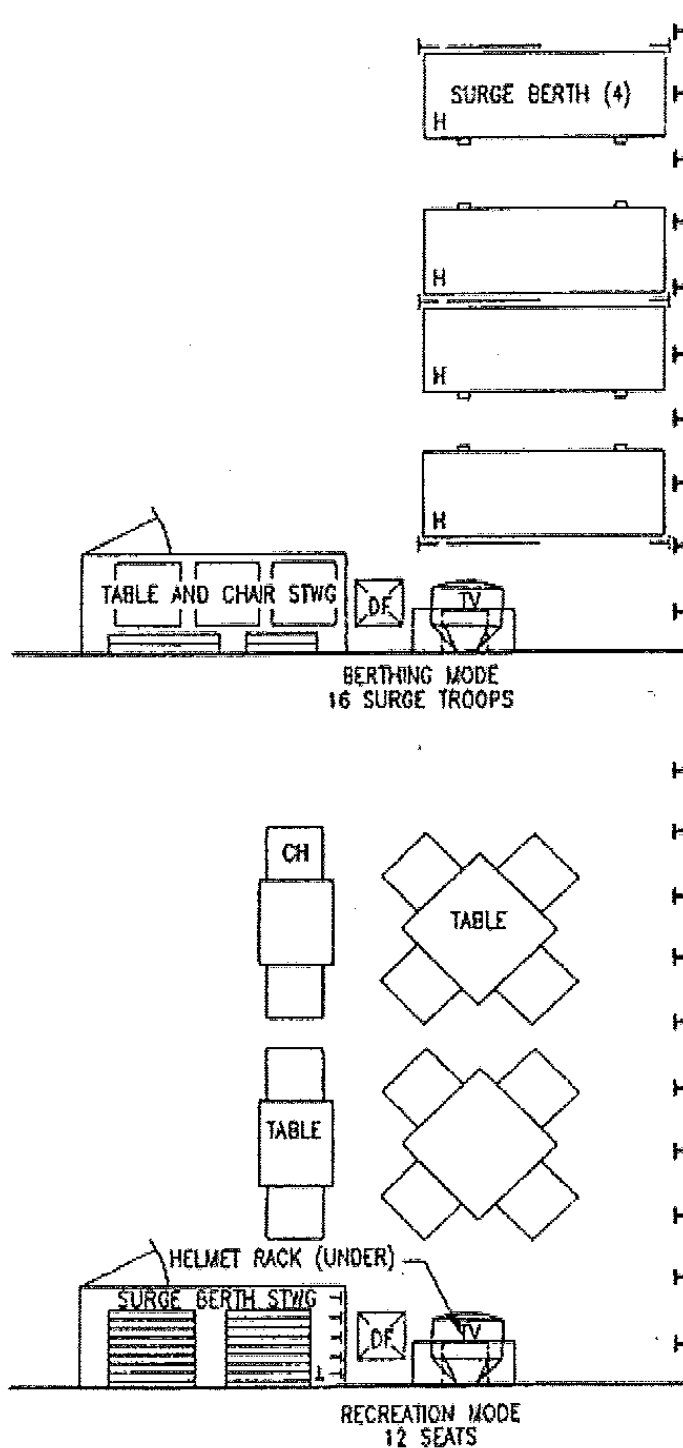

Figure 4-4. Typical Multi-Purpose Area Troop Recreation/Surge Berthing.

CHAPTER 5 SANITARY SPACES

5.1 GENERAL.

Sanitary spaces are also commonly referred to as heads.

5.1.1 Distribution.

- a. Provide officers, CPO, and crew with separate sanitary spaces within their respective living areas.
- b. Provide female personnel with sanitary spaces that are separate from those of their male counterparts.
- c. Provide troop enlisted personnel with sanitary spaces that are separate from those of ship's company.
- d. Provide additional facilities that are used by all personnel near work spaces.

5.1.2 Types.

- a. Community facilities:
 - (1) WR, WC, and SH
 - (2) Deck WR/WC
 - (3) Ward WR, WC, and SH
- b. Private and semi-private facilities:
 - (1) Bath
 - (2) Private T/S
 - (3) Semi-private T/S
 - (4) Quiet room bath

5.2 OUTFIT AND FURNISHINGS.

Provide and outfit sanitary spaces in accordance with 804-6983514. Figures are provided showing plan and elevation views of major fixtures. WCs and showers are individual type units, although they may share common privacy partitions. Lavatories may be individual units or multiple units set in continuous countertops.

5.2.1 Water Closet (WC or Toilet, see Part II, [Figure 5-1](#)).

5.2.1.1 Design. Install vitreous china WCs (except in brigs, where CRES shall be used). Vitreous china, as compared to other materials, is durable, easily cleaned, and aesthetically superior and has seen satisfactory use in Navy ships since the 1950s. Provide shock mounts with vitreous china WCs to avoid fractures caused by ship structural vibration and deflection. Vitreous china is the preferred material for WCs; however, CRES WCs may be installed as an option.

5.2.1.2 Piping. Supply freshwater for flushing water and install an individual flushometer and a cutout valve upstream of each flushometer to allow WCs to be secured individually for maintenance or repair. WCs shall drain to the Marine Sanitation Device (MSD), which may be gravity- or vacuum-collected.

5.2.1.3 Orientation. If a gravity drain system is used, WCs shall face forward or aft to minimize the siphoning effect on traps due to ship roll.

5.2.1.4 Partitions. In community and semi-private sanitary spaces serving more than two persons, enclose each WC with partitions for privacy. A standard enclosure is 30 inches wide and provides 30 inches of knee room in front of the WC. Ensure partitions are corrosion resistant and smooth sided for durability and easy cleaning. Partitions should be entirely supported from the overhead and bulkheads to simplify deck maintenance.

5.2.1.5 WC Door. For a standard enclosure, provide a single door opening inward. Locate the door at the end or side of the enclosure, as shown on Part II, [Figure 5-1](#), and provide a spring loaded hinge set to hold it open except when latched from inside. Provide a coat hook on the inside of the door centered near the top. Where a standard enclosure cannot be provided, a double door may be installed.

5.2.1.6 Accessories.

- a. Toilet paper holder
- b. Toilet seat
- c. Sanitary napkin receptacle (deck WR/WC)
- d. Sanitary napkin disposal container (removable when not needed in sanitary spaces serving living spaces when inhabited by males)

5.2.2 Shower (see Part II, Figure 5-2).

5.2.2.1 Piping. Supply hot and cold fresh water from the potable water system to a manually operated mixing valve and drain waste water to the MSD system. Add a cutout valve upstream of each mixing valve to allow showers to be secured individually for maintenance or repair.

5.2.2.2 Orientation. Where practicable, avoid installing shower heads on the bulkhead or partition opposite the shower curtain.

5.2.2.3 Partitions. Install CRES joiner bulkheads and CRES partitions to form individual shower stalls. Stalls in community sanitary facilities open to a common shower drying area. Stalls in private and semi-private sanitary spaces open to the compartment. CRES partitions in showers may be constructed of sheet metal in lieu of the honeycomb partitions shown in 804-6983514.

5.2.2.4 Accessories.

- a. Curtain
- b. Curtain rod
- c. Grab rod
- d. Soap and shampoo shelf
- e. Towel hook or rack
- f. Footrest

5.2.2.5 Combination Shower and Decontamination Station. When a shower is also designated for use as a decontamination station, this space shall be in accordance with S9086-QH-STM-010/470.

5.2.3 Lavatory (see Part II, Figure 5-3).

5.2.3.1 Design. Two lavatory designs are used, a vanity type lavatory for private sanitary spaces and officer staterooms and a countertop lavatory for community sanitary spaces. The vanity type lavatory is a single-bowl unit. The countertop lavatory may have one or more bowls depending on the number of persons served. Both lavatories feature CRES bowls, mirrors, fluorescent lighting fixtures, and auxiliary electrical outlets. The vanity type lavatory also features a built-in cabinet behind the mirror and another below the bowl. The countertop lavatory has a continuous countertop and full-width mirror to serve as many persons as possible during peak periods.

5.2.3.2 Piping. Supply hot and cold fresh water from the potable water system to the faucet and drain waste water to the MSD system. Add a cutout valve upstream of each lavatory faucet to allow lavatories to be secured individually for maintenance or repair. Piping to a countertop lavatory is exposed below the countertop for easy access and maintenance.

5.2.3.3 Orientation. Face lavatories forward or aft, where practicable, to enable personnel to better brace themselves and to reduce water slosh towards users as the ship rolls. Other orientations may be used where overall compartment arrangement is improved.

5.2.3.4 Accessories.

- a. Electric hand dryer (optional)
- b. Paper towel dispenser
- c. Soap dispenser
- d. Towel hook or rack
- e. Trash receptacle
- f. Tumbler and toothbrush holder (private bath only)

5.3 ARRANGEMENT PRACTICES.

5.3.1 WR, WC, and SH Facilities (see Part II, Figure 5-4). The goal is to efficiently use available space, provide privacy, control heat, humidity, and odors, and ensure the sanitary space can be easily cleaned and maintained. The number of fixtures and accessories required is based on the number and type of accommodations locally served by the sanitary space. Approximate areas in square feet per person are as follows:

- a. Officer – 12 square feet
- b. CPO – 8 square feet
- c. Crew – 4 square feet

5.3.1.1 Sanitary Space Grouping. In living areas with multiple sanitary spaces, group them together horizontally and align them vertically to simplify piping runs and collection of wastes. Where sanitary spaces are vertically stacked, align like fixtures where practicable.

5.3.1.2 Functional Area Grouping. Within individual community sanitary spaces, group like fixtures together into functional areas (i.e., WC area). This will help to minimize support system requirements such as piping and ventilation runs.

5.3.1.3 Access and Arrangement. Provide access to community sanitary spaces directly from the living spaces served. Personnel shall not have to cross main passages or transit decks to reach their assigned sanitary space. On large deck ships, if staterooms or bunkrooms are served by a community sanitary space, access to this space shall be from a secondary passage (preferably a dead-end passage to provide a measure of privacy). Position lavatories, the most frequently used fixtures, close to the access of a space; position WCs and showers farthest from the access. Ensure that access to washing facilities avoid the need to pass through a WC area.

5.3.1.4 Clearances, Spacing, and Orientation. See Part II, [Figure 5-4](#) for fixture spacing and orientation guidelines.

5.3.1.5 Bulkhead Separation. Where more than four WCs are required, separate the WR and WC areas by bulkheads to ensure better control of odors. Provide at least one lavatory within each WC area.

5.3.1.6 Cleaning and Maintenance. Sanitary spaces must be secured part time each day for cleaning and at irregular intervals for maintenance.

5.3.1.7 Shower Partitions and Bulkheads. In community sanitary spaces, with CRES partitions and bulkheads, provide a separate shower compartment consisting of an individual shower stall opening to a common shower drying area. Where space and weight permit, provide an individual shower drying area for each shower stall. Use partitions between adjacent stalls and between stalls and drying area. Use bulkheads around the outer periphery of the stalls and drying area to keep shower heat and humidity from the rest of the sanitary space.

5.3.1.8 Shower Drying Area Door. In community sanitary spaces, provide a door at the access to the shower drying area to assist in controlling heat and humidity. Select door swing that will minimize interference with personnel traffic. Provide a ventilation opening at the bottom of the door to supply air to the shower.

5.3.1.9 Shell/Weather Bulkhead Constraint. Avoid locating showers adjacent to the shell or a weather bulkhead since the high humidity in showers will damage the thermal insulation and lead to excess sweating and potential corrosion problems.

5.3.1.10 **Cleaning Gear Locker.** Provide a built-in cleaning gear locker with bucket fill station or service sink in the washroom area of a sanitary space with more than three lavatories. Within the locker, install a swab and broom rack, soap dispenser, and paper towel dispenser. Supply hot and cold fresh water to the bucket fill station or service sink. In smaller sanitary spaces, install hot and cold bib type, self-closing faucets for filling buckets at a convenient location within the washroom area, approximately 24 inches above the deck. See Part I, 2.4.8.c for cleaning gear lockers supporting T/S spaces, deck WR/WC spaces, and other spaces.

5.3.1.11 **Water Heaters.** Avoid locating water heaters within sanitary spaces to preclude additional heat and humidity being transmitted to the compartments. Water heaters shall be installed in vented and insulated compartments. Indicate water heater location on the arrangement drawing to avoid design encroachment later.

5.3.1.12 **Towel Hooks and Racks.** Distribute towel hooks or racks evenly along shower drying area bulkheads and mount them high enough to preclude a safety hazard should a person fall against the bulkhead.

5.3.1.13 **Ventilation.** Provide mechanical exhaust ventilation over WC areas to remove odors and over shower areas to remove heat and humidity. Install grilles in bulkheads separating sanitary spaces from berthing spaces or passages for natural supply ventilation. Locate grilles to suit HVAC system design.

5.3.1.14 **Heating.** Provide bulkhead-mounted convection heaters within sanitary spaces since natural supply ventilation requires supplemental heating.

5.3.1.15 **Deck Covering, Coamings, and Drains.** Sanitary spaces are considered wet spaces. Deck coverings in sanitary spaces must be flexible, durable, easily cleaned and maintained, have good slip resistance, and be aesthetically pleasing. Install deck drains within sanitary spaces and ensure deck covering is sloped towards the drains. Provide bulkheads surrounding sanitary spaces with a 12-inch CRES coaming and provide doors to sanitary spaces with a 6-inch sill. For sanitary spaces, deck coverings shall be selected in accordance with NAVSEA Standard Item 009-26.

5.3.2 **Deck WR/WC (see Part II, [Figure 5-5](#)).** Deck WR/WC is a generic name for a sanitary space accessed from a passage and serving nearby spaces. It shall serve either male or female personnel. Provide a minimum of one WC and one countertop lavatory unit in each deck WR/WC space.

5.3.3 **Ward WR, WC, and SH.** This facility serves the medical ward and is outfitted as a WR, WC, and SH. Access is directly from the ward. The number of fixtures is determined by the number of berths in the ward.

5.3.4 **Bath (see Part II, [Figure 5-6](#)).** Provide baths for senior officers whose staterooms have adjoining cabins. Locate access to the bath from the stateroom. Also, in cases where there is no adjoining cabin, provide a private bath for the CO in all ships, and for the XO in destroyer size and larger ships. An alternate arrangement to the one shown on Part II, [Figure 5-6](#) locates the three major fixtures side-by-side. Privacy partitions are not required for the WC, nor is a shower drying area necessary, since the bath is used by only one person at a time.

5.3.5 **Private T/S.** Private T/S shall be provided to serve an adjacent stateroom where a bath is not required and will typically serve two people. A private T/S shall contain a curtained shower and WC without a privacy door. A lavatory is provided in each stateroom.

5.3.6 **Semi-Private T/S (see Part II, [Figure 5-7](#)).** Semi-private T/S shall be provided to serve a bunkroom or between two adjacent staterooms and will typically serve two to six people. It shall contain a WC with a privacy door and a curtained shower with a vestibule in between. A lavatory is provided in each stateroom or bunkroom.

5.3.7 **Quiet Room Bath.** The quiet room bath serves the quiet room in the medical complex. Outfit and arrange similar to a private bath, except provide bed pan cleaning unit and hamper. A patient call system shall also be installed.

5.3.8 **Brig.** Fixtures for brigs shall meet special requirements to ensure protection of prisoners and guards. Provide and arrange brig sanitary fixtures in accordance with 804-5959213.

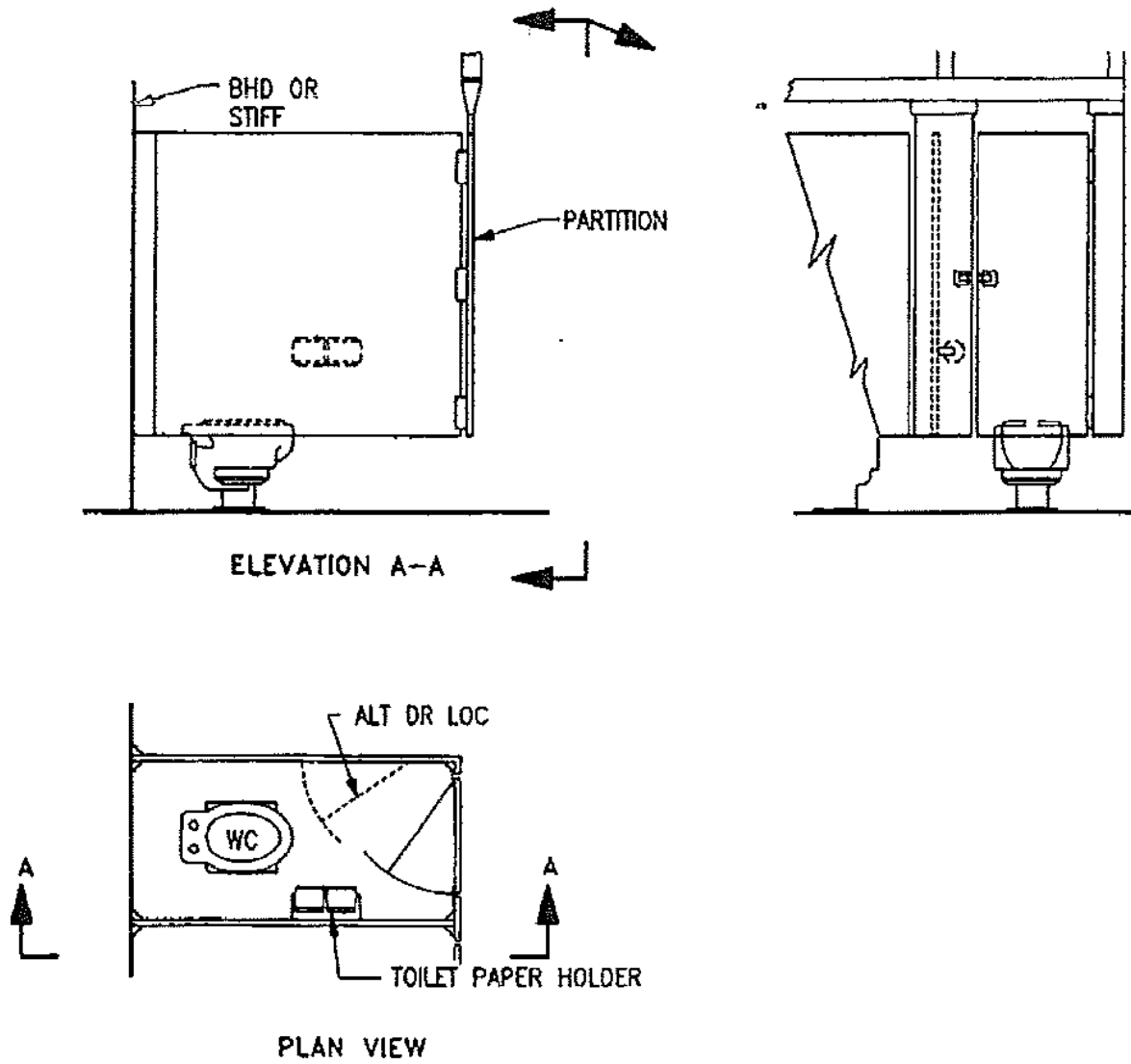

Figure 5-1. Water Closet and Partition.

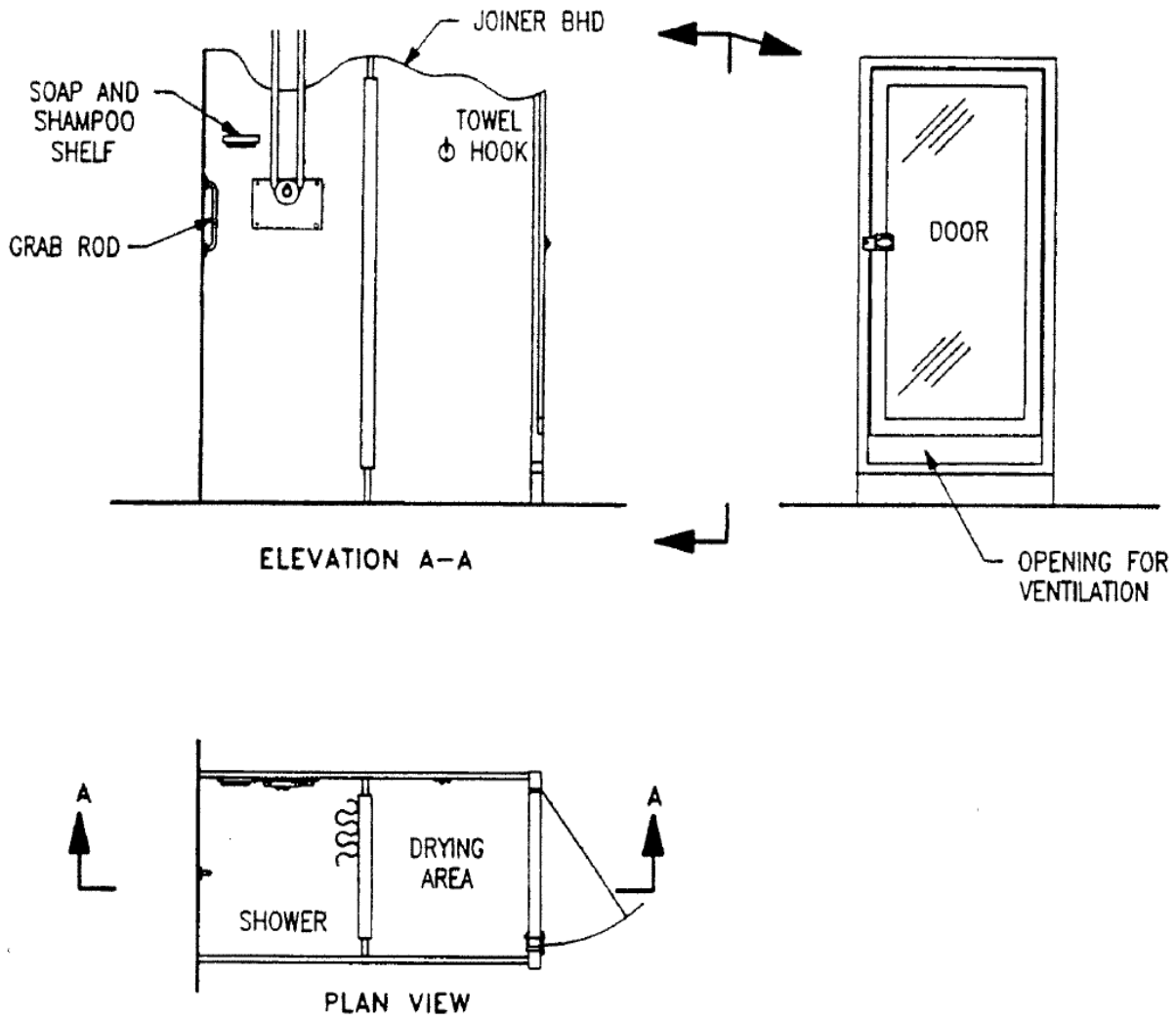

Figure 5-2. Shower and Partition.

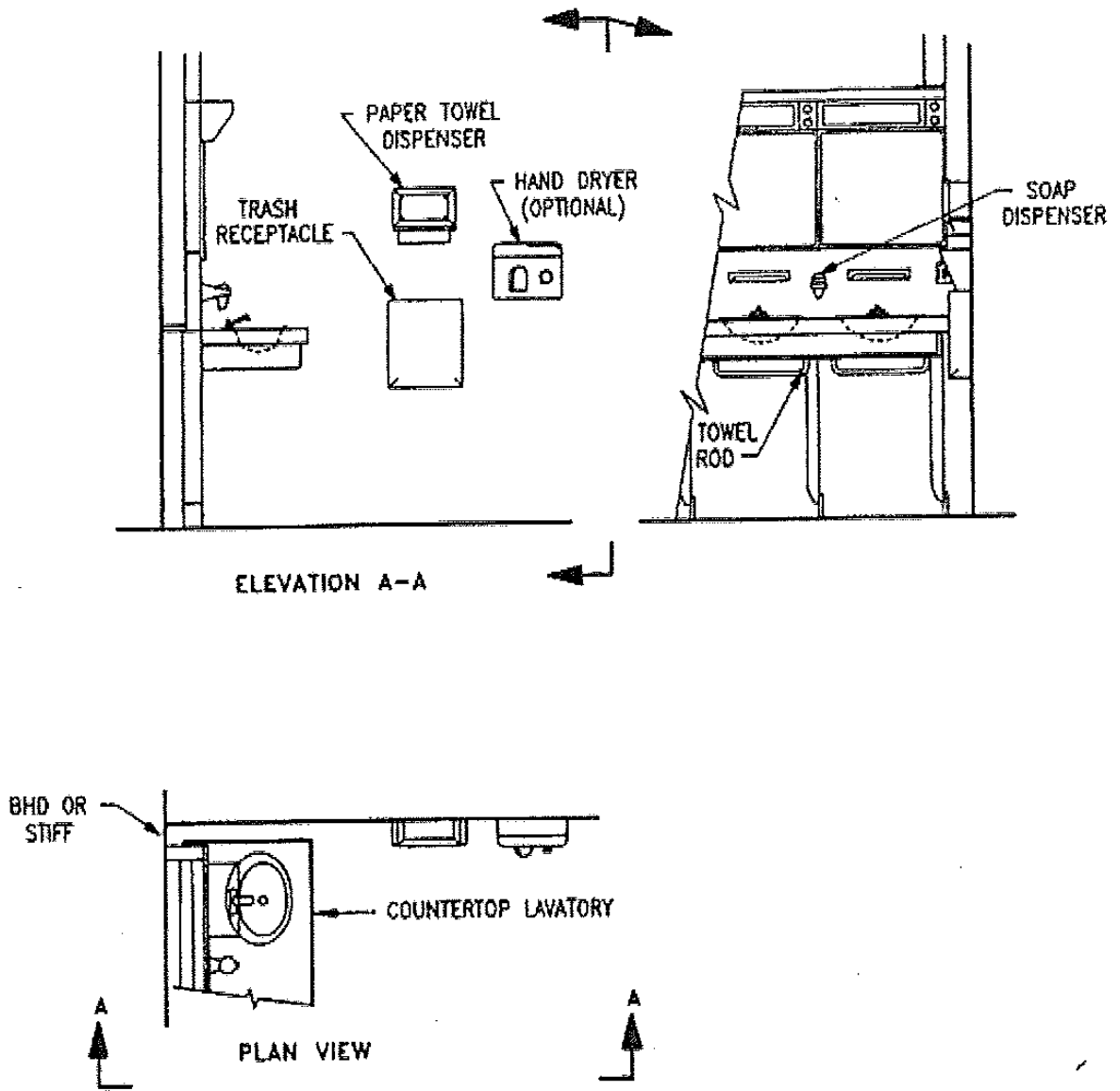

Figure 5-3. Countertop Lavatory.

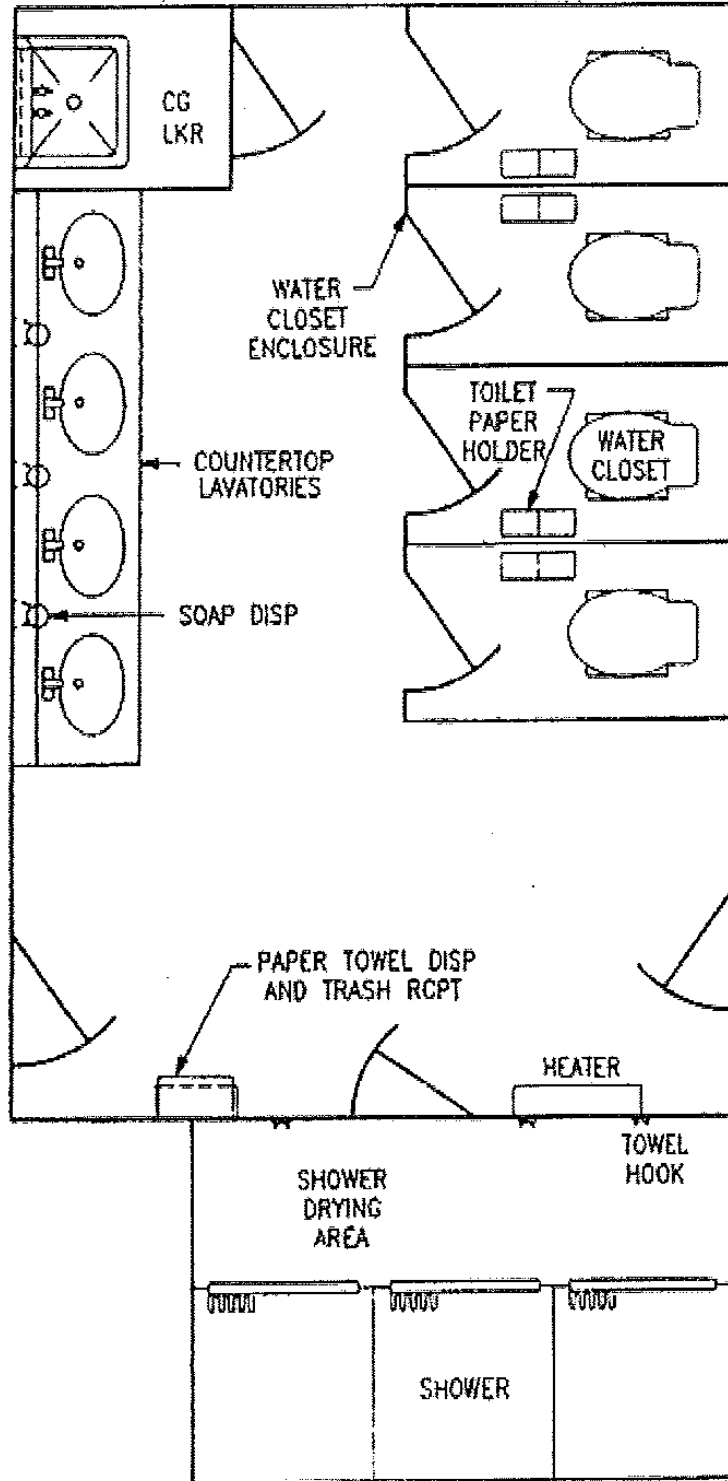

Figure 5-4. Typical Community Sanitary Space.

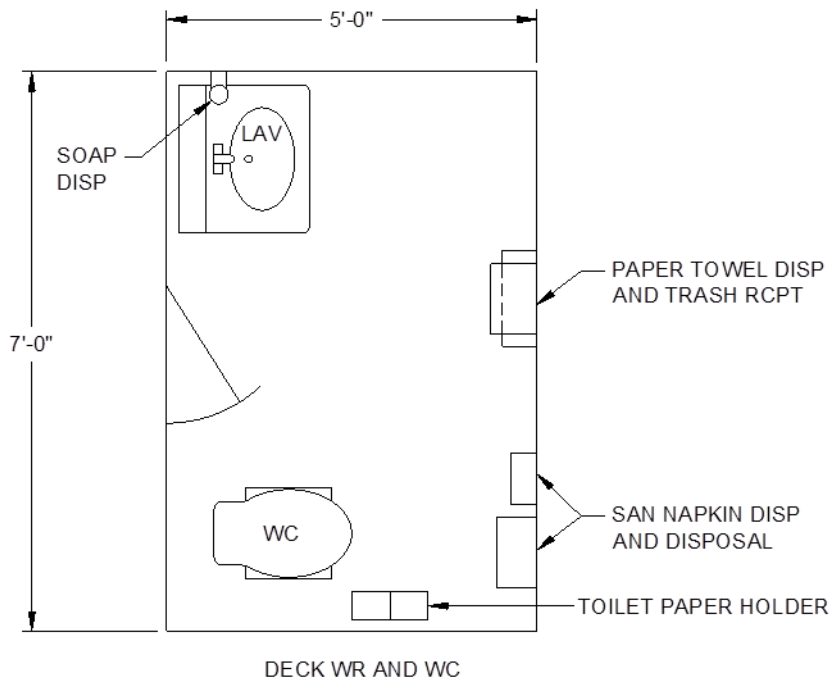

Figure 5-5. Typical Deck WR/WC.

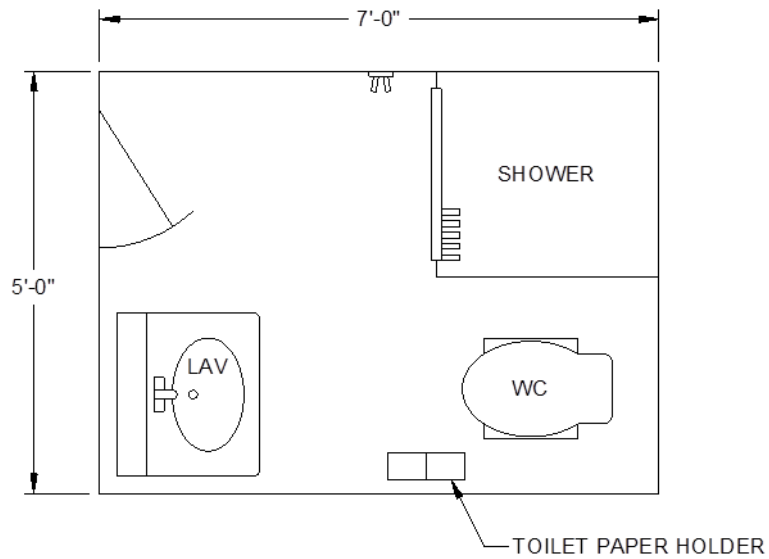

Figure 5-6. Typical Bath.

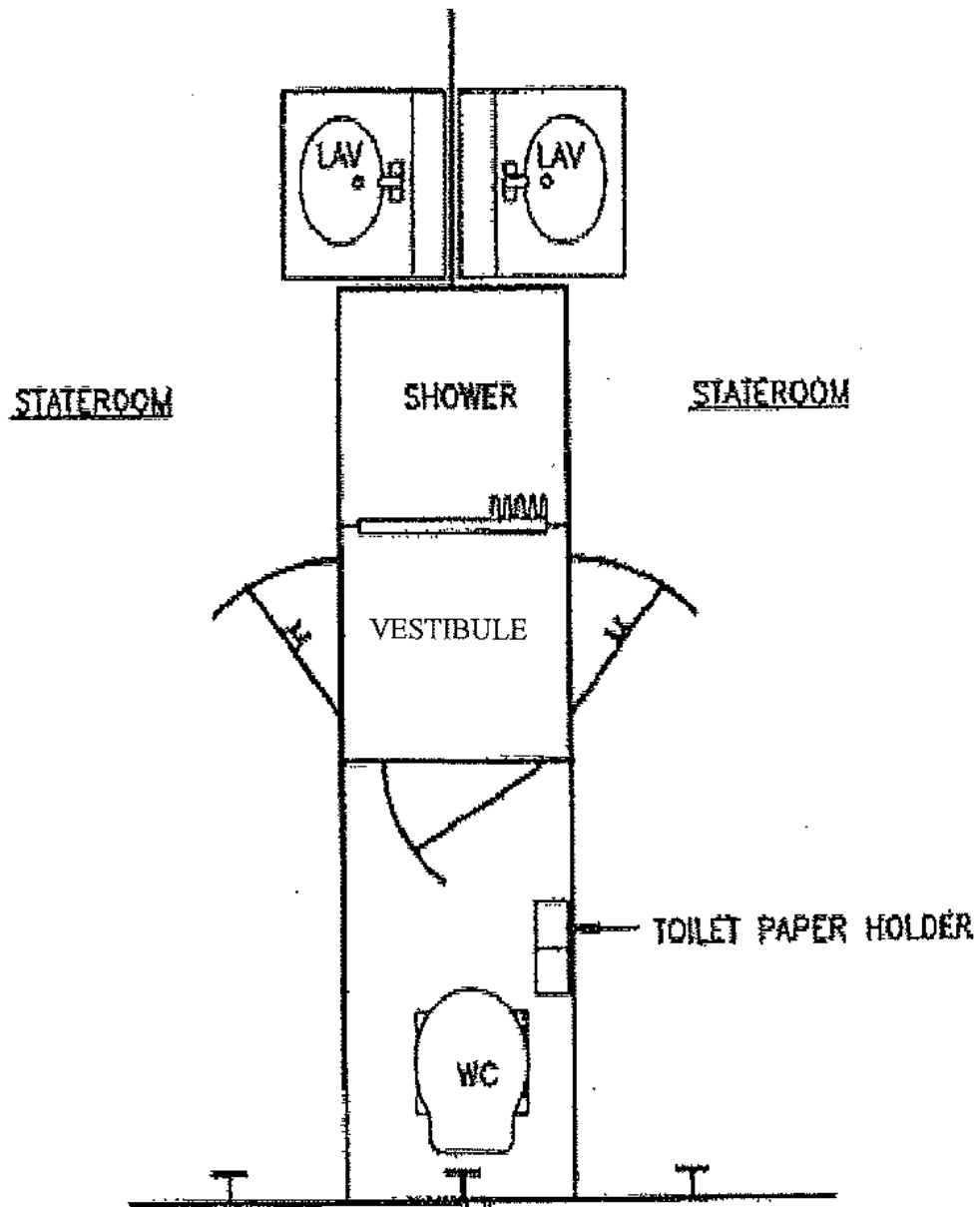

Figure 5-7. Semi-Private T/S.

CHAPTER 6 LEISURE AND COMMUNITY SPACES

6.1 GENERAL.

Leisure and community spaces include the chapel, LMRC, physical fitness, lounge, recreation, and training spaces. The space configurations, types, quantities, and arrangement of equipment in some leisure and community spaces are under the cognizance of the following organizations:

- a. Chapel – Chief of Chaplains
- b. LMRC – Chief of Chaplains
- c. Physical fitness – Bureau of Personnel (BUPERS)

NAVSEA is responsible for other leisure and community spaces. Standards for leisure and community spaces apply to a peacetime Navy. In wartime, these spaces may be converted for use as additional berthing, storerooms, or other purposes.

6.1.1 Purpose. To provide a change from watchstanding and working routine. A well-balanced program of shipboard and ashore recreational activities is provided, which promotes re-enlistment. These activities can be effective in maintaining crew morale and in fighting drug and alcohol abuse. The goal is to provide space for one third of the crew to participate simultaneously in some form of leisure or community activity.

6.1.2 Types. Provide a mix of leisure and community spaces, including areas for quiet, passive pursuits and personal entertainment, recreational areas for active social and competitive events, and an area for spiritual welfare.

- a. Spaces for use by all personnel:
 - (1) Chapel
 - (2) LMRC
 - (3) Physical fitness room
 - (4) Training and recreation room
- b. Spaces provided for each personnel group:
 - (1) Lounge (officer, CPO, crew)
 - (2) Recreation space (crew only)

6.2 CHAPEL.

6.2.1 Function. Provides a place for special services, personal devotion, and group Bible study. It is the location for regular weekly services. Large spaces, such as the hangar bay on aircraft carriers, are used for special services when a large number of personnel participate.

6.2.2 Outfit and Furnishings. Provide altar, digital programmable organ/piano, chairs, arm chair for chaplain, pulpit, television, support, and liturgical decoration. All chapel furnishings shall be portable to permit convertibility to alternate functions. Provide a storeroom with access directly into the chapel for stowage of furnishings when chapel is used for alternate functions. A religious literature locker shall be provided in the passage adjacent to the chapel.

6.2.3 Arrangement Practices (see Part II, Figure 6-1). A chapel is provided for ships with more than 1,000 accommodations with a minimum of 30 seats and for aircraft carriers with a minimum of 45 seats. A secondary egress is required since the space holds more than 20 persons. Provide lockable storeroom, within the vicinity of, or directly accessible from within, the chapel, with drawer, locker, and jack rod stowage aids for stowing all gear. Install a service sink and small commercial off-the-shelf washer and dryer in the storeroom for the cleaning and maintenance of religious elements and altar gear. Mount a movie screen in the overhead where it may be pulled down and used to show films. Install bulkhead and overhead sheathing and carpeting throughout. Provide incandescent lighting in the chapel with a separate circuit for the chancel area and spot lights for the altar and lectern. Provide power for the eternal light installed adjacent to the tabernacle.

6.2.3.1 Fully Mobile Arrangement. Altar, lectern, and all seats are mobile. Locate altar and lectern for optimal viewing by all persons. When provided, locate organ/piano so that operator can view the speaker.

6.2.3.2 Fixed Chancel Arrangement. Altar and lectern are permanently mounted in a dedicated chancel area; seating remains portable. Other arrangement practices are similar to the fully mobile design.

6.3 LMRC.

6.3.1 Function. Provides a place for recreational reading and self-study for improving job performance and for advancement in rank.

6.3.2 Outfit and Furnishings. Provide customer service counter, librarian workstation, library shelving, magazine rack, paperback book rack, chairs, and built-in book return. Provide tables for recreational reading, and study carrels with audio visual equipment to enhance training.

6.3.3 Arrangement Practices (see Part II, Figure 6-2). Provide four areas: librarian's station, book stacks area, study area, and reading area.

6.3.3.1 Librarian's Station. Locate the librarian's station near the access to the space. Position furniture so that the operator can simultaneously serve customers and monitor the whole space. Provide a built-in book return from outside the LMRC to the librarian's station so that books may be returned any time.

6.3.3.2 Book Stacks Area. Provide 1 linear foot of shelving per 5 accommodations on ships with less than 3,000 accommodations. On ships with 3,000 or more accommodations, provide 1 linear foot of shelving per 7 accommodations. Orient shelving athwartship to help retain books as the ship rolls. Ensure a PC with access to the library holding's inventory is near the stacks area to facilitate identifying and locating library media.

6.3.3.3 Study Area. Orient study carrels athwartships. Ensure that adequate clearance is provided for chairs. Provide electrical outlet to audio visual carrels.

6.3.3.4 Reading Area. Locate the magazine rack and paperback book display rack in or near the reading area. Orient reading table and chairs athwartship.

6.4 PHYSICAL FITNESS SPACE.

6.4.1 Function. Provides a place for physical conditioning, including flexibility, strength, and aerobic training. The goal is to provide a sufficient number of exercise stations to permit each crewmember to have three exercise periods per week based upon the requirements of OPNAVINST 6110.1.

6.4.2 Outfit and Furnishings. Provide abdominal unit, arm stations, chest/shoulder machines, exercise support apparatus, latissimus/pulley machines, leg machines, scale, and chinning bar. Equipment metal frames should be corrosion resistant steel or have a durable baked enamel or epoxy powder finish. Use compact equipment for maximum use of space. Specify equipment that is easy to repair and has readily available replacement parts. Additional portable physical fitness equipment may be stowed in the athletic gear storeroom. Provide an entrance/exit control desk and chair or chair without desk if space is limited.

6.4.3 Arrangement Practices. Provide a dedicated physical fitness space in ships with 200 or more accommodations. In smaller ships, provide physical conditioning equipment in a multi-purpose space where its use is compatible with other space functions.

6.4.3.1 **Size.** Size the physical fitness space based on approximately 25 to 50 square feet per piece of exercise equipment with an additional 10 to 15 percent of space for personnel movement.

6.4.3.2 **Location.** Locate physical fitness space near berthing concentrations. In ships with more than 1,000 accommodations, provide multiple physical fitness spaces. Overall configuration of the space is not critical since physical fitness equipment comes in all shapes and sizes and equipment can be matched to the space. Provide adequate clearance around exercise stations for access and operation.

6.4.3.3 **Mirrors.** Provide a full-length and width, segmented mirror on one bulkhead for self-evaluation of technical form in performing exercises.

6.4.3.4 **Equipment Selection.** In small ships with few exercise stations, select equipment that has a small footprint and can train as many muscle groups as possible. In larger ships, where space permits, provide special purpose units. In each crew berthing space, provide at least one chin-up bar.

6.5 **LOUNGE.**

6.5.1 **Function.** Provides a place for quiet pursuits, such as watching TV, reading, studying, writing, and listening to music.

6.5.2 **Outfit and Furnishings.** Provide upholstered furniture, end, corner, and coffee tables with table lamps, magazine rack, TV monitor foundation, and built-in stowage for books, games, stereo system, and recordings. Avoid curved transoms, except in Flag Officer living spaces, due to high fabrication costs. A trophy case for holding and displaying special honors, sporting trophies, and other mementos may be provided as space permits.

6.5.3 **Arrangement Practices (see Part II, Figure 6-3).** Provide approximately 15 square feet per seat. Seating orientations are not of concern, but should have an adequate view of the TV monitor. Seats may be portable. All other furnishings are normally permanently mounted. Outfit lounge spaces with lounge chairs, coffee and end tables, and sofas.

6.5.3.1 **Officer Wardroom Lounge.** Provide adjacent to, or as part of, the officer messroom. Arrange seats and end/corner/coffee tables in groupings. Ensure that there is easy access to the magazine rack and coat and hat hooks. Locate the TV monitor where it affords the best view to the most seats. Where practicable, install the TV monitor in a multi-purpose cabinet that also contains stowage for a stereo system, books, recordings, and games. Install bulkhead and overhead sheathing and ensure that cut-outs and quick-access panels are provided in the sheathing where necessary to access distributive system fittings. Provide carpeting throughout. Ship's force may select and install their own decorative accessories (i.e., pictures, plants, etc.).

6.5.3.2 **CPO/SNCO Lounge.** Provide near CPO berthing spaces. All other lounge arrangement practices are similar to the officer lounge.

6.5.3.3 **Crew/Troop Lounge.** Provide near crew/troop berthing spaces. Sheathing and carpeting are not installed. Other arrangement practices are similar to the officer lounge, except that this space is often not used for TV viewing.

6.6 **RECREATION SPACE.**

6.6.1 **Function.** Provides a place for relaxing, watching TV, listening to music, playing games, studying, writing, and other activities. Recreation space shall be provided for ships with 1,000 accommodations or more, but may be provided for ships less than 1,000 accommodations where space permits. Recreation spaces should be as large as practical and located near a physical fitness area.

6.6.2 **Outfit and Furnishings.** Provide two- and four-person table seating consisting of portable stacking chairs on large ships and fixed outrigger type seating on small ships. Provide TV monitor, magazine rack, trash receptacle, and ship's entertainment system loudspeaker. Recreation spaces may be unsupervised and furnishings are subject to very rough treatment. Furnishings must be durable and easily maintained.

6.6.3 **Arrangement Practices (see Part II, Figure 6-3).** Size recreation spaces based on approximately 15 square feet per seat.

6.6.3.1 **Alternate Functions.** Arrange recreation spaces with consideration for their alternative functions as training areas and additional wartime surge berthing space. Part II, Figure 6-4 shows surge berth stowage for use during wartime when additional surge berthing is required.

6.7 TRAINING.

6.7.1 Function. Provides a place for formal classroom training during normal working hours, and can be used for watching television, movies, lectures, and meetings after hours.

6.7.2 Outfit and Furnishings. Educational seating with tablet arms (fixed mount or stackable). Provide video monitor, marker board, portable lectern, and bulkhead-mounted training aids.

6.7.3 Arrangement Practices. This space has two basic areas: the instruction area for the lecturer and the seating area. In many instances, the instructor may be a TV video. The goal is to provide an adequate instruction area and then maximize seating in the remainder of the space. Provide a secondary egress if the space seats 21 or more persons.

6.7.3.1 Instruction Area. Plan for a lectern, marker boards, TV monitor, and a small amount of walking area. Install large sized marker boards on bulkhead behind lectern and elsewhere, where practicable. Marker board may also be used as a screen for viewing slides and view-graphs.

6.7.3.2 Seating Area. Orient seating facing forward or aft toward the instruction area. Mount appropriate training aids on bulkheads around the seating area.

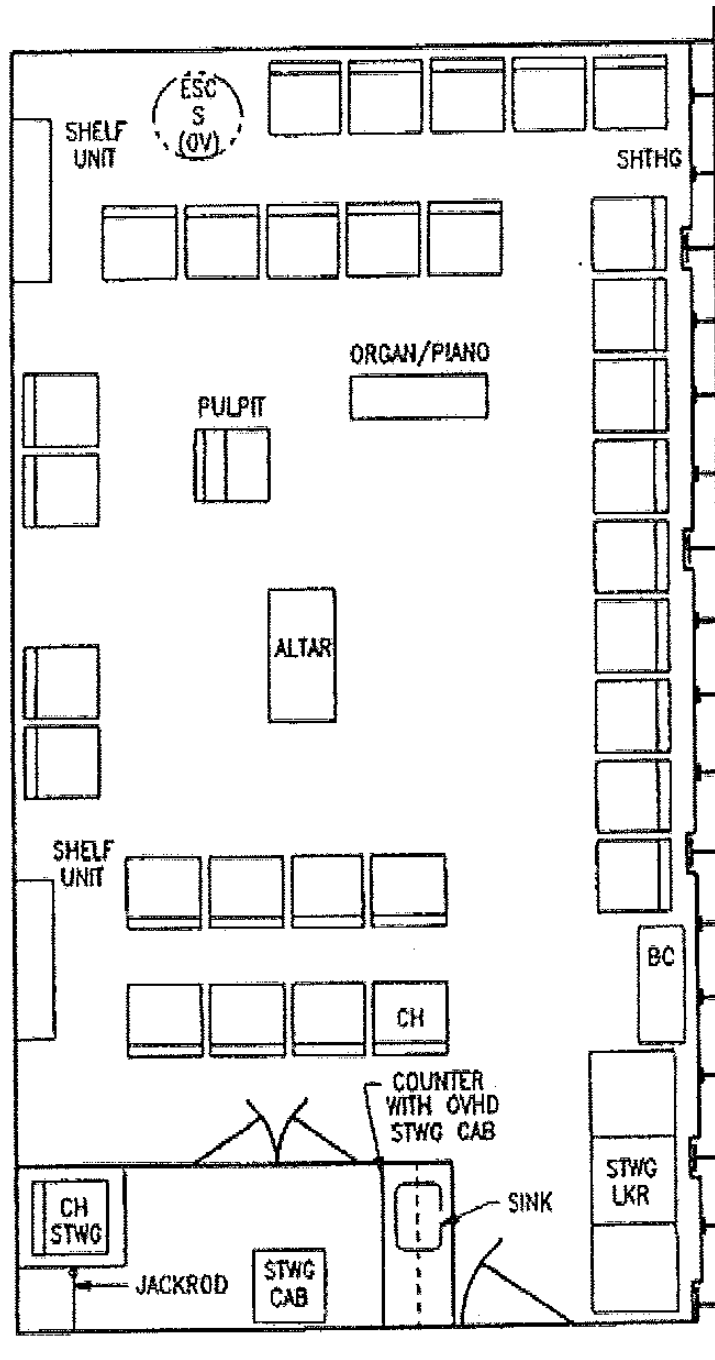

NOTE:

1. Multi-purpose furnishings are portable and may be arranged for worship, prayer, fellowship, education, and training.

Figure 6-1. Typical Chapel.

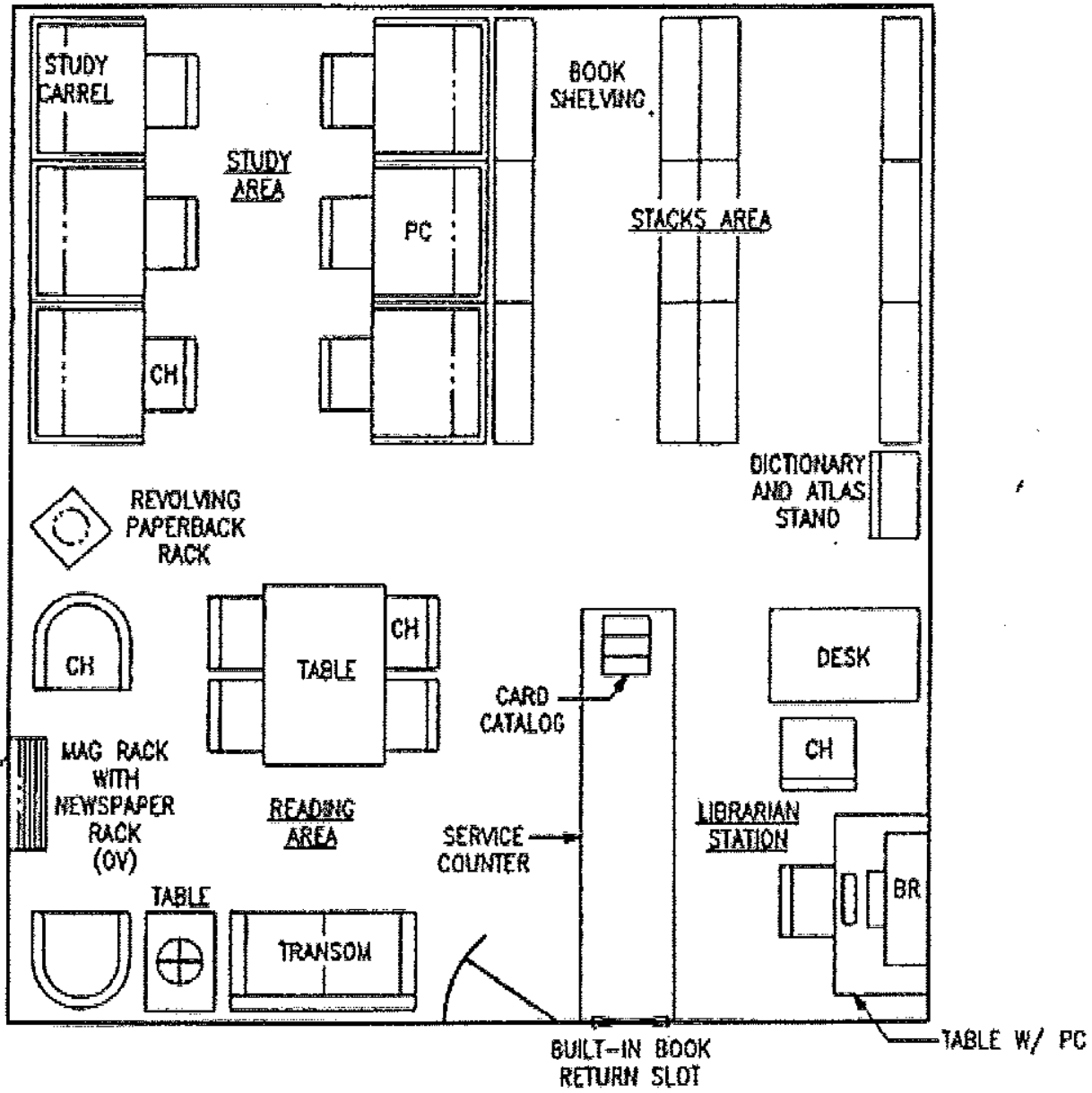
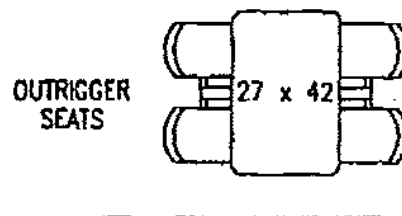
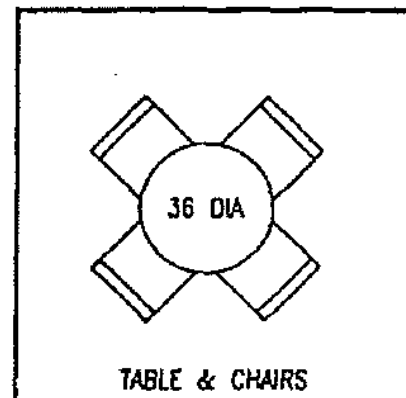
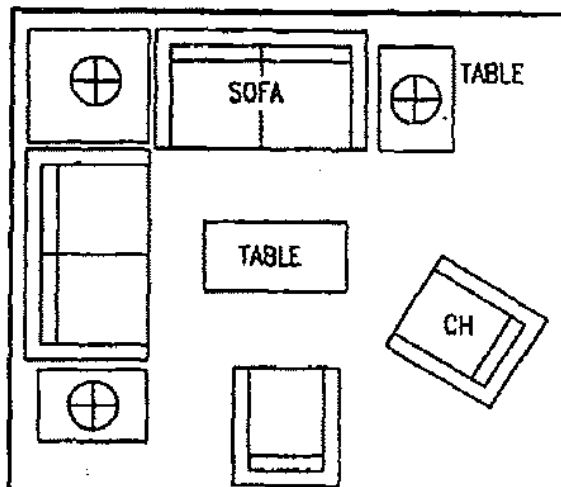
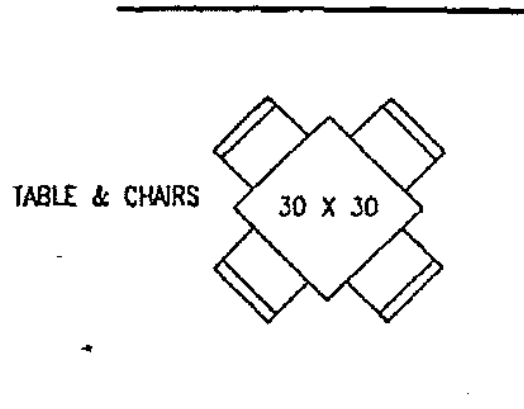
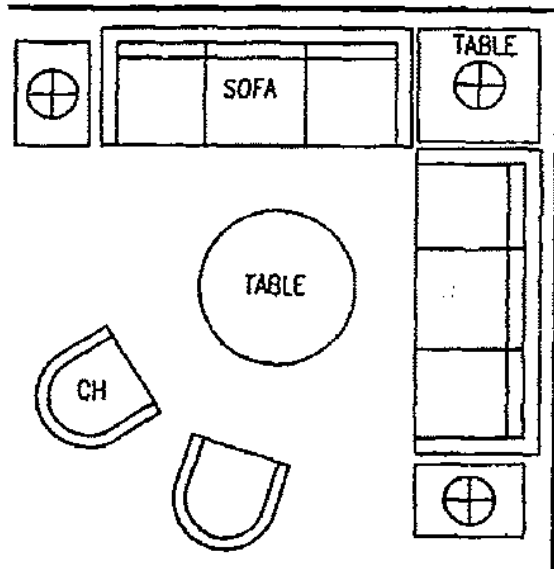

Figure 6-2. Typical LMRC.



LOUNGE SEATING GROUPS

RECREATION SEATING GROUPS

Figure 6-3. Typical Lounge and Recreation Seating Groups.

CHAPTER 7 FOOD SERVICE SPACES

7.1 GENERAL.

The entire system of food service, which includes food handling, storage, preparation, serving, dining, mess gear sanitizing, and garbage disposal, should be considered as an integrated unit. The space configurations should provide for the maximum functional relationship of these spaces. The space configuration, types, and quantities of equipment, and arrangement of equipment, for all food service spaces except messroom seating, is under the cognizance of NAVSUP. NAVSEA is responsible for messroom seating. The number, capacity, and type of food service equipment in the galley and messroom are determined by NAVSUP, based on a large array of factors including, but not limited to; Navy standard core menu (NSCM), cooking requirements, serving time, preparation requirements, sanitation requirements, and accommodations. Food service spaces are identified in Part II, [Table 7-1](#).

Table 7-1. Food Service Spaces.^{1/}

Compartment	Accommodations			
	Less than 200	200 – 799	800 – 3,000	More than 3,000
CO/Flag galley	-	X	X	X
Officer galley	-	X	X	X
Officer pantry	X	-	-	-
Officer messroom	X	X	X	X
Officer scullery	-	X	X	X
CPO galley	-	X	X	X
CPO messroom	X	X	X	X
CPO scullery	-	X	X	X
Galley/centralized galley	X	X	X	X
Vegetable prep area	X	X	X	X
Meat prep area	X	X	X	X
Utensil wash area	X	X	X	X
Serving annex	X	X	X	X
Crew messroom	X	X	X	X
Extended serve line	X	X	X	X
Beverage island	-	-	X	X
Crew scullery	-	X	X	X
Provisions issue room	-	X	X	X
Thaw room	-	-	X	X
Bakery	-	-	X	X
Bread room	-	X	X	X
NOTE:				
^{1/} The centralized galley concept, and variations of the centralized galley concept, should be considered for all ship types.				

7.1.1 Galley Type – Centralized Galley (see Part II, [Figure 7-1](#)). The centralized galley is a one-galley configuration. Food for all personnel is prepared in one galley. The centralized galley provides the type of service required to separate messrooms for officers, CPOs, and crew. The centralized galley reduces manning, weight, and cost. If a large enough space is not available to provide a full centralized galley, a single galley for CPOs and crew and a separate galley for the officers are recommended.

7.1.2 Type of Service.

- a. Officer – traditional steward service, family style, buffet, and cafeteria
- b. CPO – buffet and cafeteria
- c. Crew – cafeteria

7.1.3 Location. The area of the ship with the largest subdivision is generally best suited for food service spaces. Food service spaces should be in an area that is convenient to the personnel served and least affected by ship's motion and vibration. The galley should not be located over tanks or the refrigerated storeroom. When selecting the location for food service spaces, consideration should be given to personnel access, including formation of mess lines in good and inclement weather, and access to freeze, chill, and dry provisions storerooms. The scullery location should be coordinated with the location of tables and traffic flow within the messroom. Where queue lines form for food serving lines, the dispensing of consumables, or where soiled food trays or dishes are disposed of, they shall not interfere with normal personnel (through) traffic. The preferred location for food service spaces is amidships on or above the damage control deck in order to provide maximum fore and aft access.

7.2 OUTFIT AND FURNISHINGS.

7.2.1 Food Service Spaces. Food service equipment is specified by NAVSUP. These spaces are provided with CRES bulkhead and overhead sheathing in accordance with 804-5000991 and 804-5000994. For food service spaces, deck coverings shall be selected in accordance with NAVSEA Standard Item 009-26.

7.2.2 Messroom. Food service equipment, such as salad bars, beverage stands, ice dispensers, and beverage dispensers, that are installed in the messrooms are specified by NAVSUP. Equipment other than food service equipment and the number of mess seats required is determined by NAVSEA. The following is provided as guidance in selecting equipment.

7.2.2.1 Officer Messroom. Officers are provided arm chairs and 36-inch deep mess tables that provide 27 inches of seating space width per occupant. Sideboards are provided for stowage of flatware, linen, and condiments. Bulkheads and overheads are treated with decorative sheathing.

7.2.2.2 CPO Messroom. CPOs are provided arm chairs and 36-inch deep tables that provide 27 inches of seating space width per occupant. Bulkheads and overheads are treated with decorative sheathing.

7.2.2.3 Crew Messroom. The crew is provided 27-inch deep tables with outrigger type seats on small ships, and tables with stacking chairs on large ships. Tables with booth/transom seating may also be provided on small and large ships. Tables shall provide 27 inches where practicable, but not less than 24 inches, of seating space width per occupant. Tables and chairs in messrooms which are designated for weapons handling shall be portable. Bulkheads and overheads are not treated with decorative sheathing.

7.3 ARRANGEMENT PRACTICES.

7.3.1 Food Preparation Spaces. Arrangement of equipment in food preparation spaces will vary with the number of accommodations served and the personnel category (officer, CPO, or crew) of these accommodations. Each space requires a different set of design principles which govern the arrangement, due to differing personnel category and method of food service. The arrangement of equipment is developed or directed by NAVSUP.

7.3.2 Messrooms. Arrangement of equipment in messrooms will vary with the number of accommodations served and the personnel category (officer, CPO, or crew) of these accommodations. Each space requires a different set of design principals that govern the arrangement, due to differing personnel category and method of food service.

Arrangement of tables in the officer and CPO messrooms should be coordinated with NAVSUP, considering the type of service being provided by the galley. Arrangement of tables in the crew messroom should also be coordinated with NAVSUP, considering the location of their extended serving line equipment. See Part II, [Figure 7-2](#) for typical crew messroom arrangement.

Where booth seating is provided, four-person booth seats should be open at both ends in order to provide ease of access for personnel and avoid trapping seated diners. When limited area precludes the use of a four-person booth seating, six-person booth seating may be used on a limited basis with NAVSEA approval.

7.4 DESIGN PARAMETERS FOR ESTABLISHING FOOD SERVICE EQUIPMENT REQUIREMENTS.

7.4.1 Galley Equipment.

7.4.1.1 Refrigeration for Chilled Foods, Leftovers, and Thawing Meat.

- a. For accommodations less than 636, refrigeration is provided with meat thaw capacity.
- b. For accommodations greater than 636, refrigeration provided is without meat thaw capacity, except add for Friday, Saturday, Sunday daily provisions, and Monday's breakfast for daily breakouts based on ship in port duty.
 - (1) Crew – Refrigerated space with meat thaw capacity: 2.5 cubic feet plus 0.1943 cubic feet/person.
 - (2) Officer/CPO – Refrigerated space with meat thaw capacity: 2.5 cubic feet plus 0.3474 cubic feet/CPO and Officer.
 - (3) Crew – Refrigerated space without meat thaw capacity: 2.5 cubic feet plus 0.0703 cubic feet/person.
 - (4) Officer/CPO – Refrigerated space without meat thaw capacity: 2.5 cubic feet plus 0.2234 cubic feet/CPO and Officer.

7.4.1.2 Frozen Food Cabinet.

- a. Crew – For frozen vegetables, fruit, meat, poultry, and fish: 0.015 cubic feet/person.
- b. Officer/CPO – For frozen vegetables, fruit, meat, poultry, and fish: 0.0936 cubic feet/CPO and Officer.

7.4.1.3 Meat Thaw.

- a. Where built-in refrigerated meat thaw rooms are required, meat thaw racks are required in accordance with 805-2253565 and 805-2253566.
- b. Each meat thaw rack is equipped with five shelves. Each shelf can support enough meat for 44 personnel.
- c. Where built-in refrigerated meat thaw rooms are not required, reach-in thaw boxes are available from U.S. Navy Food Service Equipment Catalog S6161-Q5-CAT-010 (see <http://usnhabeqptcatalog.gdit.com/>).

7.4.1.4 Combination Ovens.

- a. For accommodations less than 636, recommend one double oven be installed to incorporate bakery functions.
- b. Oven Capacity:
 - (1) Crew – One single deck, hatchable combination oven will support 200 accommodations.
 - (2) Crew – One double deck, hatchable combination oven will support 400 accommodations.
 - (3) Officer/CPO – One single deck, hatchable combination oven will support 200 accommodations.
 - (4) Officer/CPO – One double deck, hatchable combination oven will support 400 accommodations.

7.4.1.5 Steam Jacketed Kettles. The steam jacketed kettles are used for soup, large meats and vegetables, small meats and vegetables, and sauces and gravy. Steam jacketed kettles are available from U.S. Navy Food Service Equipment Catalog S6161-Q5-CAT-010 (see <http://usnhabeqptcatalog.gdit.com/>). The following calculation is used for establishing kettle size:

$$\frac{A(B \times C)}{D \times F} = E$$

Where:

A = accommodations (ship's complement)

B = portion size (soup: 0.086; large meats and vegetables: 0.250; small meats and vegetables: 0.250; sauces and gravy: 0.032)

C = acceptability (soup: 40%; large meats and vegetables: 100%; small meats and vegetables: 70%; sauces and gravy: 100%)

D = utilization of kettle capacity (75 percent)

E = gallons

F = batches (2)

(1) Soup: $(A \times 0.086 \times 0.4) \div (0.75 \times 2) =$ gallons

(2) Large meats and vegetables: $(A \times 0.250 \times 1) \div (0.75 \times 2) =$ gallons

(3) Small meats and vegetables: $(A \times 0.250 \times 0.7) \div (0.75 \times 2) =$ gallons

(4) Sauces and gravy: $(A \times 0.032 \times 1) \div (0.75 \times 2) =$ gallons

7.4.1.6 Skittles Cooker. Skittles (or equal with Navy approval) are available from U.S. Navy Food Service Equipment Catalog S6161-Q5-CAT-010 (see <http://usnhabeqptcatalog.gdit.com/>).

a. The Skittle cooker is a multi-functional piece of equipment. It can be used as a steamer, tilting skillet, griddle, kettle, holding cabinet, and roaster.

b. For accommodations less than 636, recommend one 5-pan Skittle installed per serving line.

c. For accommodations greater than 636, recommend two 5-pan Skittles installed per serving line.

7.4.1.7 Holding Cabinet. Holding cabinets are available from U.S. Navy Food Service Equipment Catalog S6161-Q5-CAT-010 (see <http://usnhabeqptcatalog.gdit.com/>).

a. For accommodations less than 636, recommend one full size 28 inches wide by 30 inches deep by 60 inches high insulated holding cabinet be installed per serving line.

b. For accommodations greater than 636, recommend two full size 28 inches wide by 30 inches deep by 60 inches high insulated holding cabinets be installed per serving line.

7.4.1.8 Serving Line. Equipment listed below is available from U.S. Navy Food Service Equipment Catalog S6161-Q5-CAT-010 (see <http://usnhabeqptcatalog.gdit.com/>).

a. Hot food well drop-in:

(1) Recommend the units not requiring water or drains be installed on the serving lines.

(2) Minimum of four drop-in serving line hot food wells for accommodations 47 – 147. (LCS Class Ships)

(3) Minimum of five drop-in serving line hot food wells for accommodations 128 – 325. (Small Boys)

(4) Minimum of six drop-in serving line hot food wells per serving line for accommodations 326 – 532.

(5) Minimum of seven drop-in serving line hot food wells per serving line for accommodations 533 – 1,000+.

b. Insulated hot holding cabinets, 28 inches wide by 30 inches deep by 30 inches high, should be installed under counter below the drop-in hot food wells located on the serving lines.

c. Griddles:

(1) Three-foot serving line griddle will support 3.6 persons per minute through the serving line.

(2) Six-foot serving line griddle will support 7.2 persons per minute through the serving line.

- d. Food mixer:
 - (1) Twenty-quart food mixer will support 102 personnel.
 - (2) Thirty-quart food mixer will support 153 personnel.
 - (3) Sixty-quart food mixer will support 305 personnel.
- e. Cold food counter:
 - (1) Three-pan cold food counters will support 125 personnel.
 - (2) Four-pan cold food counters will support 400 personnel.
 - (3) Five-pan cold food counters will support 500 personnel.
 - (4) Six-pan cold food counters will support 1,000 personnel.
- f. Pneumatic can-openers, supplied with ship's low pressure air, shall be provided.
- g. Cereal rack installed at the end of the beverage line by the milk machine.
- h. Silverware rack installed at the head of the serving line.
- i. Soup pot installed at the end of the hot wells on the serving line.

7.4.2 Trash Holding. Trash holding shall be provided in solid waste processing spaces in accordance with S9593-C6-IIN-010.

7.4.3 Messroom Equipment.

7.4.3.1 Mess Gear. All mess gear (trays, bowls, silver ware, plates, and cups/glasses) at the serving areas shall be three times the seating capacity.

7.4.3.2 Hot Food Counters. Hot food counters are available from U.S. Navy Food Service Equipment Catalog S6161-Q5-CAT-010 (see <http://usnhabeqptcatalog.gdit.com/>).

- a. Four-pan hot food counter with two soup warmers for accommodations from 76 to 325.
- b. Six-pan hot food counter with two built-in plate dispensers and two soup warmers for accommodations from 326 to 532.

7.4.3.3 Refrigerated Salad Bar.

- a. Three-pan salad bar will support 125 personnel.
- b. Four-pan salad bar will support 400 personnel.
- c. Five-pan salad bar will support 500 personnel.
- d. Six-pan salad bar will support 1,000 personnel.

7.4.3.4 Refrigerated Milk Dispenser.

- a. Five-gallon milk dispenser will support 80 personnel.
- b. Ten-gallon milk dispenser will support 160 personnel.
- c. Fifteen-gallon milk dispenser will support 240 personnel.

7.4.3.5 Refrigerated Milk Storage Stand.

- a. Five-gallon milk storage stand will support 80 personnel.
- b. Ten-gallon milk storage stand will support 160 personnel.
- c. Fifteen-gallon milk storage stand will support 240 personnel.

7.4.3.6 Refrigerated Beverage Dispenser.

- a. Five-gallon beverage dispenser will support 80 personnel.
- b. Two 5-gallon beverage dispensers will support 160 personnel.
- c. Three 5-gallon beverage dispensers will support 240 personnel.

7.4.3.7 **Refrigerated Ice Dispenser.** Ice/water and bulk ice dispensers are available from U.S. Navy Food Service Equipment Catalog S6161-Q5-CAT-010 (see <http://usnhabeqptcatalog.gdit.com/>). Sixty percent of total ice making capacity is required on the serving line for main service of the crew during meal hours. Forty percent is for bulk ice makers.

7.4.3.8 **Ice Cream Making Equipment.** Ice cream making equipment and freezer chests are available from U.S. Navy Food Service Equipment Catalog S6161-Q5-CAT-010 (see <http://usnhabeqptcatalog.gdit.com/>).

- a. One single-head ice cream dispenser will produce 12 gallons/hour.
- b. One twin-head ice cream dispenser will produce 30 gallons/hour.

7.4.3.9 **Beverage Service Stand.** Beverage stand shall be fabricated in accordance with 804-6983470.

7.4.3.10 **Coffee Urn.** Coffee urns are available from U.S. Navy Food Service Equipment Catalog S6161-Q5-CAT-010 (see <http://usnhabeqptcatalog.gdit.com/>). Coffee urns shall have a 1- to 3-gallon capacity/compartments, and 6-gallon total capacity per beverage line.

7.4.4 **Bakery.** For accommodations less than 750, baking is provided in the ship's galley. For accommodations greater than 750, a separate bake shop is required.

7.4.4.1 **Bakery Equipment.** Equipment listed below is available from U.S. Navy Food Service Equipment Catalog S6161-Q5-CAT-010 (see <http://usnhabeqptcatalog.gdit.com/>).

- a. Food mixer (ship accommodations determines the selection of mixers):
 - (1) Five-quart food mixer.
 - (2) An 80-quart food mixer will support 864 personnel.
 - (3) Horizontal food mixer with two barrels will support 1,566 personnel.
- b. Dough roller divider:
 - (1) A 36-part dough roller divider can be bench- or stand-mounted.
 - (2) An 18-part dough roller divider can be bench- or stand-mounted.
 - (3) A dough roller divider can be provided as a hand-operated unit or electric.
- c. Dough sheeter conveyor can be bench- or stand-mounted.
- d. Combination oven:
 - (1) The combination oven can be used for baking and proofing.
 - (2) The two-deck (double stacked or one bank) combination oven can accommodate 12 five-strap bread pans, six in each cavity, providing 60 loaves of bread production.
- e. Refrigerator:
 - (1) The reach-in refrigerators are for normal bakery operation.
 - (2) The 15 cubic feet reach-in refrigerator will support 750 to 1,999 personnel.
 - (3) The 30 cubic feet reach-in refrigerator will support 2,000 and above personnel.
- f. Bread slicing machine:
 - (1) The bread slicing machine can be counter-top, manual feed chute, dresser-mounted.
 - (2) The bread slicing machine can be gravity feed chute, deck-mounted.
- g. Pneumatic can-openers, supplied with ship's low pressure air, shall be provided.
- h. Bread, pie, cake, and sheet pan storage racks shall be fabricated in accordance with 805-1631454.
 - (1) One pie basket shall be provided for each 36 total accommodations. Each section of the pie storage rack will hold 62 pie baskets.
 - (2) One bread basket shall be provided for each 15 total accommodations. Each section of the bread storage rack will hold 32 bread storage baskets.
 - (3) Stowage shall be provided for one sheet pan for each 17 total accommodations. Each section of the sheet pan storage rack will hold 62 sheet pans.

7.4.5 Provision Issue Room. For accommodations greater than 150, provision issue rooms are required and outfitted in accordance with the following:

- a. The bulk stowage area is composed of deck and overhead gratings and portable battens supporting 0.06 square feet per accommodation.
- b. The bulk stowage area also includes 45 cubic feet of shelf space for loose items. The administrative area is provided with a single pedestal flat-top desk, chair, file cabinet (Type B in accordance with U. S. Navy furniture catalog S9600-AD-GTP-010 (see <http://usnhabeqptcatalog.gdit.com/>), and a scale (Type 2 in accordance with S9600-AD-GTP-010).

7.4.6 Vegetable Preparation Area. For accommodations less than 450, vegetable preparation is provided in the ship galley. For accommodations greater than 450, a separate vegetable preparation room is required with a 12-foot by 12-foot walk-in refrigerator.

7.4.6.1 Vegetable Preparation Equipment. Equipment listed below is available from U.S. Navy Food Service Equipment Catalog S6161-Q5-CAT-010 (see <http://usnhabeqptcatalog.gdit.com/>).

- a. Dresser with two-compartment sink shall be 24 inches by 24 inches.
- b. Food processor bowl, capacity 14 ounces, dresser-mounted, shall be provided.
- c. Meat slicers, automatic operated, that include built-in sharpener and variable speed control, shall be provided.
- d. Pneumatic can-openers, supplied with ship's low pressure air, shall be provided.
- e. Vegetable peelers, capacity 15 pounds, dresser-mounted, shall be provided.
- f. Under-counter refrigerator or walk-in refrigerator shall be provided.

7.4.7 Utensil Wash Room Equipment.

7.4.7.1 Dresser.

- a. Install dresser with three-compartment sink that is 24 inches by 24 inches.
- b. Install dresser with scrap sink that is 24 inches by 24 inches.

7.4.7.2 Sanitize Sink Heater. Sink heater (9kW) requires connection to an external water heater providing a minimum water temperature of 140 °F. Sink heaters are available from U.S. Navy Food Service Equipment Catalog S6161-Q5-CAT-010 (see <http://usnhabeqptcatalog.gdit.com/>).

7.4.7.3 Food Waste Disposer (FWD). Provide and install a FWD below the scrap sink in the utensil wash area with a hand sprayer hose. See 593-7556875 for FWD requirements and installation guidance.

7.4.7.4 Pot Scrubber/Utensil Washer. Pot scrubbers are used for scrubbing stock pots, steam table, and bake sheet pans. Pot scrubbers are available from U.S. Navy Food Service Equipment Catalog S6161-Q5-CAT-010 (see <http://usnhabeqptcatalog.gdit.com/>).

7.4.7.5 Utensil Storage Racks. Provide and install utensil storage rack with shelving that is 36 inches wide by 24 inches deep by 60 inches high.

7.4.8 Scullery Equipment.

7.4.8.1 Dishwashing Machines. The following dishwashing machines are acceptable and are available from U.S. Navy Food Service Equipment Catalog S6161-Q5-CAT-010 (see <http://usnhabeqptcatalog.gdit.com/>):

- a. Double tank type (steam) right-hand feed.
- b. Double tank type (steam) left-hand feed.
- c. Double tank type (electric) right-hand feed.
- d. Double tank type (electric) left-hand feed.
- e. Single tank door type (steam).
- f. Under counter type (steam).
- g. Under counter type (electric).

7.4.8.2 Dresser (Fabricated). A dresser to incorporate a soak sink that is 24 inches by 18 inches and a scrap sink that is 24 inches by 36 inches shall be installed at the feed end of the dishwasher. Provide and install a tray pre-rinse unit above the scrap sink.

7.4.8.3 FWD. Provide and install a FWD below the scrap sink in the utensil wash area. See 593-7556875 for FWD requirements and installation guidance.

7.4.8.4 Roller Conveyor. Roller conveyor sections with drain pans underneath shall be installed at the clean end of the dishwasher.

7.4.8.5 Storage. There shall be storage for three times per messroom seating for each dinnerware item including trays, cups, glasses, bowls, plates, and silverware.

7.4.8.6 Mess Gear Dispensers for 65 Percent of Crew Size. Mess gear dispensers are available from U.S. Navy Food Service Equipment Catalog S6161-Q5-CAT-010 (see <http://usnhabeqptcatalog.gdit.com/>). Mess gear includes trays, cups and glasses, bowls, plates, and cutlery.

7.4.9 Flag/CO Galley Equipment. The following equipment is available from U.S. Navy Food Service Equipment Catalog S6161-Q5-CAT-010 (see <http://usnhabeqptcatalog.gdit.com/>):

7.4.9.1 Combination Convection-Steam Oven. The oven shall be a single compartment unit.

7.4.9.2 Griddle. Leg mounted, counter top model.

7.4.9.3 Steam Jacketed Kettles. Self-contained electrically heated; Capacity D, Style 3, Class C; tilting.

7.4.9.4 Refrigerator/Freezer. The refrigerator/freezer shall be 20 cubic feet (reach-in).

7.4.9.5 Mixer. The food mixer shall be size 5.

7.4.9.6 Ice Maker/Dispenser. Counter-mounted 15-pound capacity with external water dispensing.

7.4.9.7 Beverage Dispenser. Non-carbonated, Type 2, Class A, Style B, Size 1.

7.4.9.8 Coffee Maker. A coffee maker with three warmer unit, water hookup, and hot water spout shall be provided.

7.4.9.9 Dishwashing Machine. Under-counter dishwashers shall support 45 racks an hour.

7.4.9.10 Toaster. Pop-up, counter top, four-slot.

7.4.9.11 Waffle Iron. Double, 7 inches round waffle maker.

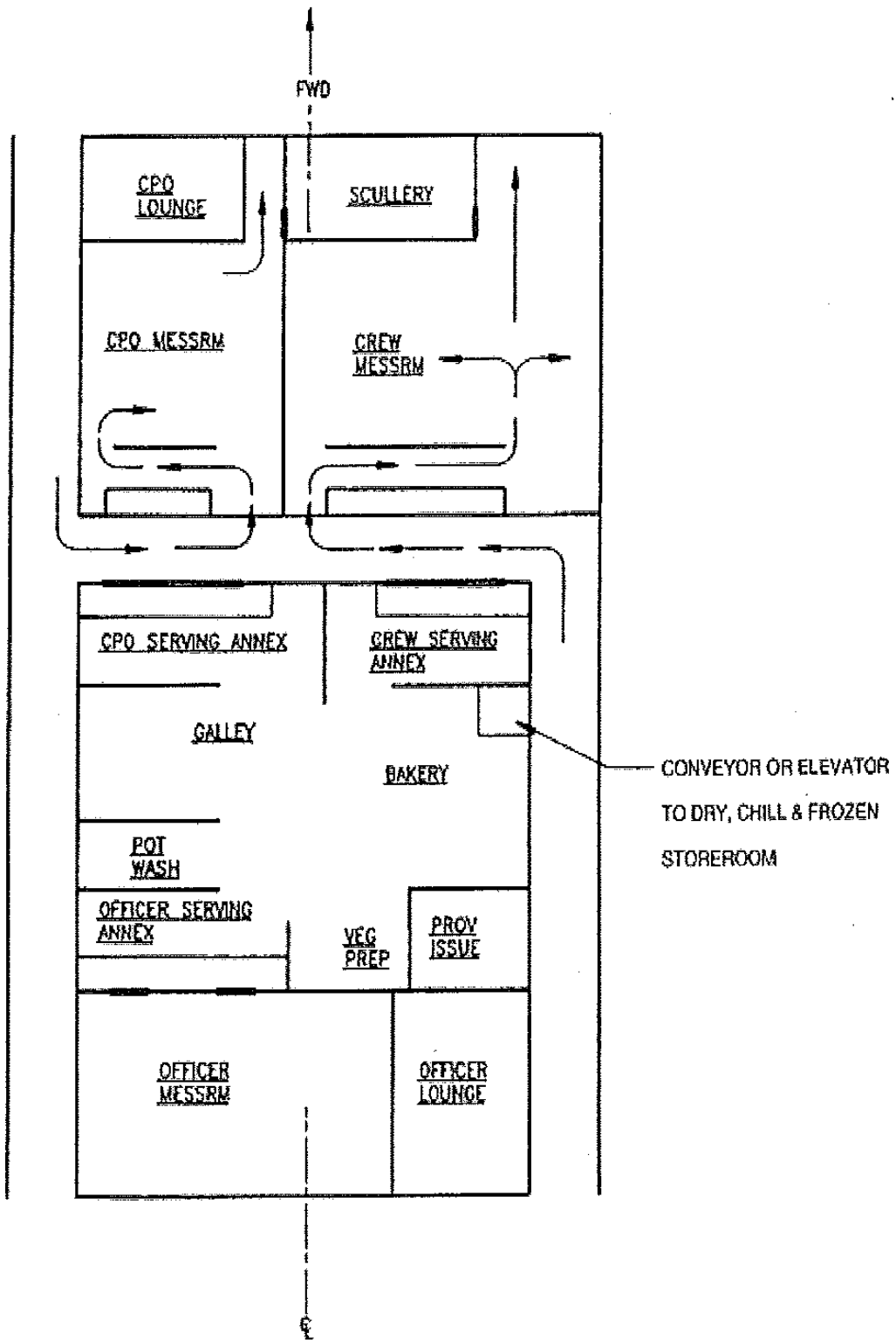
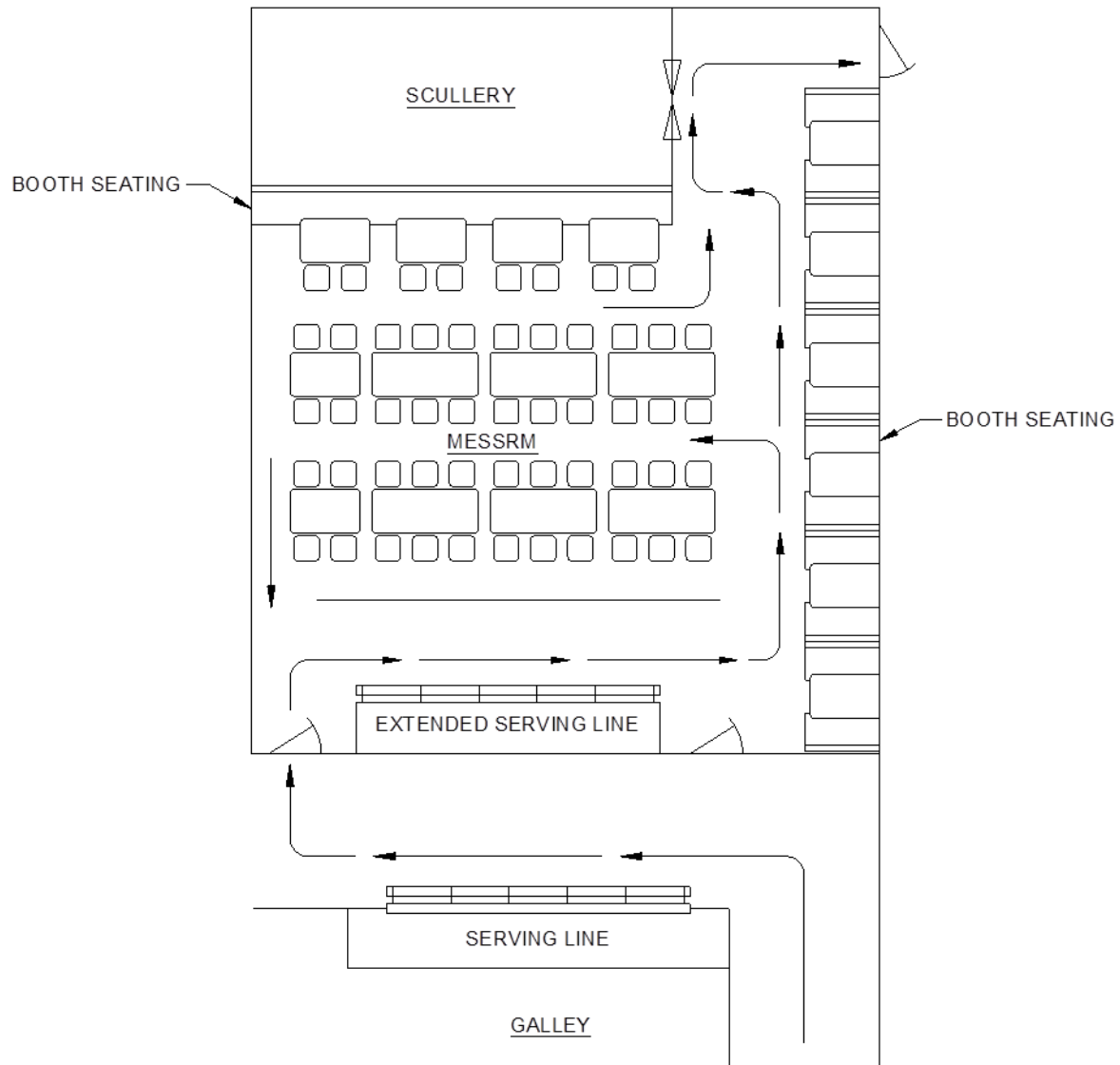

Figure 7-1. Centralized Galley Concept.



NOTE:

1. Messdeck arrangement should have a circle flow of traffic which allows seated diners to return to the beverage line without creating a bottleneck with personnel in or exiting from the extended serving line.

Figure 7-2. Typical Crew Messroom.

CHAPTER 8 SERVICE SPACES

8.1 GENERAL.

The space configuration, types, quantities, and arrangement of equipment in the service spaces (except for the brig) are under the cognizance of NAVSUP and Naval Exchange Command (NEXCOM). BUPERS is responsible for the brig. Service spaces include the barber shop, ship store, snack bar, vending machines area, and brig. They serve all ship personnel. Service spaces, except the brig, may be grouped together in a complex or separately distributed throughout the ship. Most service spaces, except the brig, require space for customers to wait in line before being served. Provide wide passages or alcoves outside these spaces so that customers will not interfere with general ship traffic.

8.2 BARBER SHOP.

Provide all ships with either portable barber facilities or a barber shop.

8.2.1 Location. Locate aft of amidships to improve barber performance by minimizing ship motion effects.

8.2.2 Operation. Hours of operation are based on providing each crew member with a regulation haircut about every 2 weeks at about 15 minutes per haircut. Ship servicemen are trained to cut hair for both males and females.

8.2.3 Outfit and Furnishings. Barber shops are outfitted with the following: counter with sink and mirror, barber chairs, waiting chairs, supply cabinet, magazine rack, and coat/hat rack. Barber shop furniture and equipment shall be provided in accordance with Part II, [Tables 8-1](#) and [8-2](#) and U.S. Navy furniture Catalog S9600-AD-GTP-010 (see <http://usnhabeqptcatalog.gdit.com/>).

Table 8-1. Officer Barber Shop Outfit Quantities.

Item	Drawing or spec. no.	Officer accommodations		
		75 – 200	201 – 400	400+
Barber shop counter unit	As specified	1	2	3
Chair, barber	804-4661744	1	2	3
Chair	As specified	2	4	6
Coat and hat hooks		3	6	9
Locker, barber supply	805-1629991	1	1	1
Locker, cleaning gear	S3605-630718	1	1	1
Magazine rack, Type A	S3304-860200	1	1	2
Mirror	805-2253852	1	1	1
Rubber mat		1	2	3

Table 8-2. Enlisted Personnel Outfit Quantities.

Item	Drawing or spec. no.	Enlisted personnel accommodations			
		101 – 300	301 – 600	601 – 900	901 – 1,200
Barber shop counter unit	As specified	1	2	3	4
Chair, barber	804-4661744	1	2	3	4
Chair	As specified	1	2	3	4
Coat and hat hooks		2	4	6	8
Locker, barber supply	805-1629991	1	1	1	1
Locker, cleaning gear	S3605-630718	1	1	1	1
Magazine rack, Type A	S3304-860200	1	1	1	1
Mirror	805-2253852	1	1	1	1
Rubber mat		1	2	3	4
		1,201 – 1,500	1,501 – 1,800	1,801 – 2,100	2,101 – 2,400
Barber shop counter unit	As specified	5	6	7	8
Chair, barber	804-4661744	5	6	7	8
Chair	As specified	5	6	7	8
Coat and hat hooks		10	12	14	16
Locker, barber supply	805-1629991	1	1	1	1
Locker, cleaning gear	S3605-630718	1	1	1	1
Magazine rack, Type A	S3304-860200	1	2	2	2
Mirror	805-2253852	1	1	1	1
Rubber mat		5	6	7	8

NOTES:

1. If a separate officer barber shop or troop barber shop is not provided, the enlisted personnel barber shop shall be equipped to service the total personnel accommodations.
2. Where enlisted accommodations are in excess of 2,400, the required quantities of equipment shall equal the sum of the quantity required for 2,400 accommodations plus the quantity in this table required for that number of accommodations in excess of 2,400.

8.2.4 **Arrangement Practices** (see Part II, [Figure 8-1](#)). Provide approximately 60 square feet per barber chair. The barber shop has two distinct areas: the working area and the waiting area. The working area includes the barber chairs, standing mats, cabinets, lockers, and counters. The waiting area contains the customer waiting chairs, magazine rack, and coat/hat rack. In large ships with multiple barber shops, arrange and outfit all shops in the same manner.

8.2.4.1 **Barber Chairs**. Barber chairs have two clearance circles: a turning circle determined by the rotation of the chair and a working circle which includes clearance for the barber. Ensure that both turning and working circles are clear of obstructions. Working circles of adjacent barber chairs may overlap each other to conserve space. Barber chairs shall be non-reclining and provided with hydraulic hoist to raise/lower the chair. Chairs shall be able to lock in position to avoid incidental rotation due to ship’s motion.

8.2.4.2 **Counters**. Orient barber counters that contain a sink athwartship to minimize splash due to ship roll. Orient other items of outfit to best suit the arrangement. Counter tops shall be stainless steel.

8.3 SHIP STORE.

Two types of ship stores are provided in surface ships: walk-in stores and window-service stores. The walk-in store can handle several shoppers at once inside the store, while the window service store serves one person at a time across a counter.

8.3.1 **Location.** Locate near general ship activity; avoid out-of-the-way locations due to the lower expectation of sales and increased security risk.

8.3.2 **Operation.** Ship stores sell snacks, clothing, uniform accessories, personal hygiene products, and some luxury items (watches, cameras, audio and video equipment). Profits go towards the ship's morale, welfare, and recreation fund, which supports activities such as movies, parties, sporting events, tours in foreign ports, and many other recreational activities. These profits are important to crew morale.

8.3.3 **Outfit and Furnishings.**

8.3.3.1 **Walk-In Ship Store.** Provide a walk-in store in ships having more than 300 accommodations. Walk-in stores have demonstrated significantly higher sales than window service stores because they permit a more effective display of merchandise, allow customers the opportunity to examine the merchandise, and stimulate impulse buying. Walk-in stores have two areas: the display area containing display shelving, merchandising aids, and gondolas; and the operator's area containing showcases, cash and wrap counter, register stands, stool, and a limited amount of display shelving. Shopping baskets shall also be provided. The walk-in store furniture and equipment shall be provided in accordance with the U.S. Navy Shipboard Furniture Catalog S9600-AD-GTP-010, Chapter 8 (see <http://usnhabeqptcatalog.gdit.com/>), and Part II, [Table 8-3](#).

Table 8-3. Walk-In Ship Store.

Item	Drawing or spec. no.
Cash and wrap counter	As specified ^{1/}
Register stand	As specified ^{2/}
Display shelving, bulkhead unit	As specified
Feature end units	As specified
Gondolas and half gondolas	As specified
Mirror, convex, surveillance	As specified
Shopping basket, hand carried	^{3/}
Showcase, countertop display	As specified
Showcase	As specified
Stowage stand for shopping baskets	As specified
NOTES:	
^{1/}	Countertop shall be reinforced to support monitor, scanner, and other point of sale media.
^{2/}	Point of sale components are electronic media. Contact NEXCOM Ships Store Program for current configuration.
^{3/}	Baskets shall be as specified of wire mesh material. Provide 5 baskets for up to 800 accommodations and add 1 basket for every 500 accommodations over 800.

8.3.3.2 **Window-Service Ship Store.** Provide a window-service store, also called an over-the-counter store, in surface ships where space considerations preclude having a walk-in store. Window-service stores shall be provided with display case units to advertise the merchandise and assist customers in determining their purchases prior to being served. Other store fixtures shall be consistent with those of a walk-in store as listed in [Table 8-3](#), as space permits.

8.3.4 Arrangement Practices.

8.3.4.1 Walk-In Ship Store (see Part II, Figure 8-2). Base walk-in store size on approximately 0.6 square feet per accommodation. Limit maximum store size to approximately 1,100 square feet to maintain effective operator supervision.

8.3.4.1.1 Traffic Flow. Arrangement should promote unidirectional traffic flow from the entrance through the displays to the checkout counter and out the exit. Where practicable, provide separate entrance and exit doors. Provide enough walkway clearance to ensure traffic does not become congested when persons stop to examine merchandise.

8.3.4.1.2 Shopping Baskets. Provide shopping baskets and stand in store near the entrance to the store.

8.3.4.1.3 Store Front. Provide laminated safety glass display case, where space permits, for adding visual interest to the store to promote impulse buying.

8.3.4.1.4 Door. Provide laminated safety glass doors for adding visual interest to the store and for monitoring the store when it is secured.

8.3.4.1.5 Security. Install an intruder alarm or security gate at the store door. Display windows, showcases, and doors shall be installed using tamper-proof fasteners. Install convex surveillance mirrors, where needed, so that the operator may view all parts of the store from operator's station. Provisions shall be provided for closed circuit camera monitoring of the walk-in ship store.

8.3.4.1.6 Display Area. Maximize use of display shelving, gondolas, and feature end units within the display area while maintaining adequate aisle clearances. Orient units so that the store operator may monitor as many as possible without convex mirrors.

8.3.4.1.7 Showcases. Provide showcase units for high priced items, such as cameras and electronics equipment, at the operator's station to ensure close supervision of these items and so the operator may assist customers. Showcases shall be approximately 22 inches deep by 39 inches high, and at lengths determined by space considerations. Provide showcase with one shelf, 12 inches below the countertop, and running the full width and depth of the unit. Provide with mirrored sides. Contractor shall ensure that countertop provides adequate support. The section below the display shelf shall be lockable storage with one adjustable height metal shelf, minimum 12-gauge. Provide sliding access doors capable of being locked. Provide sliding doors with upper and lower retainer tracks. The countertop shall be minimum 3/8 inch thick tempered safety plate glass. The doors, shelves, and other transparent or mirrored polycarbonate material shall be at least 1/4 inch thick. Provide the display shelf area with interior LED lighting. Display lighting must illuminate all areas of showcase interior sections when shelves are stocked with product/display items. Interior lighting shall be UL listed.

8.3.4.1.8 Register Stand. Locate the register stand at the operator's station so that operator may continue to monitor the store and customers while making a transaction. Secure all point of sale (POS) media to the counter. Register stands shall have a continuous level surface with countertop surfaces. Provisions/brackets shall be provided to mount the monitor and POS components (monitor, printer, scanner, etc.). Provide cable penetrations through top surface and cable/cord relief to bottom of unit. Stands are to have a computer shelf below the top surface, with ventilation perforations, and a pull-out keyboard tray. Provide the stands with a lockable, 6-inch deep drawer below the computer area, with a pull handle. Provide lockable doors on lower section. Unit shall be approximately 24 inches wide by 22 inches deep by 39 inches high, and provided with a 3-inch high sub-base (black in color).

8.3.4.1.9 Case Breakout. Where practical, provide a ship store storeroom adjacent to the store, with direct access as practical, for case breakout and resupply. Designate special stowage within ship store storeroom for ship store flammables and design in accordance with SDS 077-1. Where breakout storerooms are not practical, provide lockable storage within the store.

8.3.4.2 Window-Service Ship Store (see Part II, Figure 8-3). Base store size on approximately 0.3 square feet per accommodation up to a maximum size of approximately 120 square feet.

8.3.4.2.1 Service Window. Provide a service window with CRES roller curtain closure for serving customers. Provide a counter in way of the service window.

8.3.4.2.2 Orientation. Arrange the cash register, stock shelves, and display cases for convenient use by the operator and orient them athwartship, where practicable, to improve operator performance by minimizing ship roll effects.

8.3.4.2.3 Security. Install an intruder alarm and security gate at the store door and provide a security gate to cover the service window when the store is not in use. In large ships where security is a greater issue, provide a security gate in front of all display case units.

8.3.4.2.4 Trash. Install a metal, covered bulkhead-mounted trash receptacle in the passage outside the window-service ship store.

8.4 VENDING MACHINE AREAS.

Provide space and weight for candy, canned drink and/or canned drink Vending in a Box (VIB), and snack vending machines in all surface ships.

8.4.1 Location. Locate near concentrations of living and work spaces. Machines may be located in passages where their use does not interfere with ship traffic. Ensure space reservation on general arrangement drawings to avoid passage clearance violations later in the design process. Avoid locating machines high in the ship due to weight of the machines and remote location of associated storerooms.

8.4.2 Operation. Most food and drink vending machines and VIBs are continuously available.

8.4.3 Arrangement Practices.

8.4.3.1 Groups. Group vending machines together to simplify resupply. Each group should contain a mix of different machines. In large ships with multiple units of each type, provide several vending machine and/or VIB areas.

8.4.3.2 Stowage. Where practicable, provide a small ship store storeroom near vending machine areas for resupplying the machines.

8.4.3.3 Clearance. Ensure doors to machines can be fully opened for service and maintenance.

8.4.3.4 Trash. In the vicinity of the vending machine and/or VIB areas, provide sufficient trash receptacles to segregate the different types of refuse (e.g., aluminum, plastic, paper).

8.5 BRIG.

Provide brig facilities on ships specified by BUPERS. The number of cells required is based on the number of accommodations for ships requiring brig facilities.

8.5.1 Location. Locate in an easily accessible remote area of the ship, preferably below the damage control deck but above MSD overflow heights, away from excessive noise and heat.

8.5.2 Operation. Chief-Master-at-Arms personnel operate the brig. Personnel are sent to the brig for minor infractions and generally serve 2 or 3 days.

8.5.3 Outfit and Furnishings. Brigs are outfitted with tamper-proof equipment and security type furnishings. Each cell is provided with berths and a combination jail-type stainless steel WC, lavatory, and bubbler unit. Cell doors shall possess a hand and food tray slot. The sentry is provided with a desk and controls for locking and unlocking electric operated cell doors. Brig outfitting and construction requirements are in accordance with 804-5959213.

8.5.4 Arrangement Practices. Provide an arrangement that permits the sentry direct visual access into all cells from the sentry vestibule. Detention cells shall be arranged such that the prisoners in one cell cannot observe prisoners in any other cell, where practicable. Each brig shall be provided with an emergency escape located in the cell lobby. Brig arrangement requirements shall be in accordance with 804-5959213.

8.6 POST OFFICE.

Provide a separate Post Office or mailroom facility on ships having more than 150 accommodations.

8.6.1 Location. Locate near general ship activity such as messing areas and the ship store. Avoid out-of-the-way locations due to the lower expectation of sales and increased security risk.

8.6.2 Operation. Postal personnel operate either the ship's Post Office or the mailroom.

8.6.3 Outfit and Furnishings/Arrangement Practices. The Post Office shall be arranged and outfitted with items listed in Part II, [Table 8-4](#) in accordance with 804-5959193.

Table 8-4. Post Office.

Item
One desk
One chair (see SFC No. B-3B-3 ^{1/})
One stool, Type VA
One book rack, Type "B" (see 805-1749061)
One file cabinet
Computer with LAN/WAN drop
One large safe
One small safe (only if doing finance)
Registered mail cage
One mail bag rack
One pitching case (letters)
One label rack on bulkhead (for slide labels)
High security hasp on door
View port hole in the door
Pigeon hole rack (Uline mail sorter unit, tan, model # H-4469 or equal)
Counter top
Book rack, Type "A" and "II" (see 804-5959193 and SFC No. B-6B-1) ^{1/}
Expanded metal door
Expanded metal bulkhead
Metal joiner door, Type "H" and "L" (see 804-5959320)
Passing window, Type "VSIG" (see 805-1749004)
Post office, Type A, C, D unit (see 805-2217415 and 804-5959193)
Sorting table 3' x 10' and 3'6" high
Sorting table 3' x 3' and 3'6" high
1 or 2 mailboxes in vicinity of messdecks, post office, ships store(s)
NOTE: ^{1/} SFC is the U.S. Navy Shipboard Furniture Catalog S9600-AD-GTP-010 (see http://usnhabeqptcatalog.gdit.com/).

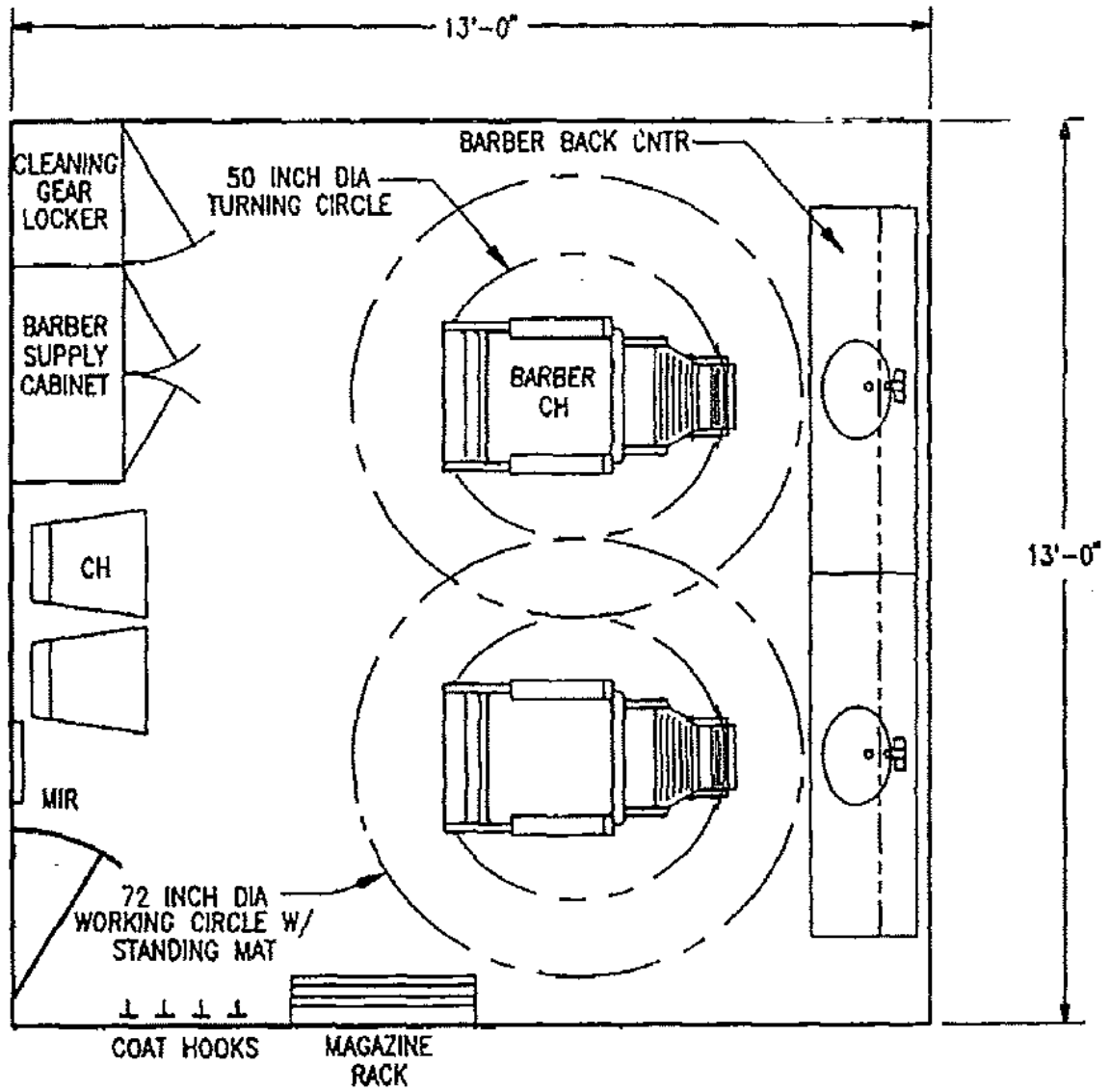

Figure 8-1. Typical Barber Shop.

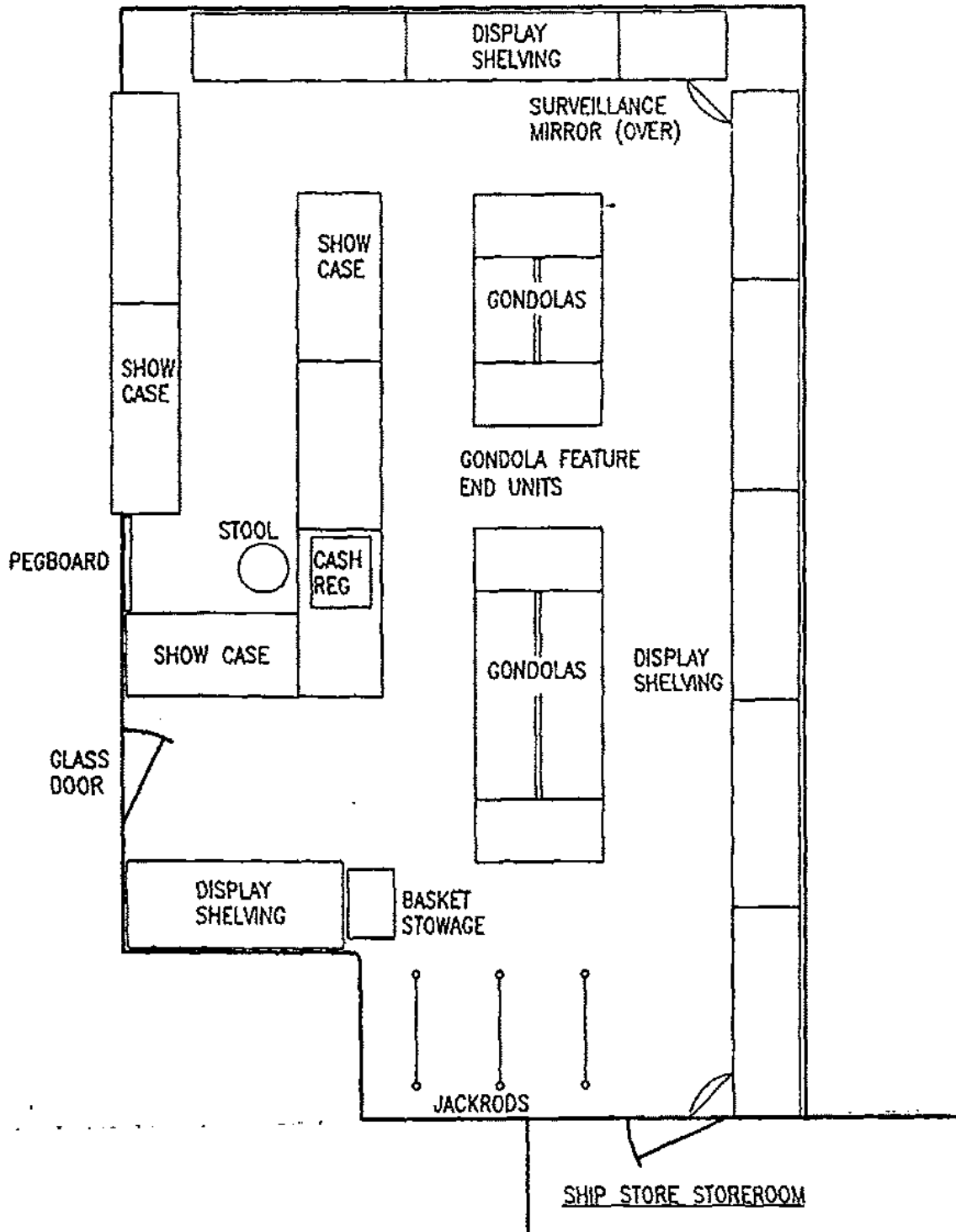

Figure 8-2. Typical Walk-In Ship Store.

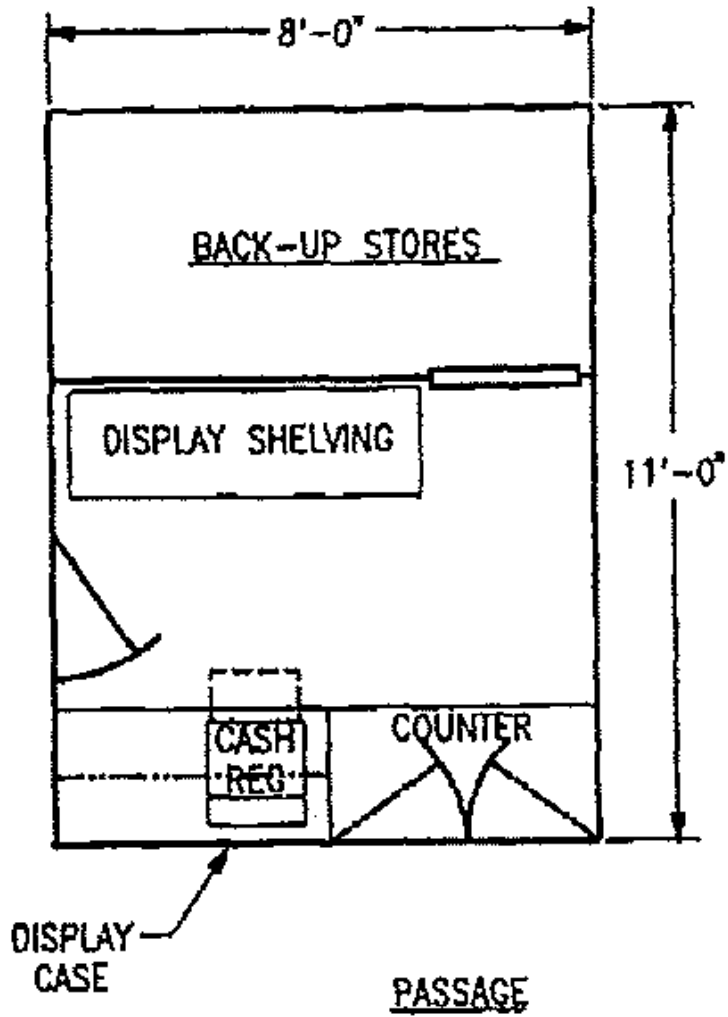

Figure 8-3. Typical Window-Service Ship Store.

CHAPTER 9 LAUNDRY AND FINISHING SPACES

9.1 GENERAL.

The space configuration, types, quantities, and arrangement of equipment in the laundry and finishing spaces are under the cognizance of NSWCPD, NAVSUP, and NEXCOM. A manned or a self-service laundry space is required for all surface ships. Laundry and finishing facilities clean, sanitize, deodorize, and restore the appearance of wool, cotton, and synthetic clothing and linens. The Navy uses upgraded, commercial and industrial laundry and finishing equipment that is modified for shipboard use. Equipment that is not modified for shipboard use is generally unsuitable due to its inability to operate for sustained periods at full capacity on a rolling and vibrating platform with frequent variations in service conditions. General purpose, utility type equipment is installed. The use of high production rate, special purpose equipment has generally been unsatisfactory in Navy ships due to the impracticality of providing requisite personnel training within the constraints of a rotating, unskilled labor pool. The objective in laundry arrangements is to permit work to flow smoothly from station to station, with minimal cross traffic, from receiving, to wash deck, to dryers/presses, to issuing. (See Part II, [Figure 9-1.](#))

9.2 SHIP'S INSTITUTIONAL FULL SERVICE LAUNDRY.

Provide ships having more than 100 accommodations with a full service laundry facility. This facility is responsible for maintaining fabrics that can be processed in aqueous cleaning solutions and subsequently dried or finish pressed with heat and pressure.

9.2.1 Location. Locate near concentrations of crew living spaces, where practicable, since 85 percent of the laundry is generated by the crew. Ensure that the location minimizes structural access cuts for washer-extractors which require dedicated shipping routes. Avoid locations with excessive ship motion and vibration in order to prolong the life of the equipment and improve operator efficiency. Service piping and ventilation considerations generally will keep laundries at the third deck or above.

9.2.2 Equipment Selection. Approved equipment is identified in U. S. Navy laundry equipment catalog S6152-B1-CAT-010 (see <http://usnhabeqptcatalog.gdit.com/>). This optimizes equipment availability and minimizes maintenance, supply support, and training needs while providing adequate service to all customers.

9.2.2.1 Laundry Equipment. In addition to large capacity washers, provide at least one small capacity unit to efficiently handle small loads such as the CO's laundry. Match washing and drying capacities as closely as possible to assure a smooth workflow. Provide a service sink or stationary tub and work table to pre-process particularly dirty clothing and for compartment cleanup.

9.2.3 Accessory Equipment. Manned laundries are generally provided with the following equipment: chair and/or stool; detergent chemical dispenser; drinking fountain; plumbed eye/face bath; hand irons and ironing boards; jack rods; laundry baskets; ready service stores; receiving and issue counters; dial-indicating scale, 100-pound capacity; soiled bag and clean bag stowage; sorting bins; spray gun; and work tables.

9.2.4 Arrangement Practices. The laundry is roughly made up of three areas: the wash area, which contains the washer-extractors, dryers, and related equipment; the press area, which contains the presses and finishing equipment; and the receiving/issue area, where clothing is checked in and out and held in temporary stowage. In large ships, these areas may be separated by bulkheads or may even be stacked on different decks; in small ships, they are generally all within one compartment. Also in large ships, arrangement concerns may dictate that the receiving and issue area be divided into separate areas.

9.2.4.1 Orientation. Orient equipment having a rotating cylinder, such as washer-extractor and tumbler dryer, so that the equipment cylinder axis is parallel to the ship's longitudinal centerline in order to minimize wear on bearings from roll of the ship.

9.2.4.2 Wash Area. Group washer-extractors and dryers together. Where practicable, arrange washer-extractors and dryers facing each other to facilitate the transfer of clothing. Orient equipment as discussed above and provide required service and maintenance clearances. Avoid locating equipment and systems in way of shipping routes. Also, avoid locating washer-extractors over fuel oil tanks, because if hotwork is needed for foundations during equipment replacement, expensive safety precautions will have to be taken within the tanks.

9.2.4.3 Coaming. Install a coaming around the washer-extractors, individually or grouped, and around service sink or stationary tub to contain spills. Ensure that the coaming does not present a tripping hazard and allows for the movement of laundry baskets.

9.2.4.4 Wash Area Accessories. Install scales at the issuing/receiving area for weighing wash loads and equalizing individual machine pocket loads. Install a plumbed eye/face bath for providing first aid to chemical injuries.

9.2.4.5 Water Heaters. Where located within the laundry, install water heaters near washer-extractors (inside the coaming) and provide them with thermal insulation to minimize heat transfer to the compartment. Size water heaters with capacity capable of supplying all washers and chemical dispensers with 120 °F water.

9.2.4.6 Dryer Side Clearance. Dryers have no side clearance requirement and may be placed adjacent to each other to minimize heat transfer to the compartment and improve drying efficiency. Dryers require access to a lint screen that is installed in the ventilation exhaust duct connected to the rear of the unit.

9.2.4.7 Utility Presses. Group utility presses in two- or three-unit sets that are conveniently arranged for use by one operator in “V” or “U” shapes, respectively. In the three-unit set, the large Class C presses make up the sides of the “U” and the Class B press is the base. Presses may be at right angles for ease in installation, but should not touch each other in order to localize vibration effects. In using a utility press set, the operator works two or three garments at once, each on a different press. The operator moves from press to press, and while one garment is pressed the operator is positioning another garment at the next press.

9.2.4.8 Spray Gun. Provide a spray gun, used to dampen garments, mounted in a rack near each utility press set, with approximately 10 feet of hose so it can reach each press buck.

9.2.4.9 Work Tables. Provide a work table for each linen press set and flatwork ironer for folding finished linens. Work tables shall be provided at utility press sets where space permits. Ensure that legs of work tables allow for laundry baskets to be stowed under the tables.

9.2.4.10 Jack Rods. Provide two-high jack rods next to each press set for holding finished garments on hangers. Space jack rods a minimum of 40 inches apart vertically, the lowest shall be 42 inches above the deck.

9.2.4.11 Receiving and Issue Area. Locate the receiving and issue area near the primary access to the space. This access should be fitted with a dutch door for passing large laundry bags in and out. Near the access provide separate stowage areas designated for soiled and clean laundry bags. Soiled and clean bag stowage areas shall be outfitted with deck grating.

9.2.4.12 Customer Service. Provide a counter in the receiving and issue area for use with laundry check-in, inspection, lot assembling, and check-out. Install a passing window over the counter for customer service. Within view of the passing window, install a scale for weighing laundry bags.

9.2.4.13 Finished Garment Stowage. Provide sorting bins in the receiving and issue area for holding assembled lots of officer and CPO clothing. Also, provide jack rods, one- and two-high, for holding coats, uniforms, and other articles of clothing that are hung rather than folded.

9.2.4.14 Drinking Fountain. Provide a drinking fountain in a readily accessible, central location.

9.2.4.15 Laundry Basket Clearance. Passages within the laundry should permit ready movement of both skid and caster type, standard, laundry baskets.

9.2.4.16 Ready Service Stores. Provide stowage within the laundry for as much ready service stores as practicable.

9.3 SELF-SERVICE LAUNDRY.

All ships shall be provided with self-service laundry facilities.

9.3.1 Location. Locate near user living spaces. In order to ensure the safety and cleanliness and to maintain the reliability of equipment, all self-service laundries are supervised by the assigned responsible department.

9.3.2 Equipment Selection. Select equipment as required, in coordination with NEXCOM.

9.3.3 Arrangement Practices. Most arrangement practices for full service laundries apply to self-service laundries. If space permits, provide a waiting area with chairs.

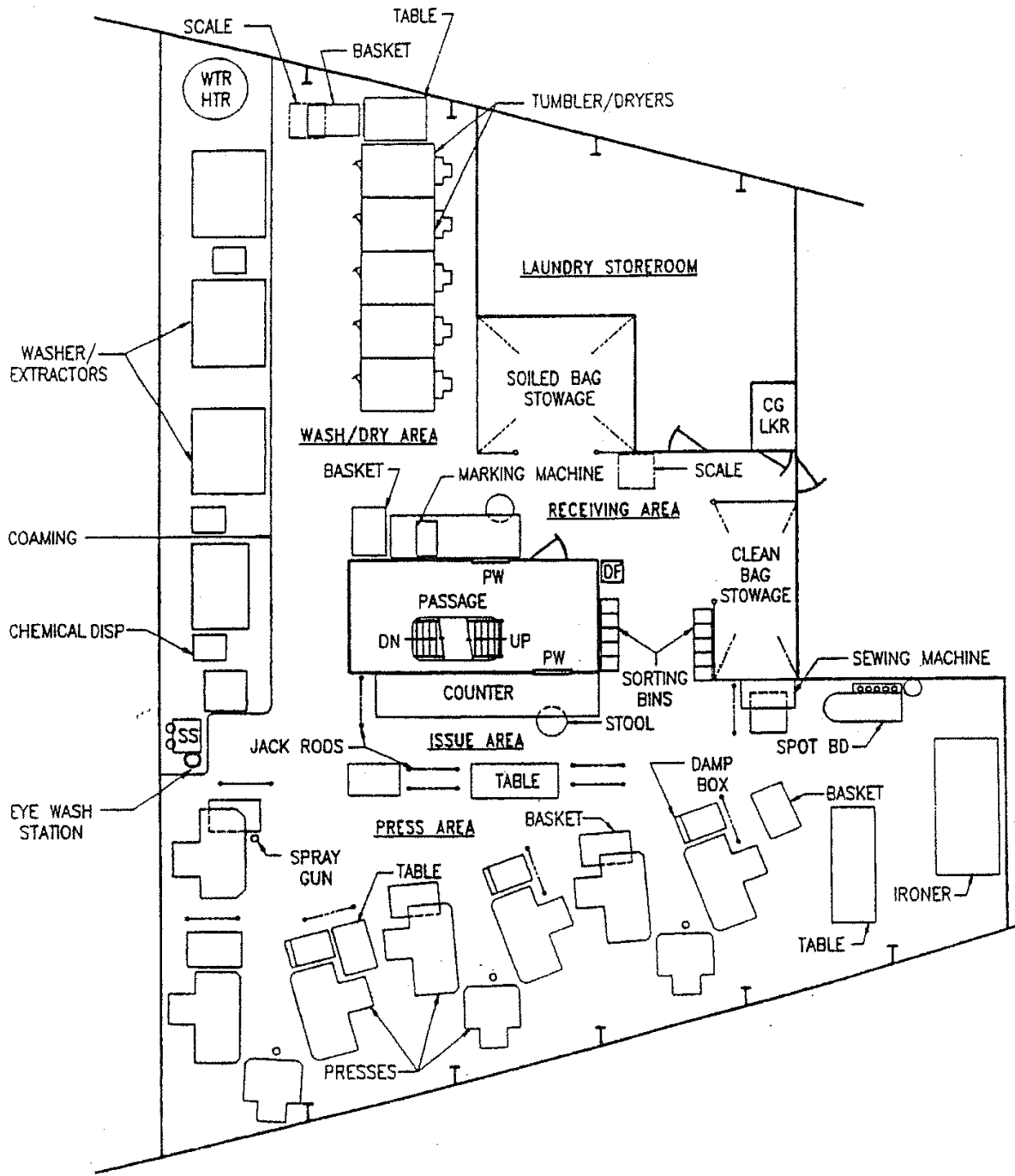

Figure 9-1. Typical Laundry.

APPENDIX A APPLICABLE DOCUMENTS

A.1 GENERAL.

The documents listed in this section are specified in Parts I and II of this publication. While every effort has been made to ensure the completeness of this list, document users are cautioned that they must meet all specified requirements of documents cited in Parts I and II of this publication, whether or not they are listed.

A.2 GOVERNMENT DOCUMENTS.

A.2.1 Specifications, Standards, and Handbooks. The following specifications, standards, and handbooks form a part of this document to the extent specified herein. Unless otherwise specified, the issues of these documents are those cited in the solicitation or contract.

FEDERAL SPECIFICATIONS

- | | | |
|----------|---|-------------------------------------------------------------------------------------------------|
| RR-C-901 | - | Cylinders, Compressed Gas: Seamless Shatterproof, High Pressure DOT 3AA Steel, and 3AL Aluminum |
|----------|---|-------------------------------------------------------------------------------------------------|

FEDERAL STANDARDS

- | | | |
|-------------|---|---------------------------------------|
| FED-STD-595 | - | Colors Used in Government Procurement |
|-------------|---|---------------------------------------|

DEPARTMENT OF DEFENSE SPECIFICATIONS

- | | | |
|---------------|---|------------------------------------------------------------------------------------------------|
| MIL-S-901 | - | Shock Tests, H.I. (High-Impact) Shipboard Machinery, Equipment, and Systems, Requirements for |
| MIL-DTL-16377 | - | Fixtures, Lighting; and Associated Parts; Shipboard Use, General Specification for |
| MIL-P-17171 | - | Plastic, Laminate, Decorative, High Pressure |
| MIL-PRF-20092 | - | Rubber or Plastic Sheets and Assembled and Molded Shapes, Synthetic, Foam or Sponge, Open Cell |
| MIL-DTL-24607 | - | Enamel, Interior, Nonflaming (Dry), Chlorinated Alkyd Resin, Semigloss |
| MIL-PRF-24712 | - | Coatings, Powder, Thermosetting |
| MIL-PRF-32038 | - | Shipboard Furniture, Fixtures, Fittings, and Accessories |

DEPARTMENT OF DEFENSE STANDARDS

- | | | |
|---------------|---|-------------------------------------------------------------------------------------------------------------------------------|
| MIL-STD-167-1 | - | Mechanical Vibrations of Shipboard Equipment (Type I – Environmental and Type II – Internally Excited) |
| MIL-STD-461 | - | Requirements for the Control of Electromagnetic Interference Characteristics of Subsystems and Equipment |
| MIL-STD-1472 | - | Human Engineering |
| MIL-STD-1474 | - | Noise Limits |
| MIL-STD-1623 | - | Fire Performance Requirements and Approved Specifications for Interior Finish Materials and Furnishings (Naval Shipboard Use) |

DEPARTMENT OF DEFENSE HANDBOOKS

- | | | |
|--------------|---|----------------------------------|
| DOD-HDBK-289 | - | Lighting on Naval Ships (Metric) |
|--------------|---|----------------------------------|

T9640-AC-DSP-010/HAB, Rev 1

MIL-HDBK-2189/672-1 - Design Methods for Naval Shipboard Systems Section 672-1 Calculation of Storeroom Capacities

DEPARTMENT OF DEFENSE DATA ITEM DESCRIPTIONS (DIDS)

DI-MISC-81123 - Color Coordination Manual(s) for Habitability Spaces

(Copies of these documents are available online at <http://quicksearch.dla.mil/>.)

A.2.2 Other Government Documents, Drawings, and Publications. The following other Government documents, drawings, and publications form a part of this document to the extent specified herein.

BUREAU OF MEDICINE AND SURGERY (BUMED)

BUMEDINST 6230.15 - Immunizations and Chemoprophylaxis for the Prevention of Infectious Diseases

BUMEDINST 6260.30 - Mercury Control Program for Dental Treatment Spaces

NAVMED P-5010-2 - Manual of Naval Preventive Medicine, Chapter 2, Sanitation of Living Spaces and Related Service Facilities

NAVMED P-5010-6 - Manual of Naval Preventive Medicine, Chapter 6, Water Supply Afloat

TB MED 530/NAVMED P-5010-1/ AFMAN 48-147_IP - Tri-Service Food Code

(Copies of these documents are available online at <http://www.med.navy.mil/>.)

CENTERS FOR DISEASE CONTROL AND PREVENTION

CDC Vaccine Storage and Handling Toolkit

(Copies of this document are available online at <http://www.cdc.gov/vaccines/hcp/admin/storage/toolkit/>.)

MILITARY SEALIFT COMMAND INSTRUCTIONS

COMSCINST 9330.6 - Accommodations Standards for Military Sealift Command Ships

(Copies of this document are available online at <http://www.msc.navy.mil/instructions/>.)

NAVAL SEA SYSTEMS COMMAND (NAVSEA) DRAWINGS

593-7556875 - Food Waste Disposers Interface Drawing

804-1634565 - Benches, Padded, with Stowage Under for Submarine Use

804-1648663 - Locker, Cleaning Gear Stowage

804-4661744 - Chair, Barber, Lightweight – Shipboard Type

804-5000991 - Sheathing Systems, Details for Bulkheads Sheathing on Surface Ships

804-5000994 - Sheathing System, Details for Overhead Sheathing on Surface Ships

804-5959193 - Typical Arrangements, Post Office

804-5959213 - Ships Brig, Typical Arrangement

804-5959320 - Doors, Joiner, Metal

804-6983470 - Stand, Beverage, Service, Food Service Spaces

- 804-6983471 - Dresser, Typ, & Misc Dets, Food Service Spaces
- 804-6983509 - Station, Collective Protection System Casualty Decontamination, Arrangement and Details
- 804-6983514 - Sanitary Spaces, Navy Surface Ship, Arrangements and Details
- 805-1629991 - Supply Locker for Barber Shop
- 805-1631454 - Bread, Pie and Cake Stowage (Arrangement)
- 805-1641006 - Hospital Berth
- 805-1749004 - Metal Joiner Passing Windows, Assemblies & Details
- 805-1749061 - Bookracks, Types A, B & C
- 805-2217415 - Post Office, Type "A" & "D" Units
- 805-2253565 - Thaw Rack Details and Typical Arrangements
- 805-2253566 - Thaw Rack Details
- 805-2253852 - Mirror, Mounted, Shock Hardened
- S3304-860200 - Magazine Rack, Type A & B
- S3702-921917 - First Aid Box, Aluminum

(Copies of these documents are available from the applicable repositories listed in S0005-AE-PRO-010/EDM, which can be obtained online via Technical Data Management Information System (TDMIS) at <https://mercury.tdmis.navy.mil/>. Copies of these documents may also be obtained from the Naval Ships Engineering Drawing Repository (NSED) online at <https://199.208.213.105/webjedmics/index.jsp>. To request an NSED account for drawing access, send an email to NNSY_JEDMICS_NSED_HELP_DESK@navy.mil.)

NAVAL SEA SYSTEMS COMMAND (NAVSEA) INSTRUCTIONS

- NAVSEAINST 9210.4 - Changes, Repair & Maintenance to Nuclear Powered Ships

(Copies of this document are available from Commander, Naval Sea Systems Command, ATTN: SEA 08J, 1333 Isaac Hull Avenue, SE, Stop 5160, Washington Navy Yard, DC 20376-5160 or by email request to commandstandards@navy.mil.)

NAVAL SEA SYSTEMS COMMAND (NAVSEA) PUBLICATIONS

- 0938-LP-018-0010 - Heating, Ventilation, and Air Conditioning Design Criteria for Surface Ships of the United States Navy
- S6152-B1-CAT-010 - Shipboard Laundry and Dry Cleaning; Equipment Catalog
- S6161-Q5-CAT-010 - Naval Shipboard Food Service Equipment Catalog
- S6163-EG-FSE-010 - Installation, Operation Instructions and Schematics for Soda-Apollo, Vending in a Box (VIB)
- S9086-QH-STM-010/470 - NSTM Chapter 470, Shipboard BW/CW Defense and Countermeasures
- S9086-V4-STM-010/655 - NSTM Chapter 655, Laundry and Dry Cleaning
- S9593-C6-IIN-010 - Shipboard Solid Waste Processing Equipment, Basic Ship Installation Integration Package; Installation Instruction
- S9600-AD-GTP-010 - U.S. Navy Shipboard Furniture Catalog

T9640-AC-DSP-010/HAB, Rev 1

- T9070-AB-PRO-010 - NAVSEA Design Practices and Criteria Manual for General Arrangement Design
- T9070-AL-DPC-020/077-2 - NAVSEA Hazardous Material Avoidance Process; NAVSEA Technical Publication

(Copies of these documents are available online via Technical Data Management Information System (TDMIS) at <https://mercury.tdmis.navy.mil/> by searching for the document number without the suffix. Refer questions, inquiries, or problems to: DSN 296-0669, Commercial (805) 228-0669. These documents are available for ordering (hard copy) via the Naval Logistics Library at <https://nll.ahf.nmci.navy.mil/>. For questions regarding the NLL, contact the NLL Customer Service at nllhelpdesk@navy.mil, (866) 817-3130, or (215) 697-2626/DSN 442-2626. The U.S. Navy Shipboard Furniture and Equipment Catalogs are available at <http://usnhabeqptcatalog.gdit.com/>.)

NAVAL SEA SYSTEMS COMMAND (NAVSEA) PUBLICATIONS

- SDS 077-1 - Safety Design Criteria for Stowage Areas Containing Hazardous Materials on Surface Ships

(Copies of this document are available from Commander, Naval Sea Systems Command, ATTN: SEA 05P5, 1333 Isaac Hull Ave. SE Stop 5145, Washington Navy Yard, DC 20376-5145 or by email request to commandstandards@navy.mil.)

NAVAL SEA SYSTEMS COMMAND (NAVSEA) STANDARD ITEMS

- NAVSEA Standard Item 009-26 - Deck Covering Requirements; accomplish

(Copies of this document are available online at <http://www.navsea.navy.mil/Home/RMC/CNRM/OurPrograms/SSRAC/NSI.aspx>.)

NAVAL SUPPLY SYSTEMS COMMAND

- NAVSUP P-487 - Ship's Store Afloat

(Copies of this document are available online at <https://nll.ahf.nmci.navy.mil/>.)

NAVAL SURFACE FORCES COMMAND INSTRUCTIONS

- COMNAVSURFPAC/COMNAVSURFLANT INSTRUCTION 6000.1 - Shipboard Medical Department Procedures Manual

(Copies of this document are available online at <http://www.public.navy.mil/surfor>.)

NAVAL WARFARE PUBLICATIONS

- NTTP 4-01.4 - Underway Replenishment

(Copies of this document are available online at <https://ndls.nwdc.navy.mil/>.)

OPERATIONAL NAVY (OPNAV) INSTRUCTIONS

- OPNAVINST 4442.1 - Stowage Space Requirements for New Construction and Major Conversions of Ships
- OPNAVINST 5100.19 - Naval Safety and Occupational Health (SOH) Program for Forces Afloat
- OPNAVINST 6110.1 - Physical Readiness Program
- OPNAVINST 9640.1 - Shipboard Habitability Program

(Copies of these documents are available online at <http://doni.documentservices.dla.mil/default.aspx>.)

A.3 NON-GOVERNMENT PUBLICATIONS.

The following documents form a part of this document to the extent specified herein. Unless otherwise specified, the issues of these documents are those cited in the solicitation or contract.

ASTM INTERNATIONAL

- ASTM A240/A240M - Standard Specification for Chromium and Chromium-Nickel Stainless Steel Plate, Sheet, and Strip for Pressure Vessels and for General Applications
- ASTM B127 - Standard Specification for Nickel-Copper Alloy (UNS N04400) Plate, Sheet, and Strip
- ASTM B209 - Standard Specification for Aluminum and Aluminum-Alloy Sheet and Plate
- ASTM C1036 - Standard Specification for Flat Glass

(Copies of these documents are available online at www.astm.org.)

INTERNATIONAL ORGANIZATION FOR STANDARDIZATION (ISO)

- ISO 2631-1 - Mechanical Vibration and Shock -- Evaluation of Human Exposure to Whole-body Vibration -- Part 1: General Requirements
- ISO 2923 - Acoustics -- Measurement of Noise on Board Vessels
- ISO 6954 - Mechanical Vibration -- Guidelines for the Measurement, Reporting and Evaluation of Vibration with Regard to Habitability on Passenger and Merchant Ships

(Copies of these documents are available online at www.iso.org.)

SAE INTERNATIONAL

- ANSI/SAE Z26.1 - Safety Glazing Materials for Glazing Motor Vehicles and Motor Vehicle Equipment Operating on Land Highways – Safety Standard

(Copies of this document are available online at www.sae.org.)

SOCIETY OF NAVAL ARCHITECTS AND MARINE ENGINEERS (SNAME)

- SNAME Technical and Research Bulletin 3-37 - Design Guide for Shipboard Airborne Noise Control

(Copies of this document are available online at <http://www.sname.org>.)

APPENDIX B DEFINITIONS

B.1 ACCOMMODATIONS.

The number of personnel permanently supported in a given ship by habitability spaces, systems, fixtures, and equipment. Accommodations are provided for ship's company plus any of the following embarked personnel: troops, air wings, staff, detachments, short-term assignments, indoctrination personnel, civilian technical representatives, and official visitors or guests. Accommodations for some personnel can be categorized as surge or transient depending on their function.

B.2 CHIEF PETTY OFFICER (CPO)/SENIOR NONCOMMISSIONED OFFICER (SNCO).

Refers to E7-E9 personnel.

B.3 CREW/TROOP.

Refers to E1-E6 personnel.

B.4 ENLISTED PERSONNEL.

Refers to CPO/SNCO and crew/troop.

B.5 EXISTING SHIPS.

Ships that do not meet the new ship designs definition, in addition to those accepted and commissioned.

B.6 LIGHT-TIGHT.

Bulkheads, for the purposes of this document, are non-tight bulkheads with no visible openings in the structure.

B.7 NAVY STANDARD CORE MENU (NSCM).

The NSCM is based upon a 21-day cycle that includes a different breakfast, lunch, and dinner menu for each day of the cycle. Special theme meals are incorporated into the cycle, allowing for holiday and ethnic cuisine to be served and to allow flexibility for Sailors to plan "steel beach picnics," ice cream socials, and other similar events. The NSCM is prepared and updated by TYCOM. NAVSUP should be contacted for further details on food service equipment needed to support the NSCM.

B.8 NEW SHIP DESIGNS.

Ship designs sufficiently early in the design process when changes can reasonably be made to the Capability Development Document (CDD) (or the Initial Capabilities Document [ICD]), or which have not completed preliminary design.

B.9 SHIPS COMPANY.

All Officer, CPO, and crew personnel assigned to the ship.

B.10 SURGE.

Personnel embarked for short durations for special operations, exercises, or mobilizations. Surge personnel accommodations require provision for a berth only. When unqualified reference to troops is made herein, it excludes surge troops.

B.11 TRANSIENTS.

Personnel embarked for short durations who do not contribute to the host ship operational capability. Transients normally are waiting for transfer to, or arrival at, another destination. Ships receiving a steady influx of transients require support for them so that habitability for permanently assigned personnel is not degraded.

NAVSEA/SPAWAR TECHNICAL MANUAL DEFICIENCY/EVALUATION REPORT (TMDER)

INSTRUCTIONS: Continue on 8 ½" x 11" on page if additional space is needed.

1. Use this report to indicate deficiencies, problems and recommendations relating to publications.
2. For **CLASSIFIED** TMDERs see OPNAVINST 5510H for mailing requirements.
3. For TMDERs that affect more than one publication, submit a separate TMDER for each.
4. Submit TMDERs at web site <https://nsdsa.nmci.navy.mil> or mail to: **COMMANDER, CODE 310 TMDERs, NAVSURFWARCENDIV NSDSA, 4363 MISSILE WAY BLDG 1389, PORT HUENEME CA 93043-4307**

1. PUBLICATION NUMBER	2. VOL/PART	3. REV/DATE OR CHG/DATE	4. SYSTEM/EQUIPMENT ID
5. TITLE OF PUBLICATION			6. REPORT CONTROL NUMBER (6 digit UIC-YY-any four: xxxxxx-10-xxxx)

7. RECOMMEND CHANGES TO PUBLICATION

7a. Page #	7b. Para #	7c. RECOMMENDED CHANGES AND REASONS

8. ORIGINATOR'S NAME AND WORK CENTER	9. DATE	10. ORIGINATOR'S E-MAIL ADDRESS	11. TMMA of Manual (NSDSA will complete)
12. SHIP OR ACTIVITY Name and Address (Include UIC/CAGE/HULL)		13. Phone Numbers: Commercial () ___-____ DSN ___-____ FAX () ___-____	

FOLD HERE AND TAPE SECURELY
PLEASE DO NOT STAPLE

INCLUDE COMPLETE ADDRESS

USE
PROPER
POSTAGE

FOR OFFICIAL USE ONLY

**COMMANDER
CODE 310 TMDERs
NAVSURFWARCENDIV NSDSA
4363 MISSILE WAY BLDG 1389
PORT HUENEME CA 93043-4307**

FOLD HERE AND TAPE SECURELY
PLEASE DO NOT STAPLE